



**OPERATING AND PARTS MANUAL**  
*DLQ & DLQHD LIQUID APPLICATORS*

2019





# TABLE OF CONTENTS

TO YOU THE OWNER.....	1
LIMITED WARRANTY STATEMENT.....	2
NEW MACHINE CHECKOUT.....	3
IMPLEMENT SAFETY.....	4
PRE-SEASON CHECK.....	5
BOLT TORQUE CHART.....	6
LOADED RADIUS OF VARIOUS TIRES.....	7
LIQUID INJECTOR NOZZLE CHART.....	8
GPA TABLE.....	9
DLQ TONGUE - JACK AND HITCH OPTIONS.....	11
DLQ TOOLBAR CONTROL ARM.....	12
DLQSTD AXLE, SPINDLE, AND HUB.....	13
1002194, 819 8-BOLT HUB ASSEMBLY, COMPLETE.....	14
DLQHD AXLE, SPINDLE, AND HUB.....	15
4410248, 873 10-BOLT HUB ASSEMBLY, COMPLETE.....	16
DLQHD 2000 AXLE, SPINDLE, AND HUB.....	17
4410337, 881 10-BOLT HUB ASSEMBLY, COMPLETE.....	18
DLQ ADJUSTABLE AXLE.....	19
4410449, 891 10-BOLT HUB ASSEMBLY, COMPLETE.....	20
DLQ SINGLE FOLD TOOLBAR.....	21
DLQ FRONT FOLD TOOLBAR.....	22
DLQ DOUBLE FOLD TOOLBAR.....	23
DLQHD 60' TOOLBAR.....	24
TOOLBAR CYLINDER STOP.....	25
DLQ LIGHT KIT.....	26
CYLINDER LINKAGE AND DOWNPRESSURE.....	27
DLQ WING LOCK.....	28
2 PIN GAUGE WHEEL AND BRACKET.....	29
4410086, 888 6-BOLT HUB ASSEMBLY, COMPLETE.....	30
GROUND DRIVE ASSEMBLY.....	31
DLQ 3-SHUTOFF RAVEN PLUMBING.....	32
YETTER COULTER ASSEMBLY.....	33
NOZZLE AND COULTER ASSEMBLY.....	34
GROVE COULTER ASSEMBLY.....	35
GROVE KNIFE AND INJECTION.....	36
DLQ DOWNPRESSURE KIT - GULL WING PLUMBING.....	37
DECAL LAYOUT.....	38
PARTS ORDERING PROCEDURE.....	39

## TO YOU, THE OWNER

Your Dalton Ag Equipment is the most modern, up-to-date, versatile, machine available for fertilizer application. The machine is the result of many years of experience, research, development and testing of equipment for fertilizer application. It is soundly engineered and carefully built to rigid specifications. It is of rugged and simple construction, with a minimum of moving parts.

However, to obtain maximum performance from your Dalton Ag Equipment, it is necessary to follow the instructions and safety suggestions in this manual. Each section has been carefully prepared for the purpose of providing needed and valuable information to the owner and operator. Each operator of this unit should be familiar with the contents of this manual. Keep it in a safe and convenient location. THERE ARE MANY SAFETY SUGGESTIONS (CAUTION AREAS) PRINTED THROUGHOUT THIS MANUAL. CAREFULLY READ THEM ALL BEFORE OPERATING THIS UNIT.

## DESIGN IMPROVEMENTS

Dalton Ag Products follows a policy of continuous products improvement. We therefore reserve the right to make design improvements, and changes in specifications and prices, without incurring obligations to make revisions or additions to equipment previously sold.

**REGISTER  
WARRANTY  
ONE OF  
FOUR WAYS**

- Register on-line at:  
[www.daltonag.com](http://www.daltonag.com)
- Fax your completed warranty registration form to:  
641-333-4429
- Email your completed warranty registration form to:  
[office@daltonag.com](mailto:office@daltonag.com)
- Mail your completed warranty registration form to:  
Dalton Ag, Inc.  
P.O. Box 70  
Lenox, IA 50851



## LIMITED WARRANTY STATEMENT

DALTON AG, INC. warrants to the original purchaser only that all products manufactured under the Dalton Ag and Mobility Brands will be free from defects in material and workmanship under normal use and service.

DALTON AG's obligation under this warranty is limited to repairing or replacing, as it may elect, free of charge and without charge for installation, at the place of business of a dealer or distributor authorized to handle the equipment covered by this warranty or at a DALTON AG facility, any parts that prove, in DALTON AG's judgment, to be defective in material or workmanship within two (2) years after delivery to the original purchaser. DALTON AG shall not be liable for personal injuries or any special or consequential damages of any kind, either direct or indirect. This warranty is subject to acts of God, fire and existing conditions of supply and demand, production, ability or inability to deliver, or for any other valid reason beyond the reasonable control of DALTON AG. No distributor, dealer, agent or DALTON AG employee (other than DALTON's President in writing) is authorized to extend or make any other or further express or implied warranty or incur any additional obligation on DALTON AG's behalf in connection with the sale of this product.

### Customer Responsibility

**Product Registration** - It is a condition of this warranty that the original purchaser fill out the warranty card furnished by DALTON AG and return it to DALTON AG to be recorded in DALTON AG's owner file. Registration may also be done on line at [www.DaltonAg.com/warrantyregistration](http://www.DaltonAg.com/warrantyregistration). If the original purchaser's card or electronic registration is not on file at DALTON AG's office, the warranty period will extend only from date equipment was picked up or shipped from the DALTON AG plant.

**Maintenance** - It is the customer's responsibility to maintain their equipment in accordance with the instructions provided in the Operator's Manual. DALTON AG recommends that you keep records and receipts as the customer may be required to verify the maintenance instructions have been followed.

**Operation** - It is the customer's responsibility to operate the equipment only for the purpose for which it was designed and in accordance with all safety and operational recommendations contained in the Operator's Manual. If a defect in materials or workmanship occurs, it is the customer's responsibility to cease operating the equipment until authorized repairs are made. Damage incurred from continued operation after a defect is discovered may not be covered by this warranty.

### What this Warranty Covers

This warranty covers failures caused by defects in materials or workmanship only.

This Warranty does not cover failures caused by:

- Improper operation
- Natural calamities
- Unauthorized modifications
- Unauthorized repairs
- Use of Non DALTON AG parts
- Neglected maintenance
- Usage contrary to the intended purpose of the product

This Warranty does not cover replacement of Wear or Maintenance Items including, but not limited to:

- Lubricants
- Filters
- Hoses
- Tires
- Disks
- Chains
- Idlers
- Blades
- Belts
- Bearings

This Warranty does not cover:

- Pickup and delivery of the equipment
- Service Calls or Travel Time to and from sites
- Rental of replacement equipment during repair period
- Products that have been declared a total loss and subsequently salvaged
- Overtime labor charges

### Parts Warranty

DALTON AG warrants its replacement parts against defects in materials or workmanship for a period of 90 days or the remainder of the product warranty, whichever is longer under the terms set out above. Remedy for defective replacement parts for units that are beyond the original product warranty, will be limited to replacement of the failed part.

**DaltonAg.com**

602 E. Van Buren Lenoir, Iowa 50851  
100% Employee Owned

**PHONE: 800.342.7498**  
**FAX: 641.333.4429**

## NEW MACHINE CHECKOUT

1. All hardware properly tightened.
2. Lubrication of grease fittings.
3. Wheel bolts tightened to proper specs.
4. Check hydraulic hoses and fittings.

## MAINTENANCE

1. Visually inspect machine daily.
2. Repair or replace any worn or damaged parts.

## LUBRICATION SCHEDULE

Careful observance of the following lubrication schedule is the best preventative maintenance program for your Dalton Ag Equipment. We recommend that you establish a firm program to insure lubrication in strict compliance with the following schedule. Use only good grade pressure gun type grease unless otherwise specified.

### Daily Lubrication

Hinge points

### Weekly Lubrication

Wheel bearings  
Coulters

### Annual Lubrication

Check all bearings - repack or replace as needed

## IMPLEMENT SAFETY

In addition to design and configuration of equipment, safety and accident prevention are dependent upon the awareness, concern, and proper training of personnel involved in the operation, transport, maintenance, and storage of equipment. Failing to follow these safety messages can result in machine damage, personal injury, and/or death.

- Before operating your applicator, thoroughly read and understand your operator's manual. If you do not understand any portion of the operator's manual, contact your local Dalton Ag dealer immediately for clarification.
- Furnish this manual to a new operator.
- Tow with tractor only. Never transport applicator unit in excess of 20 MPH. Maintain a safe speed.
- Use a Slow-Moving-Vehicle (SMV) emblem when transporting.
- Be sure safety decals are readable. All safety related decals must be replaced if the applicator is painted or the decals are otherwise rendered unreadable.
- Install transport link before transporting.
- Always check for overhead obstacles in transporting applicator and before folding or unfolding the wings of the unit.
- Never permit riders on the applicator or tractor.
- Proceed slowly on rough or slippery roadways, on side hills, and around curves to avoid tipping.
- Reduce speed when approaching ditches and corners. Do not make sharp turns with brakes.
- Machinery should be operated only by persons familiar to the tractor, applicator unit, and the safety related items.
- Do not stand on, or straddle tongue when unhitching.
- Do not modify or permit anyone to modify this applicator and any of its components without first consulting your Dalton Ag dealer.
- Do not lubricate, adjust, or repair when applicator unit is in motion.
- Use only approved replacement parts.
- To prevent serious injury from high pressure fluid, NEVER attempt to inspect, service, or disassemble any part of the hydraulic system until all pressure is relieved by lowering the toolbar to the ground (or secure with cylinder transport stops provided).
- High-pressure fluid is nearly invisible but has enough force to penetrate the skin. Never use the hands to search out a suspected leak. If injured by escaping fluid, obtain medical attention at once to minimize chance of infection. Wear safety glasses or goggles to avoid eye injury when working on the hydraulic system.
- Always check torque on wheel bolts before transporting.

## **PRE-SEASON CHECK**

1. Carefully review the safety suggestions in this manual.
2. Check all bolts for proper tightness. When the implement is new, check after one hour and every few hours of operation.
3. Replace ground tools that are severely worn, broken or damaged.
4. Check tires for proper inflation. All tires should be inflated equally to avoid side draft.
5. Check the wheel lug bolts daily, keep wheel bolts tight.
6. Grease all fittings.
7. Inspect, repack, or replace (if necessary) wheel bearings and seals.
8. Check hoses, hose routing and hydraulic cylinders. Any indication of leakage or fraying of hoses should be corrected.

## **OFF-SEASON STORAGE**





Following these suggestions will extend service life and satisfaction:

1. A little time and effort spent cleaning your machine before storing will repay in longer service, easier operation and higher resale value.
2. Inspect for worn or damaged parts. Replace, if required, and avoid delays the next season.
3. Repaint all areas where the original paint is worn off.
4. Lubricate your implement.
5. Grease all exposed metal surfaces of ground tools.
6. Store the unit inside a shed to protect from weather and on a level area with wings down. The ground working parts should rest on boards.
7. Disconnect the rod end of the lift cylinders and retract the rod into the cylinder to prevent the cylinder rod from rusting.
8. Cap or plug all hydraulic oil lines, if the cylinders are removed. This is to prevent any contaminants from entering the hydraulic system.
9. Raise tires off ground or remove and store in cool dry location out of sunlight.



**IMPORTANT :** Over tightening hardware can be as damaging as under tightening. Tightening beyond recommended torque will reduce the fastener's shock load capacity.

## BOLT TORQUE CHART

SIZE							
	SAE GRADE 2		SAE GRADE 5		SAE GRADE 8		L9
	ASSEMBLY TORQUE DRY	LUBRICATED	ASSEMBLY TORQUE DRY	LUBRICATED	ASSEMBLY TORQUE DRY	LUBRICATED	ASSEMBLY TORQUE LUBRICATED
1/4-20	66*	49*	8	75*	12	9	11
1/4-28	76*	56*	10	86*	14	10	13
5/16-18	11	8	17	13	20	18	21
5/16-24	12	9	19	14	25	20	23
3/8-16	20	15	30	23	45	30	33
3/8-24	23	17	35	25	50	35	38
7/16-14	30	24	50	35	70	55	60
7/16-20	35	25	55	40	80	60	65
1/2-13	50	35	75	55	110	80	95
1/2-20	55	40	90	65	120	90	105
9/16-12	65	50	110	80	150	110	140
9/16-18	75	55	120	90	170	130	150
5/8-11	90	70	150	110	220	170	185
5/8-18	100	80	180	130	240	180	205
3/4-10	160	120	260	200	380	280	290
3/4-16	180	140	300	220	420	320	355
7/8-9	190	140	400	300	600	460	505
7/8-14	210	155	440	320	660	500	585
1-8	220	160	580	440	900	680	775
1-14	240	170	640	480	1000	740	900
1 1/8-7	300	220	800	600	1280	960	1150
1 1/8-12	340	260	880	660	1440	1080	1325
1 1/4-7	420	320	1120	840	1820	1360	1600
1 1/4-12	460	360	1240	920	2000	1500	1750
1 3/8-6	560	420	1460	1100	2380	1780	---
1 3/8-12	640	460	1680	1260	2720	2040	---
1 1/2-6	740	560	1940	1460	3160	2360	3250
1 1/2-12	840	620	2200	1640	3560	2660	3650

**ITEMS WITH \* = INCH POUNDS  
ALL OTHERS = FOOT POUNDS**

**WARNING:** Never work around any raised implement while in the raised position without using safety lockups.

**LOADED RADIUS OF VARIOUS TIRES -  
FOR USE IN SETTING JOHN BLUE  
GROUND-DRIVEN PUMPS**

<b>TIRE SIZE</b>	<b>LOADED RADIUS</b>	<b>TIRE SIZE</b>	<b>LOADED RADIUS</b>
6.70-15SL	12.9	9.00-20	19.0
7.60-15SL	13.4	10.0-20	19.6
9.5L-15SL	13.6	11.0-20	20.1
10.0-15SL	15.1	12.0-20	20.6
11L-15SL	13.5	15.0-22.5	20.0
12.5L-15SL	14.5		
9.00-16SL	14.7		
11L-16SL	13.9		
12.5L-16SL	15.0		
13.5L-16.1SL	17.5		
16.5L-16.1SL	17.3		
4.8-8	7.5		
18-9.5	7.8		
16 X 6.50-8	7.4		

## LIQUID INJECTOR NOZZLE CHART

### NOZZLE SELECTION

1. To select the proper nozzle size, first determine the gallons per acre and speed that is going to be used. Go to the table for the proper row spacing.
2. Find the speed across the top, go down to the "Gallon Per Acre" and read the nozzle size in the box.
3. Order nozzle by m.p.h. and gallons per acre.

### FORMULA TO CONVERT POUNDS PER ACRE TO GALLONS PER ACRE

Pounds per Acre/Percent of Nitrogen = Total Pounds per Acre/pounds per Gallon = Gallons per Acre

EXAMPLE: 100 (# per Acre) / .28 (28%) = 357 (# per Acre) / 10.65 (#per Gallon) = 33.5 (GPA)

NOTE: If 1/2 rate is needed on outside shanks, order two nozzles with half the capacity. If 1 1/2 rate is needed on outside shanks, order two nozzles with 1 1/2 times the capacity.

**\*\*\*REFER TO THE FOLLOWING RATE CHART FOR TIPS AND APPLICATION\*\*\***

## GPA 30" SPACING

gallons per acre x 1.15 = water per acre

TIP NUMBER	ORIFICE DIAM.	PSI	CAP .1 NOZZLE GPM	5 MPH GPA	6 MPH GPA	7 MPH GPA	8 MPH GPA	9 MPH GPA	10 MPH GPA
TP0004	.055	20	.28	11	9	8	7		6
H1/4U-SS0004		30	.35	14	12	10	9	8	7
		40	.40	16	13	11	10	9	8
		50	.45	18	15	13	11	10	9
		60	.49	19	16	14	12	11	10
TP0005	.061	20	.35	14	12	10	9		
H1/4U-SS0005		30	.43	17	14	12	11	9	8
		40	.50	20	16	14	12	11	10
		50	.56	22	18	16	14	12	11
		60	.61	24	20	17	15	13	12
TP0006	.067	20	.42	17	14	12	10	9	8
H1/4U-SS0006		30	.52	20	17	15	13	11	10
		40	.60	24	20	17	15	13	12
		50	.67	26	22	18	17	15	13
		60	.73	28	24	20	18	16	15
TP0008	.078	20	.57	23	19	16	14	13	11
H1/SS0008		30	.69	27	22	19	17	15	13
		40	.80	32	26	22	20	17	16
		50	.89	53	29	25	22	19	17
		60	.98		32	28	24	21	19
TP00010	.086	20	.71	28	23	20	18	16	14
H1/4U-SS0010		30	.87	34	28	24	21	19	17
		40	1.00	39	33	28	24	22	20
		50	1.12	44	36	32	28	24	22
		60	1.22	48	40	34	30	26	24
TP00015	.107	20	1.06	42	35	30	26	23	21
H1/4U-SS0015		30	1.30	51	42	36	32	28	26
		40	1.50	59	49	42	37	33	30
		50	1.68	66	55	47	41	36	33
		60	1.84	72	60	51	45	40	36
TP00020	.125	20	1.41	56	47	40	35		28
H1/4U-SS0020		30	1.73	68	57	50	43	38	34
		40	2.00	80	66	56	50	44	40
		50	2.24	88	74	64	56	49	44
		60	2.44	96	80	70	60	53	48
TP00030	.140	20	2.12	84	70	60	52		42
H1/4U-SS0030		30	2.60	102	86	74	64	57	51
		40	3.00		99	84	74	66	59

\*\*\*\* 15" ROW CONVERSION - X 2

\*\*\*\* 36" ROW CONVERSION - X .83

To determine the orifice plates you need, use the following equations:

**NOTE: Always insert Orifice Plate**  
with the side marked with the  
number facing the outlet.

$$\text{GPM (per nozzle)} = \frac{\text{GPA} \times \text{MPH} \times \text{W}}{5,940}$$

$$\text{GPA} = \frac{5,940 \times \text{GPM (per nozzle)}}{\text{MPH} \times \text{W}}$$

W = Nozzle spacing (in inches)  
for broadcast spraying.  
= Spray width (in inches) for  
single nozzle, band spraying  
or boomless spraying.  
= Row spacing (in inches) divided  
by the number of nozzles per row  
for directed spraying.

Tabulated flow rates are for spraying water into air at  
atmospheric pressure. If your application creates  
backpressure, or if spraying into a liquid, measure and  
calibrate to ensure proper application rates.

FOR ORIFICE SIZE	USE MESH SIZE
15 and smaller	200
16-39	100
40-70	50
72 and larger	—

	GPM						
	5 PSI	10 PSI	20 PSI	30 PSI	40 PSI	50 PSI	60 PSI
CP4916-008	0.003	0.004	0.006	0.007	0.008	0.009	0.010
CP4916-10	0.005	0.007	0.009	0.011	0.013	0.015	0.016
CP4916-12	0.007	0.010	0.013	0.016	0.019	0.021	0.023
CP4916-14	0.009	0.013	0.018	0.022	0.025	0.028	0.031
CP4916-15	0.010	0.015	0.021	0.025	0.029	0.032	0.036
CP4916-16	0.012	0.017	0.023	0.029	0.033	0.037	0.040
CP4916-18	0.015	0.021	0.030	0.036	0.042	0.047	0.051
CP4916-20	0.018	0.026	0.037	0.045	0.052	0.058	0.064
CP4916-22	0.022	0.031	0.043	0.053	0.061	0.068	0.075
CP4916-24	0.026	0.037	0.052	0.064	0.074	0.083	0.091
CP4916-25	0.028	0.040	0.056	0.068	0.079	0.088	0.097
CP4916-26	0.030	0.043	0.061	0.074	0.086	0.096	0.105
CP4916-27	0.032	0.046	0.064	0.079	0.091	0.102	0.111
CP4916-28	0.035	0.049	0.069	0.085	0.098	0.110	0.120
CP4916-29	0.038	0.054	0.076	0.094	0.108	0.121	0.132
CP4916-30	0.040	0.057	0.081	0.099	0.114	0.127	0.140
CP4916-31	0.043	0.062	0.087	0.107	0.123	0.138	0.151
CP4916-32	0.048	0.068	0.095	0.117	0.135	0.151	0.165
CP4916-34	0.052	0.074	0.104	0.127	0.147	0.164	0.180
CP4916-35	0.056	0.079	0.111	0.136	0.157	0.176	0.192
CP4916-37	0.061	0.086	0.122	0.149	0.172	0.192	0.211
CP4916-39	0.068	0.096	0.135	0.165	0.191	0.214	0.234
CP4916-40	0.072	0.102	0.144	0.177	0.204	0.228	0.250
CP4916-41	0.075	0.106	0.149	0.183	0.211	0.236	0.258
CP4916-43	0.082	0.116	0.163	0.200	0.231	0.258	0.283
CP4916-45	0.088	0.125	0.177	0.217	0.250	0.280	0.306
CP4916-46	0.095	0.135	0.191	0.234	0.270	0.302	0.331

	GPM						
	5 PSI	10 PSI	20 PSI	30 PSI	40 PSI	50 PSI	60 PSI
CP4916-47	0.097	0.138	0.194	0.238	0.275	0.307	0.337
CP4916-48	0.101	0.143	0.202	0.248	0.286	0.320	0.350
CP4916-49	0.104	0.148	0.209	0.255	0.295	0.330	0.361
CP4916-51	0.116	0.165	0.233	0.285	0.329	0.368	0.403
CP4916-52	0.118	0.168	0.237	0.290	0.335	0.375	0.410
CP4916-54	0.127	0.180	0.255	0.312	0.360	0.402	0.441
CP4916-55	0.133	0.189	0.267	0.326	0.377	0.421	0.462
CP4916-57	0.141	0.200	0.283	0.346	0.400	0.447	0.490
CP4916-59	0.153	0.217	0.306	0.375	0.433	0.484	0.530
CP4916-61	0.165	0.233	0.330	0.404	0.466	0.521	0.571
CP4916-63	0.174	0.246	0.347	0.425	0.491	0.549	0.601
CP4916-65	0.185	0.261	0.369	0.452	0.522	0.584	0.639
CP4916-67	0.196	0.278	0.392	0.481	0.555	0.621	0.680
CP4916-68	0.203	0.287	0.405	0.496	0.573	0.641	0.702
CP4916-70	0.216	0.306	0.433	0.530	0.612	0.684	0.750
CP4916-72	0.226	0.320	0.453	0.554	0.640	0.716	0.784
CP4916-73	0.233	0.330	0.467	0.572	0.660	0.738	0.808
CP4916-75	0.245	0.347	0.491	0.601	0.694	0.776	0.850
CP4916-78	0.272	0.385	0.544	0.667	0.770	0.861	0.943
CP4916-80	0.280	0.397	0.561	0.687	0.793	0.887	0.971
CP4916-81	0.290	0.411	0.581	0.711	0.821	0.918	1.01
CP4916-83	0.317	0.449	0.634	0.777	0.897	1.00	1.10
CP4916-86	0.332	0.470	0.664	0.813	0.939	1.05	1.15
CP4916-89	0.346	0.490	0.693	0.849	0.980	1.10	1.20
CP4916-91	0.369	0.523	0.739	0.905	1.05	1.17	1.28
CP4916-93	0.387	0.547	0.774	0.947	1.09	1.22	1.34
CP4916-95	0.404	0.572	0.808	0.990	1.14	1.28	1.40

	GPM						
	5 PSI	10 PSI	20 PSI	30 PSI	40 PSI	50 PSI	60 PSI
CP4916-98	0.442	0.625	0.884	1.08	1.25	1.40	1.53
CP4916-103	0.461	0.653	0.923	1.13	1.31	1.46	1.60
CP4916-107	0.518	0.733	1.04	1.27	1.47	1.64	1.79
CP4916-110	0.548	0.775	1.10	1.34	1.55	1.73	1.90
CP4916-115	0.605	0.855	1.21	1.48	1.71	1.91	2.09
CP4916-120	0.629	0.890	1.26	1.54	1.78	1.99	2.18
CP4916-125	0.693	0.980	1.39	1.70	1.96	2.19	2.40
CP4916-128	0.721	1.02	1.44	1.77	2.04	2.28	2.50
CP4916-132	0.774	1.10	1.55	1.90	2.19	2.45	2.68
CP4916-136	0.840	1.19	1.68	2.06	2.38	2.66	2.91
CP4916-140	0.894	1.27	1.79	2.19	2.53	2.83	3.10
CP4916-144	0.926	1.31	1.85	2.27	2.62	2.93	3.21
CP4916-147	0.953	1.35	1.91	2.33	2.70	3.01	3.30
CP4916-151	1.04	1.47	2.08	2.55	2.94	3.29	3.60
CP4916-156	1.10	1.55	2.20	2.69	3.11	3.47	3.80
CP4916-161	1.15	1.63	2.31	2.83	3.27	3.65	4.00
CP4916-166	1.21	1.72	2.43	2.97	3.43	3.84	4.20
CP4916-170	1.30	1.84	2.61	3.19	3.69	4.12	4.51
CP4916-172	1.36	1.92	2.71	3.32	3.84	4.29	4.70
CP4916-177	1.41	2.00	2.83	3.46	4.00	4.47	4.90
CP4916-182	1.47	2.08	2.95	3.61	4.17	4.66	5.10
CP4916-187	1.56	2.21	3.12	3.82	4.41	4.93	5.40
CP4916-196	1.73	2.45	3.46	4.24	4.90	5.47	6.00
CP4916-205	1.88	2.65	3.75	4.59	5.31	5.93	6.50
CP4916-218	2.11	2.98	4.21	5.16	5.96	6.66	7.30
CP4916-234	2.45	3.47	4.91	6.01	6.94	7.76	8.50
CP4916-250	2.83	4.00	5.66	6.93	8.00	8.94	9.80

# DLQ TONGUE - JACK AND HITCH OPTIONS

## 4410351 DLQ HOSE STAND ASSEMBLY

- TB 4435097 HOSE CADDY HOSE CLAMP
- 151811 BOLT, .375 NC X 2, G5, PLTD
- 152206 BOLT .5 NC X 1.5, G5, PLTD

### 4410378 PRESSURE GAUGE BRACKET ASSEMBLY, DLQ

- 4440967 .375 HOSE BARB, .25 NPT MALE, STAINLESS
- 4420323 GAUGE MOUNT BRACKET WELDMENT
- GG100 100 LB GLYCERIN FILLED GAUGE

- 151805 BOLT, .375 NC X 1.25, PLTD
- 4420325 HOSE STAND TOP WELDMENT
- 150005 NUT, .375 NC, PLTD
- 150008 NUT, .5 NC, PLTD
- 4420845 DLQ LONG HOSE STAND
- 4434269 HOSE STAND BACKING PLATE
- 152422 BOLT, .625 NC X 8, G5

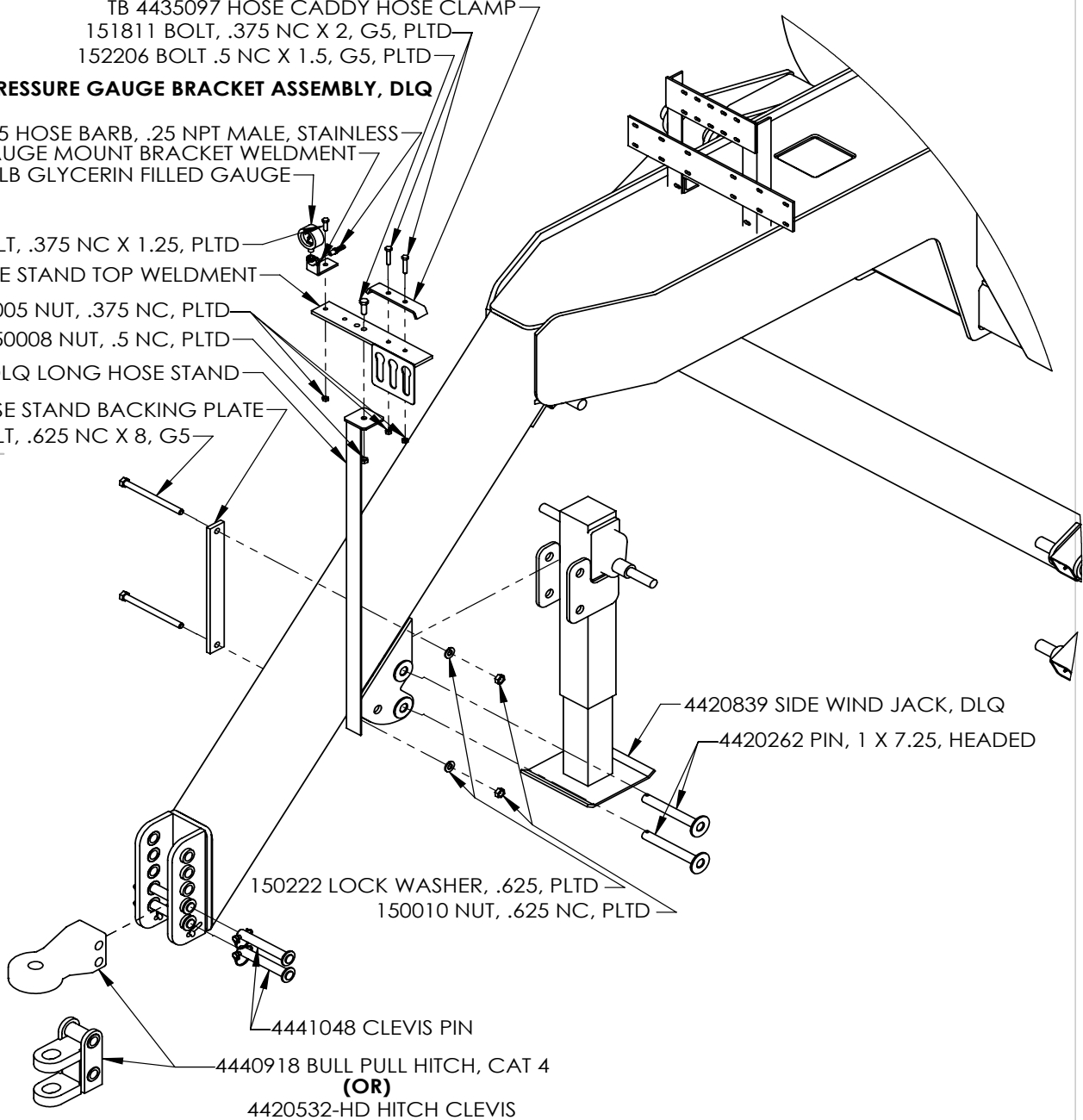

- 150222 LOCK WASHER, .625, PLTD
- 150010 NUT, .625 NC, PLTD

- 4420839 SIDE WIND JACK, DLQ
- 4420262 PIN, 1 X 7.25, HEADED

- 4441048 CLEVIS PIN
- 4440918 BULL PULL HITCH, CAT 4  
(OR)  
4420532-HD HITCH CLEVIS

Available:  
4441023 SAFETY CHAIN, PAIR

DRAWN BY	RICH SMOTHERS	6/2/2014
CHECKED BY		
PRINT DATE	5/31/2017	
CONFIG.	Default	
COMMENTS:		



**PROPRIETARY AND CONFIDENTIAL**  
THE INFORMATION CONTAINED IN THIS DRAWING IS THE SOLE PROPERTY OF DALTON AG. ANY REPRODUCTION IN PART OR AS A WHOLE WITHOUT THE WRITTEN PERMISSION OF DALTON AG IS PROHIBITED.

DWG: DLQ TONGUE - JACK AND HITCH OPTIONS		
SIZE <b>A</b>	SHEET TITLE: Sheet1	REV <b>A</b>
SCALE: 1:16	SHEET 1 OF 1	

# DLQ TOOLBAR CONTROL ARM

- 4420842 RAVEN VALVE MOUNT, 3 SHUT-OFF  
(OR)
- 4420917 RAVEN VALVE MOUNT, 5 SHUT-OFF
- 4420840 DLQ FLOW MONITOR PANEL, 1  
(OR)
- 4420841 DLQ FLOW MONITOR PANEL, 2

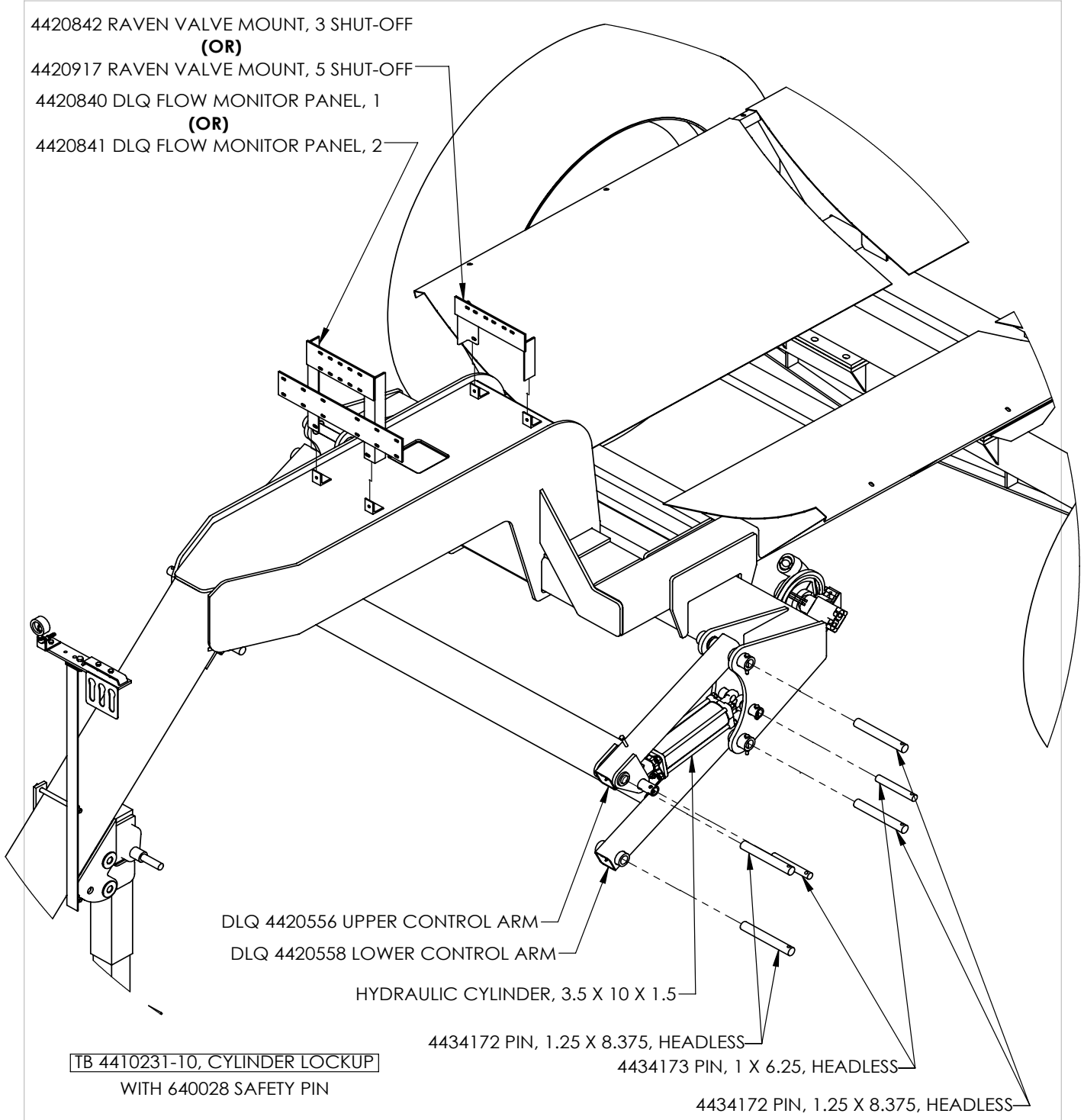

DLQ 4420556 UPPER CONTROL ARM  
DLQ 4420558 LOWER CONTROL ARM

HYDRAULIC CYLINDER, 3.5 X 10 X 1.5

4434172 PIN, 1.25 X 8.375, HEADLESS

4434173 PIN, 1 X 6.25, HEADLESS

4434172 PIN, 1.25 X 8.375, HEADLESS

TB 4410231-10, CYLINDER LOCKUP  
WITH 640028 SAFETY PIN

DRAWN BY	RICH SMOTHERS	6/2/2014
CHECKED BY		
PRINT DATE	5/19/2017	
CONFIG.	Default	
COMMENTS:		



**PROPRIETARY AND CONFIDENTIAL**  
THE INFORMATION CONTAINED IN THIS DRAWING IS THE SOLE PROPERTY OF DALTON AG. ANY REPRODUCTION IN PART OR AS A WHOLE WITHOUT THE WRITTEN PERMISSION OF DALTON AG IS PROHIBITED.

DWG: DLQ HD TOOLBAR CONTROL ARM

SIZE <b>A</b>	SHEET TITLE: Sheet1	REV <b>A</b>
SCALE: 1:18	SHEET 1 OF 1	

# DLQSTD AXLE, SPINDLE, AND HUB

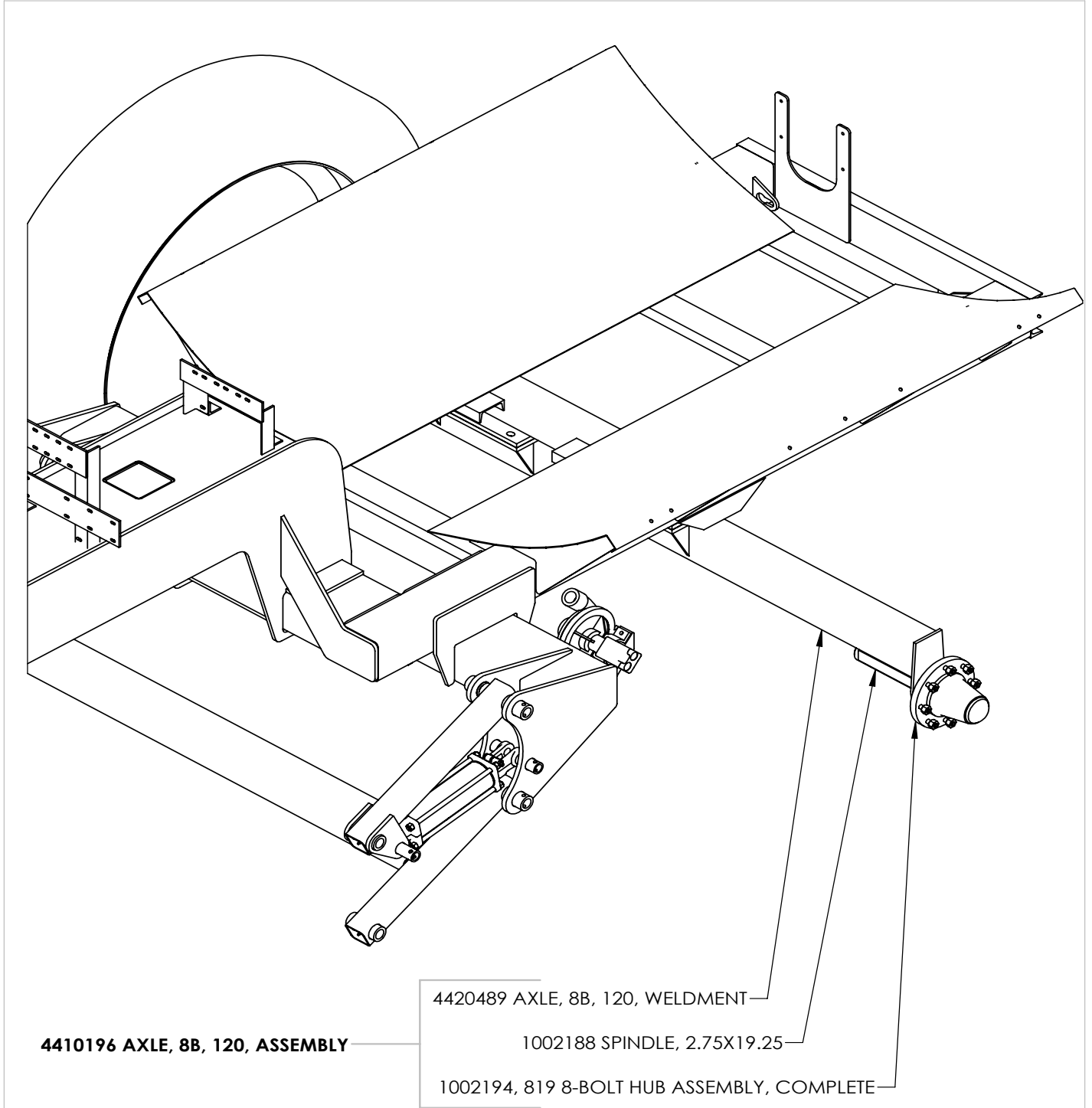

**4410196 AXLE, 8B, 120, ASSEMBLY**

4420489 AXLE, 8B, 120, WELDMENT

1002188 SPINDLE, 2.75X19.25

1002194, 819 8-BOLT HUB ASSEMBLY, COMPLETE

DRAWN BY	RICH SMOTHERS	9/18/2015
CHECKED BY		
PRINT DATE	3/17/2017	
CONFIG.	Default	
COMMENTS:		



**PROPRIETARY AND CONFIDENTIAL**  
 THE INFORMATION CONTAINED IN THIS DRAWING IS THE SOLE PROPERTY OF DALTON AG. ANY REPRODUCTION IN PART OR AS A WHOLE WITHOUT THE WRITTEN PERMISSION OF DALTON AG IS PROHIBITED.

DWG: DLQSTD AXLE, SPINDLE, AND HUB

SIZE	SHEET TITLE:	REV
<b>A</b>	Sheet1	<b>A</b>
SCALE: 1:16	SHEET 1 OF 1	



# 1002194, 819 8-BOLT HUB ASSEMBLY, COMPLETE

1002194, 819 8-BOLT HUB ASSEMBLY, COMPLETE

4450041\_HUB\_REBUILD\_KIT  
 -INCLUDES BEARINGS, RACES, AND SEALS

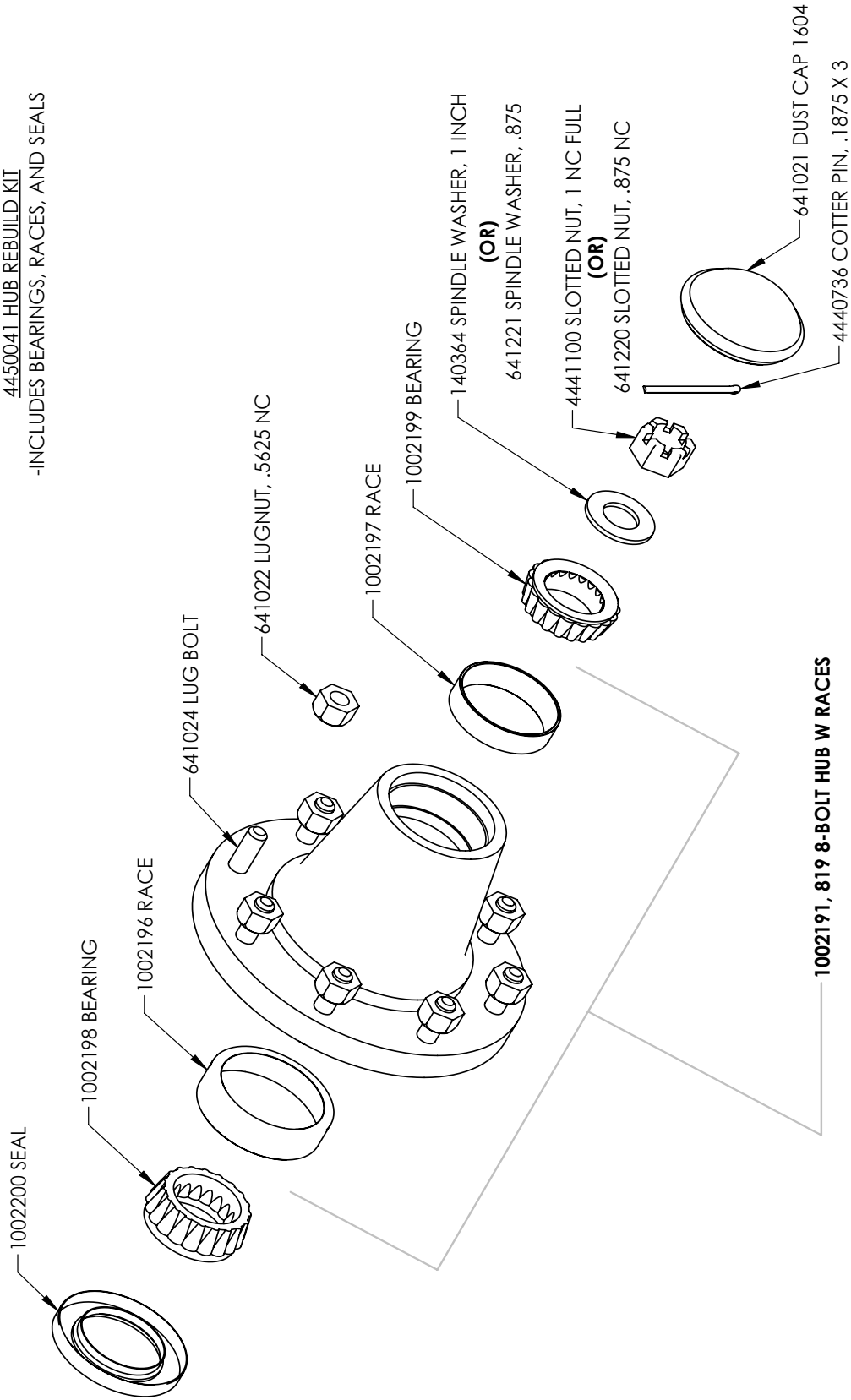

<b>1002194, 819 8-BOLT HUB ASSEMBLY, COMPLETE</b>		DRAWN BY	RICH SMOTHERS	5/14/2009
<b>PROPRIETARY AND CONFIDENTIAL</b> THE INFORMATION CONTAINED IN THIS DRAWING IS THE SOLE PROPERTY OF DALTON A.G. ANY REPRODUCTION IN PART OR AS A WHOLE WITHOUT THE WRITTEN PERMISSION OF DALTON A.G IS PROHIBITED.		CHECKED BY		
		PRINT DATE	12/2/2016	
		CONFIG.	Default	
COMMENTS:		DWG: 1002194, 819 8-BOLT HUB ASSEMBLY, COMPLETE SIZE SHEET TITLE: A Sheet1 SCALE: 1:4 SHEET 1 OF 1		

# DLQHD AXLE, SPINDLE, AND HUB (EXCLUDING DLQHD 2000)

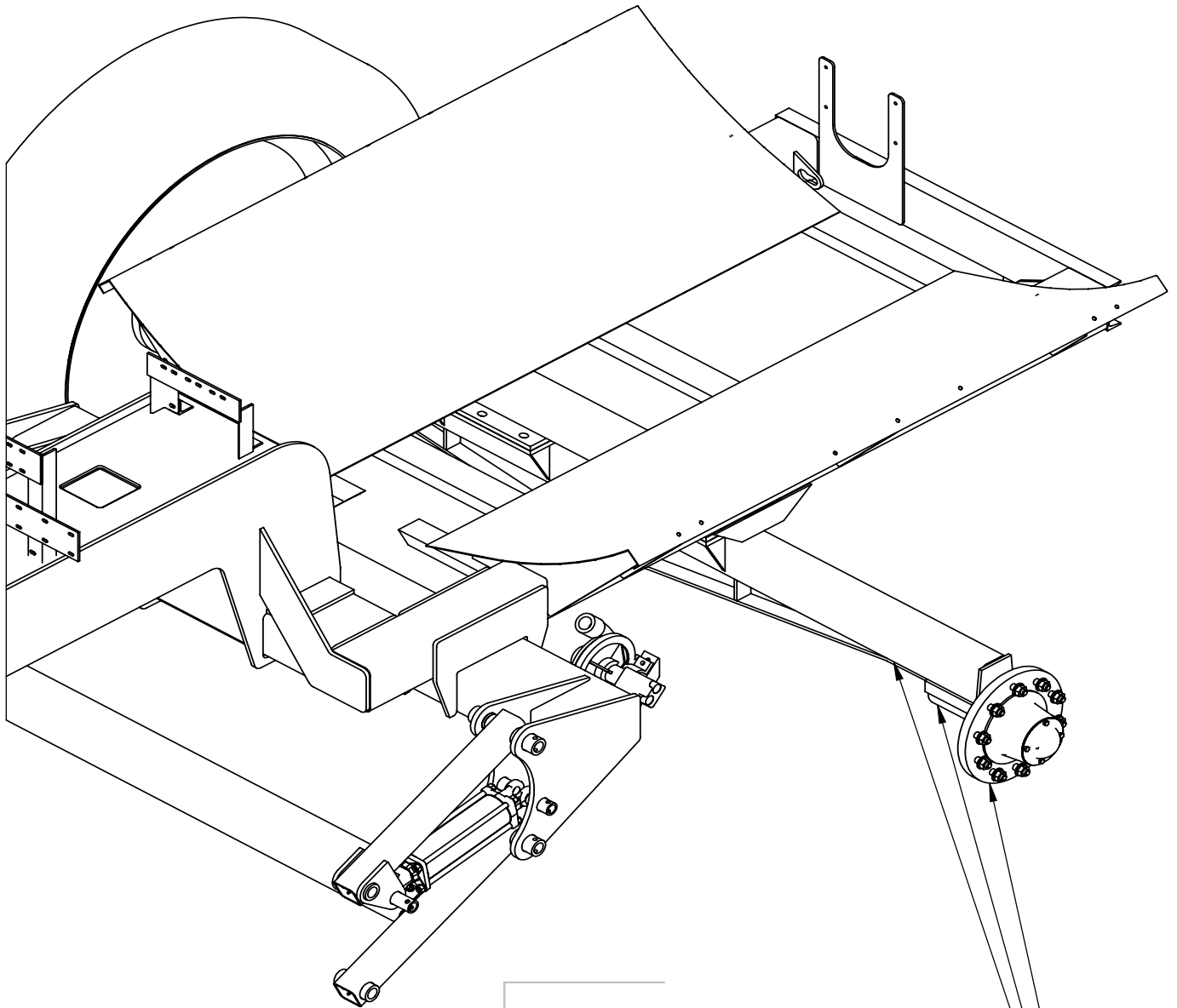

**4410352 AXLE, 10B, 120, TRUSSED, ASSEMBLY**

4420492 AXLE, 10B, 120, TRUSSED, WELDMENT

S-5296-L-12 SPINDLE, 3.50X16

4410248, 873 10-BOLT HUB ASSEMBLY, COMPLETE

DRAWN BY	RICH SMOTHERS	1/21/2015
CHECKED BY		
PRINT DATE	3/17/2017	
CONFIG.	Default	
COMMENTS:		



DWG: DLQHD AXLE, SPINDLE, AND HUB

**PROPRIETARY AND CONFIDENTIAL**  
THE INFORMATION CONTAINED IN THIS DRAWING IS THE SOLE PROPERTY OF DALTON AG. ANY REPRODUCTION IN PART OR AS A WHOLE WITHOUT THE WRITTEN PERMISSION OF DALTON AG IS PROHIBITED.

SIZE <b>A</b>	SHEET TITLE: Sheet1	REV <b>A</b>
SCALE: 1:16		SHEET 1 OF 1

# 4410248, 873 10-BOLT HUB ASSEMBLY, COMPLETE

4410248, 873 10-BOLT HUB ASSEMBLY, COMPLETE

4450043 HUB REBUILD KIT

-INCLUDES BEARINGS, RACES, AND SEALS

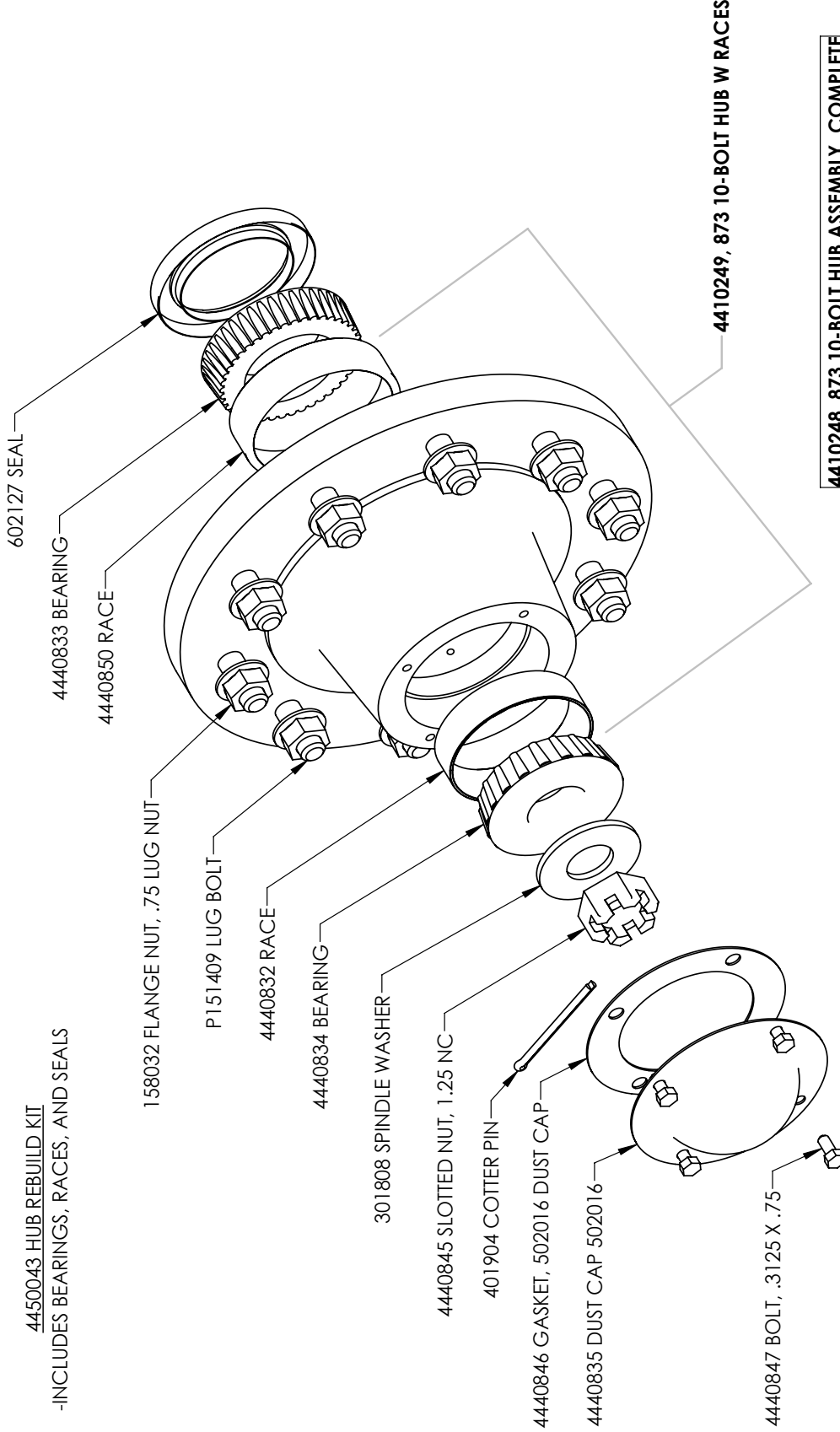

**4410248, 873 10-BOLT HUB ASSEMBLY, COMPLETE**

DRAWN BY	RICH SMOTHERS	5/4/2009
CHECKED BY		
PRINT DATE	12/5/2016	
CONFIG.	Default	
COMMENTS:		



DWG: 4410248, 873 10-BOLT HUB ASSEMBLY, COMPLETE

SIZE	A	SHEET TITLE:	Sheet1	REV	A
SCALE:	1:4			SHEET 1 OF 1	

**PROPRIETARY AND CONFIDENTIAL**  
 THE INFORMATION CONTAINED IN THIS DRAWING IS THE SOLE PROPERTY OF DALTON A.G. ANY REPRODUCTION IN PART OR AS A WHOLE WITHOUT THE WRITTEN PERMISSION OF DALTON A.G IS PROHIBITED.

# DLQHD 2000 AXLE, SPINDLE, AND HUB

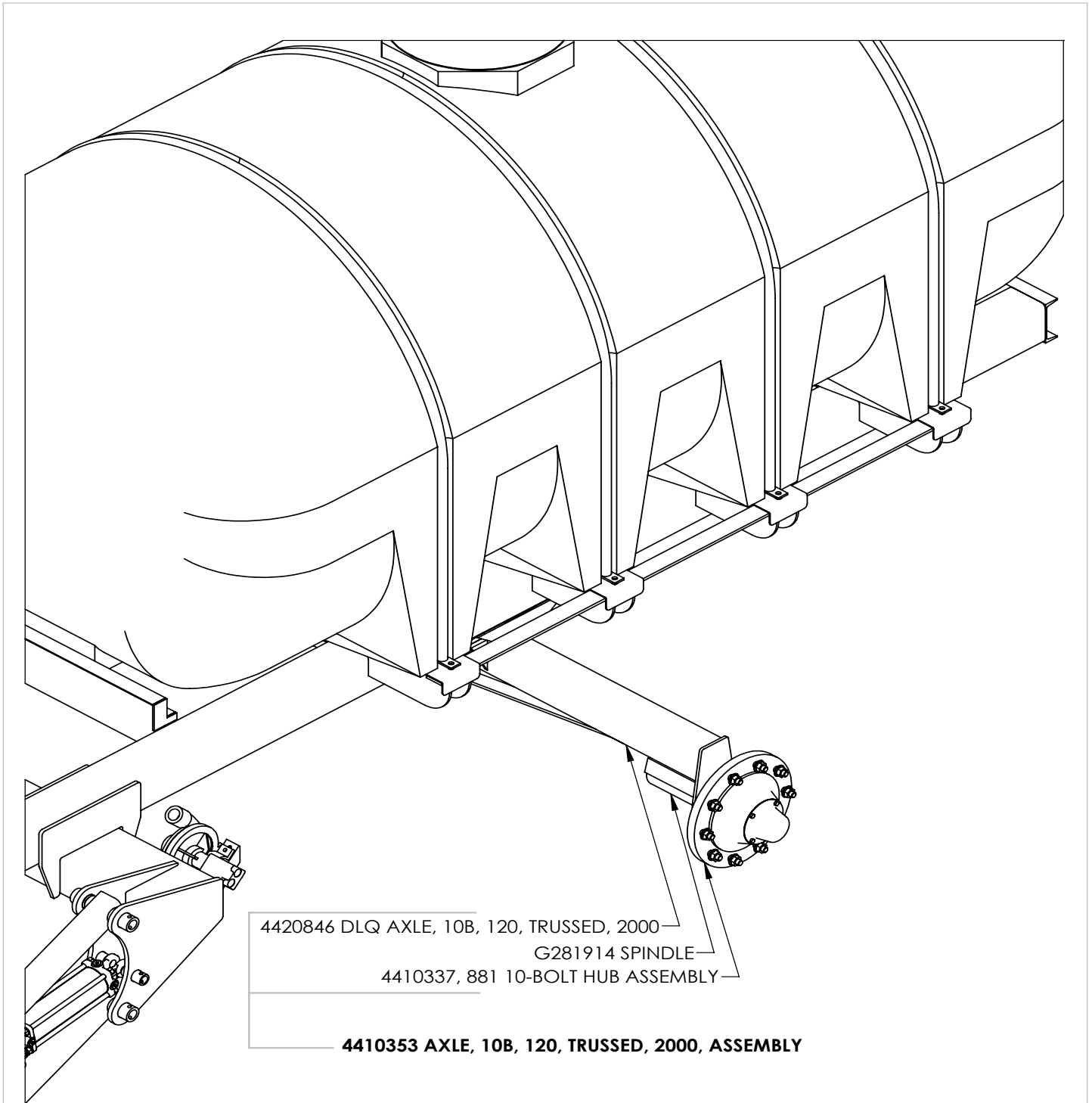

4420846 DLQ AXLE, 10B, 120, TRUSSED, 2000  
 G281914 SPINDLE  
 4410337, 881 10-BOLT HUB ASSEMBLY  
  
**4410353 AXLE, 10B, 120, TRUSSED, 2000, ASSEMBLY**

DRAWN BY	RICH SMOTHERS	6/2/2014
CHECKED BY		
PRINT DATE	3/17/2017	
CONFIG.	Default	
COMMENTS:		



DWG: DLQHD 2000 AXLE, SPINDLE, AND HUB

**PROPRIETARY AND CONFIDENTIAL**  
 THE INFORMATION CONTAINED IN THIS DRAWING IS THE SOLE PROPERTY OF DALTON AG. ANY REPRODUCTION IN PART OR AS A WHOLE WITHOUT THE WRITTEN PERMISSION OF DALTON AG IS PROHIBITED.

SIZE <b>A</b>	SHEET TITLE: Sheet1	REV <b>A</b>
SCALE: 1:16		SHEET 1 OF 1

# 4410337, 881 10-BOLT HUB ASSEMBLY, COMPLETE

4410337, 881 10-BOLT HUB ASSEMBLY

4450044 HUB REBUILD KIT  
-INCLUDES BEARINGS, RACES, AND SEALS

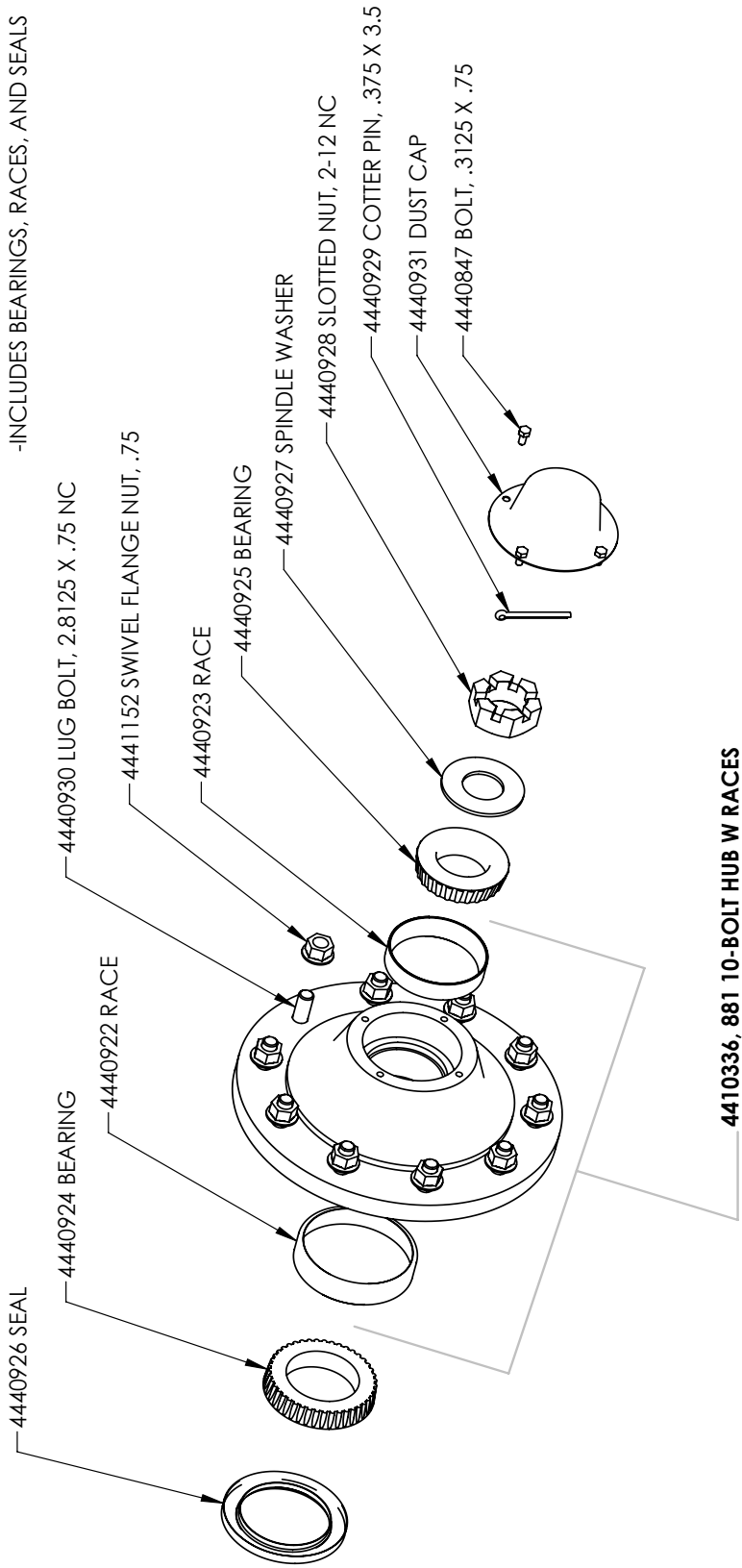

**4410337, 881 10-BOLT HUB ASSEMBLY**

DRAWN BY	RICH SMOTHERS	5/18/2015	 <p>602 E. VAN BUREN ST., LENOX, IA 50851</p>						
CHECKED BY									
PRINT DATE	12/13/2017								
CONFIG.	Default								
COMMENTS:	4410337, 881 10-BOLT HUB ASSEMBLY			DWG:					
<b>PROPRIETARY AND CONFIDENTIAL</b> THE INFORMATION CONTAINED IN THIS DRAWING IS THE SOLE PROPERTY OF DALTON A.G. ANY REPRODUCTION IN PART OR AS A WHOLE WITHOUT THE WRITTEN PERMISSION OF DALTON A.G IS PROHIBITED.	SIZE	A	SHEET TITLE:	Sheet1	REV	A			
	SCALE:	1:8	SHEET 1 OF 1						
	1		2		3		4		5

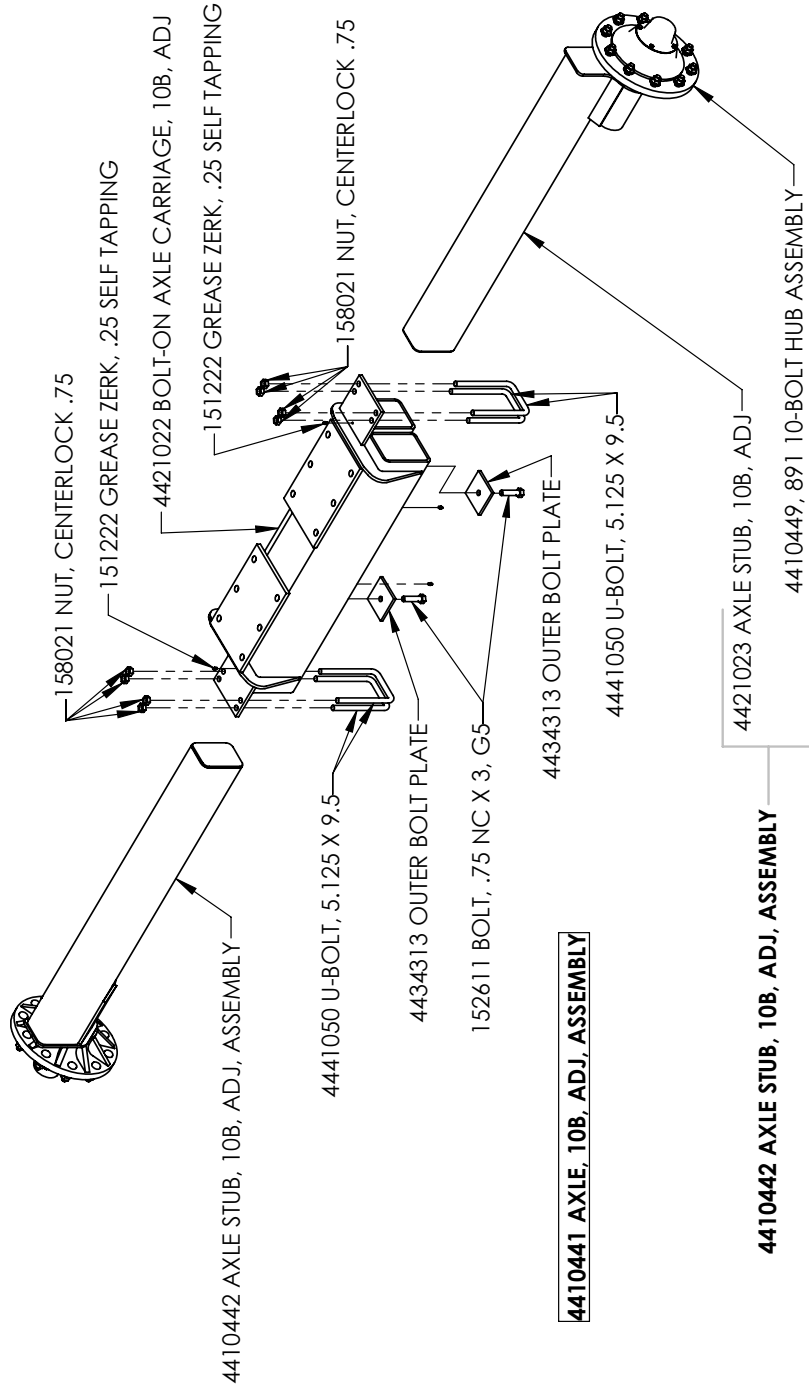

DRAWN BY	RICH SMOTHERS	2/14/2017
CHECKED BY		
PRINT DATE	2/16/2017	
CONFIG.	Default	
COMMENTS:		

**Dalton**  
 USA  
 602 E. VAN BUREN ST., LENOX, IA 50651  
 DWG: DLQ ADJUSTABLE AXLE

<b>PROPRIETARY AND CONFIDENTIAL</b>		SIZE	SHEET TITLE:	REV
THE INFORMATION CONTAINED IN THIS DRAWING IS THE SOLE PROPERTY OF DALTON AG. ANY REPRODUCTION IN PART OR AS A WHOLE WITHOUT THE WRITTEN PERMISSION OF DALTON AG IS PROHIBITED.		<b>A</b>	Sheet1	
SCALE: 1:24				SHEET 1 OF 1

5	4	3	2	1
---	---	---	---	---

# 4410449, 891 10-BOLT HUB ASSEMBLY, COMPLETE

4410449, 891 10-BOLT HUB ASSEMBLY

4450044 HUB REBUILD KIT  
-INCLUDES BEARINGS, RACES, AND SEALS

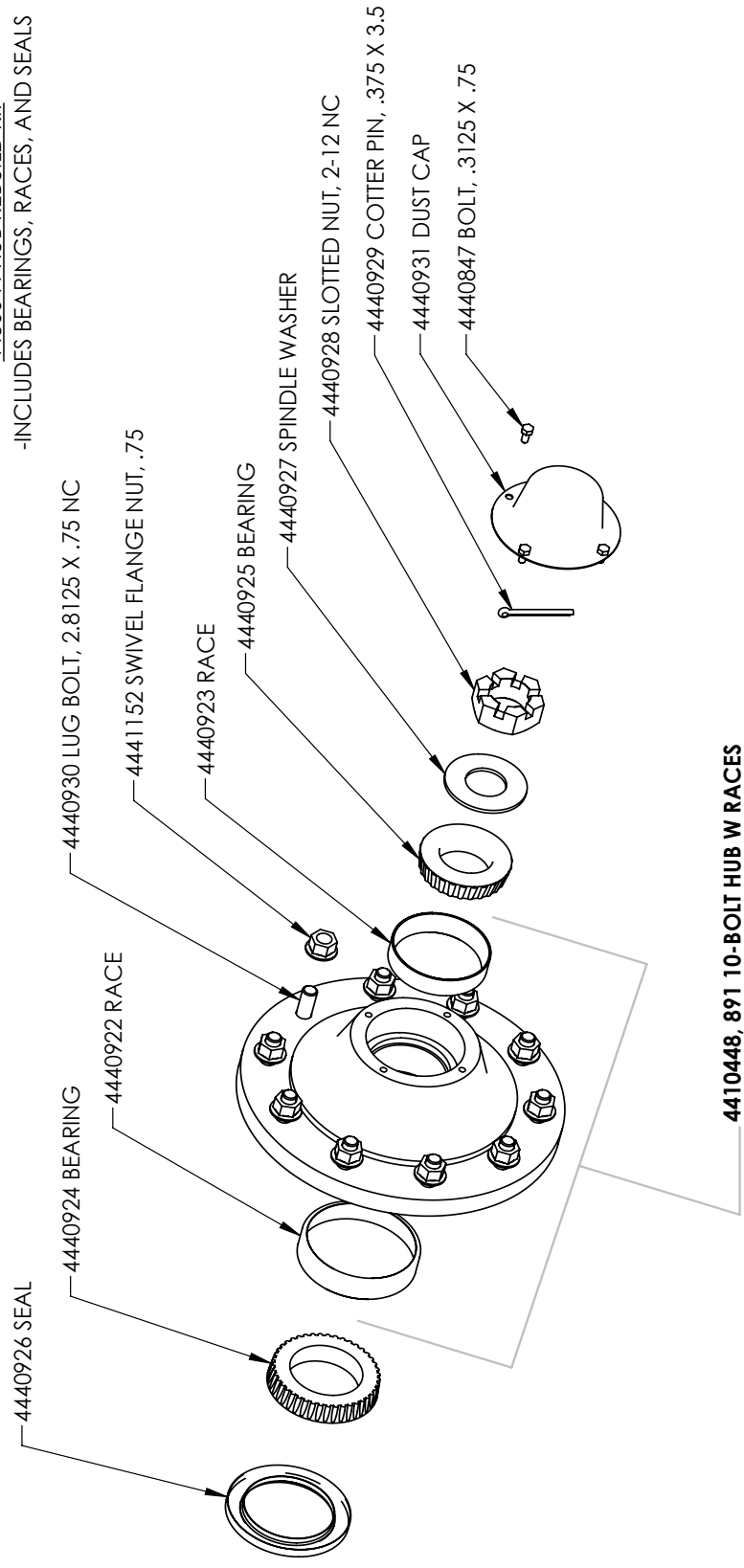

**4410449, 891 10-BOLT HUB ASSEMBLY**

DRAWN BY	RICH SMOTHERS	5/18/2015		
CHECKED BY				
PRINT DATE	12/13/2017			
CONFIG.	Default			
COMMENTS:				
<p><b>PROPRIETARY AND CONFIDENTIAL</b> THE INFORMATION CONTAINED IN THIS DRAWING IS THE SOLE PROPERTY OF DALTON A.G. ANY REPRODUCTION IN PART OR AS A WHOLE WITHOUT THE WRITTEN PERMISSION OF DALTON A.G IS PROHIBITED.</p>				
<p>DWG: 4410449, 891 10-BOLT HUB ASSEMBLY</p>				
SIZE	A	SHEET TITLE:	Sheet1	REV
SCALE:	1:8			A
				SHEET 1 OF 1



# DLQ SINGLE FOLD TOOLBAR

DLQ SINGLE LIFT TOOLBAR

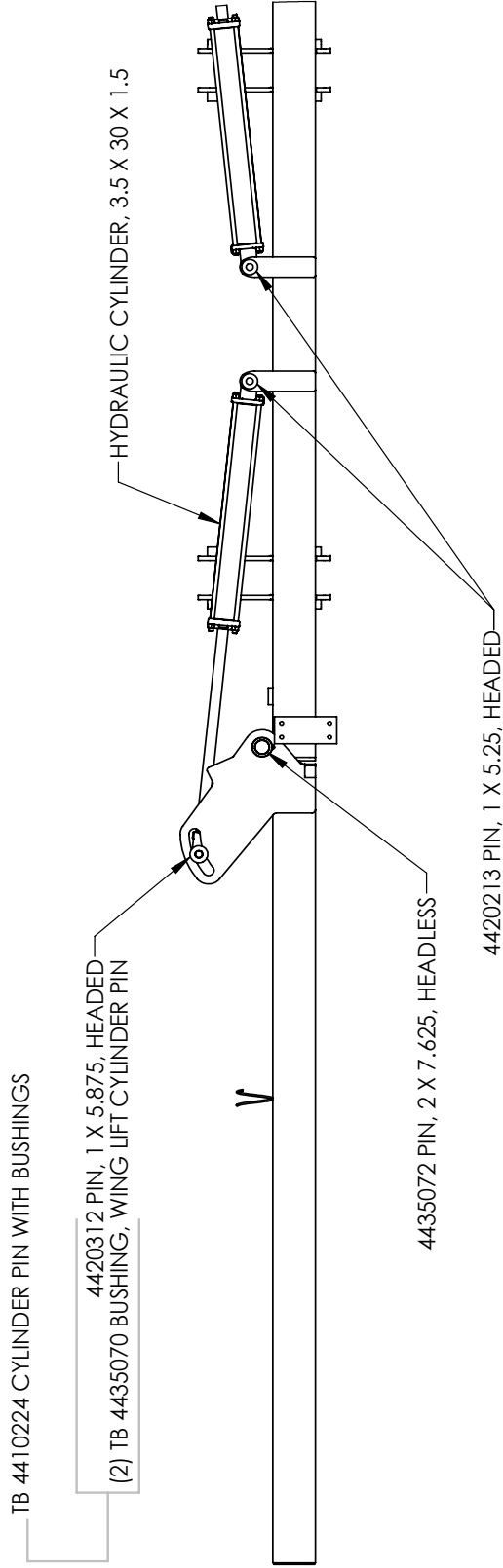

DRAWN BY RICH SMOTHERS		6/12/2015	 DALTON USA 602 E. VAN BUREN ST., LENOX, IA 50851	
CHECKED BY		5/19/2017		
PRINT DATE			DWG: DLQ SINGLE LIFT TOOLBAR	
CONFIG. Default			SIZE SHEET TITLE: Sheet1	
COMMENTS:			REV A	
<b>PROPRIETARY AND CONFIDENTIAL</b> THE INFORMATION CONTAINED IN THIS DRAWING IS THE SOLE PROPERTY OF DALTON A.G. ANY REPRODUCTION IN PART OR AS A WHOLE WITHOUT THE WRITTEN PERMISSION OF DALTON A.G IS PROHIBITED.			SCALE: 1:24	
			SHEET 1 OF 1	

5	4	3	2	1
---	---	---	---	---



# DLQ FRONT FOLD TOOLBAR

DLQ FRONT FOLD TOOLBAR

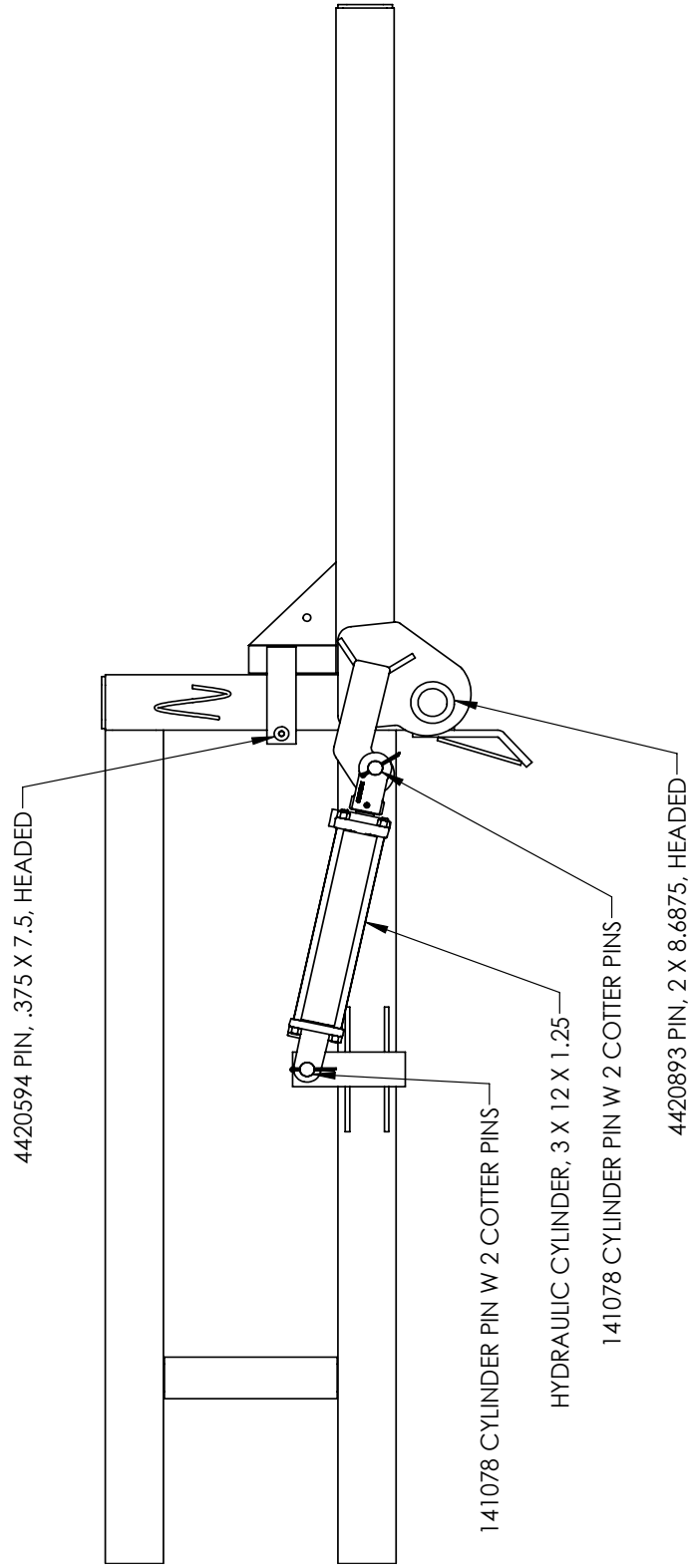

DRAWN BY RICH SMOTHERS	9/25/2015	DALTON 602 E. VAN BUREN ST., LENOX, IA 50851	DWG: DLQ FRONT FOLD TOOLBAR
CHECKED BY	9/19/2017	SIZE <b>A</b>	SHEET TITLE: Sheet1
PRINT DATE	Default	SCALE: 1:12	REV <b>A</b>
CONFIG. Default		COMMENTS:	
<p style="font-size: small; margin: 0;"> <b>PROPRIETARY AND CONFIDENTIAL</b>                      THE INFORMATION CONTAINED IN THIS DRAWING IS THE SOLE PROPERTY OF DALTON A.G. ANY REPRODUCTION IN PART OR AS A WHOLE WITHOUT THE WRITTEN PERMISSION OF DALTON A.G IS PROHIBITED.                 </p>			
5	4	3	2
			SHEET 1 OF 1

# DLQ DOUBLE FOLD TOOLBAR

DLQ DOUBLE LIFT TOOLBAR

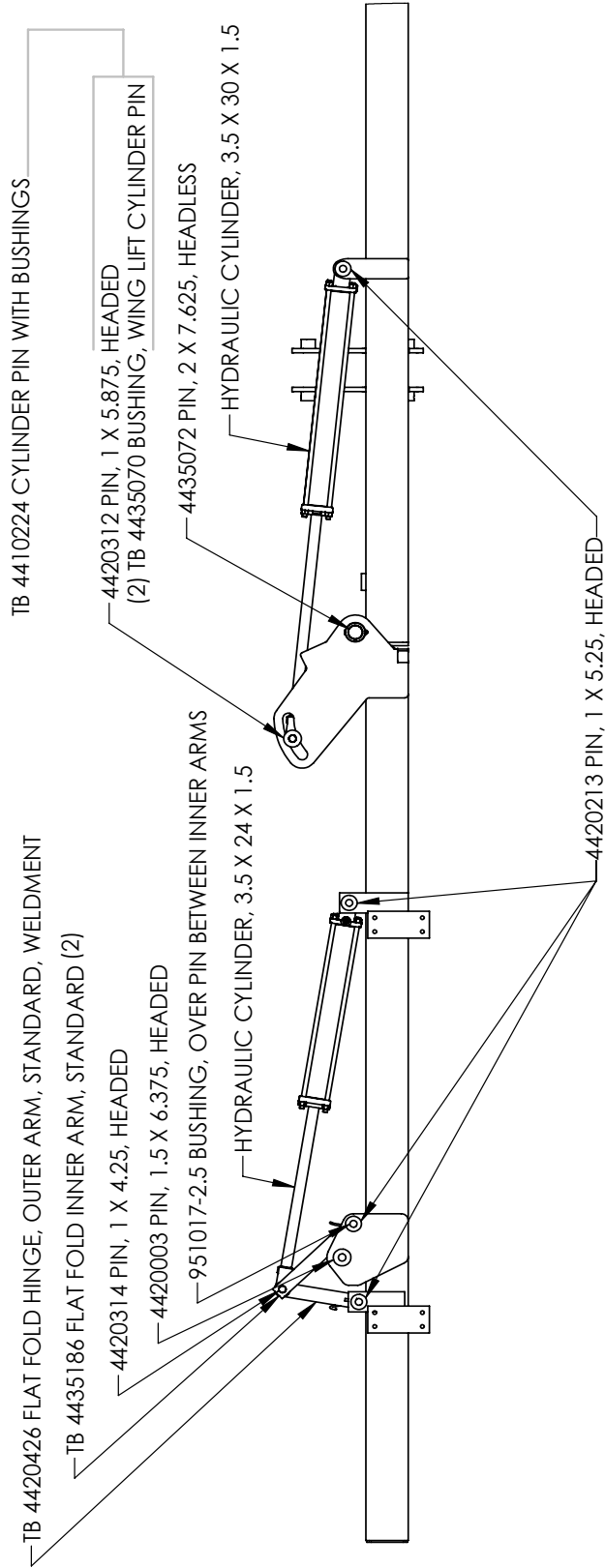

DRAWN BY	RICH SMOTHERS	6/12/2015
CHECKED BY		
PRINT DATE	5/19/2017	
CONFIG.	Default	



DWG: DLQ DOUBLE LIFT TOOLBAR

**PROPRIETARY AND CONFIDENTIAL**  
 THE INFORMATION CONTAINED IN THIS DRAWING IS THE SOLE PROPERTY OF DALTON A.G. ANY REPRODUCTION IN PART OR AS A WHOLE WITHOUT THE WRITTEN PERMISSION OF DALTON A.G IS PROHIBITED.

SIZE	A	SHEET TITLE:	Sheet1	REV	A
SCALE:	1:24	SHEET 1 OF 1			

5

4

3

2

1

# DLQHD 60' TOOLBAR

DLQHD - 60 FOOT TOOLBAR

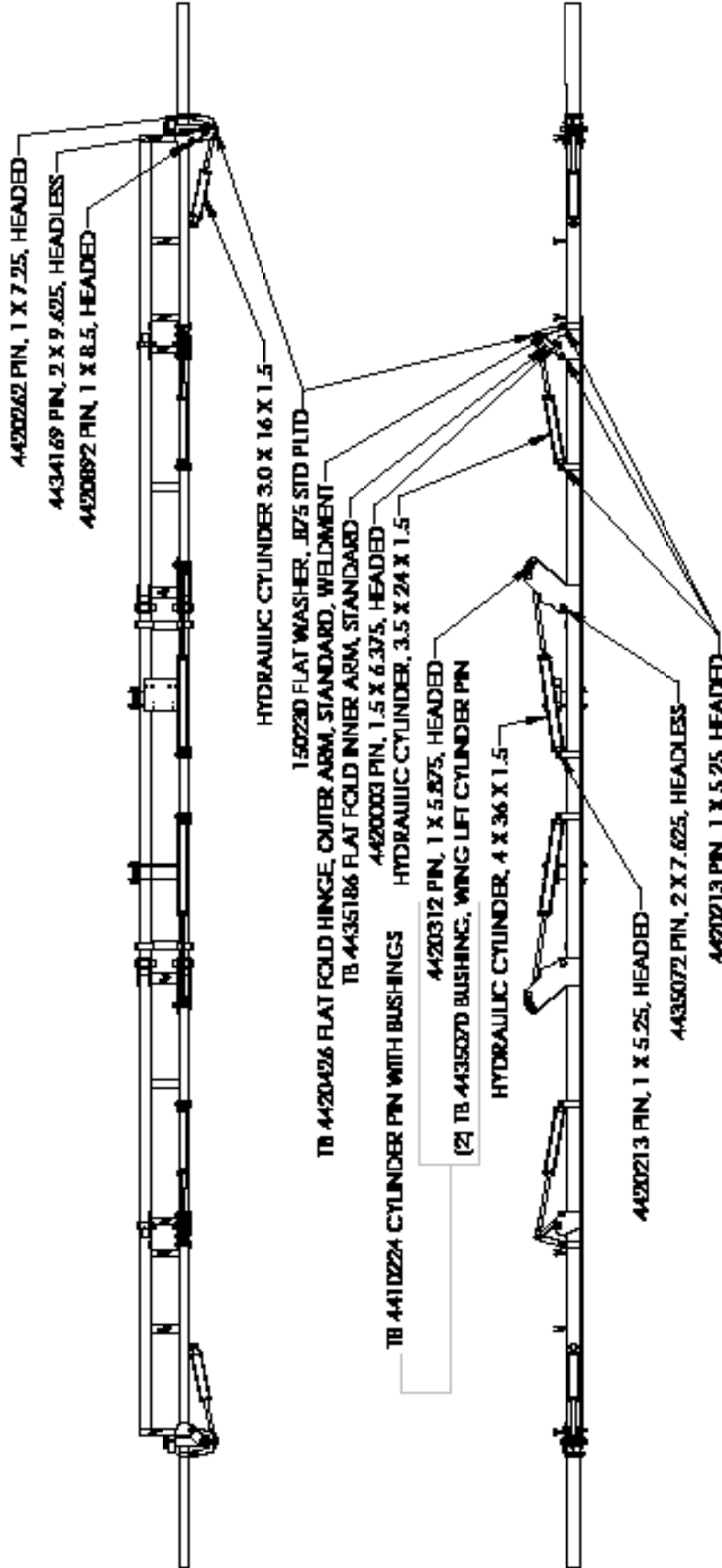

DRAWN BY: BICH SMOTHERS CHECKED BY: PUBLISH DATE: 5/19/2017 CONFIG: Default COMMENTS:	6282014 5/19/2017 Default COMMENTS:	DALTON USA MANUFACTURING, LINCOLN, NE 68501	DWG: DLQHD - 60 FOOT TOOLBAR SIZE: A SHEET TITLE: Sheet1 SCALE: 1:66 SHEET 1 OF 1	REV: A SHEET 1 OF 1
PROPRIETARY AND CONFIDENTIAL THE INFORMATION CONTAINED IN THIS DRAWING IS THE SOLE PROPERTY OF DALTON AND ANY REPRODUCTION IN PART OR AS A WHOLE WITHOUT THE WRITTEN PERMISSION OF DALTON IS PROHIBITED.				

# TOOLBAR CYLINDER STOP

SUBWELDMENT

TOOLBAR CYLINDER STOP

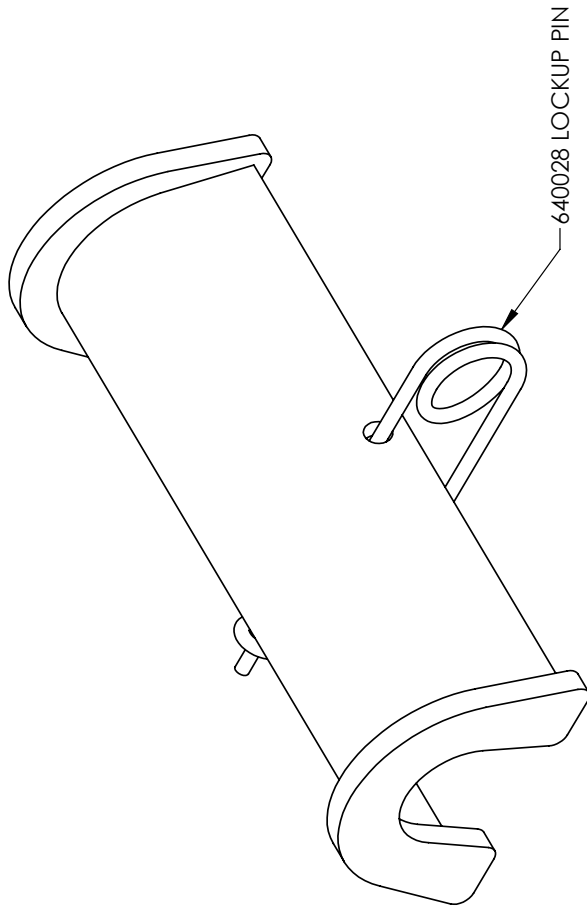

**TB 4410231 - 10, CYLINDER LOCKUP**

DRAWN BY	Jeremy Newton	2/14/2017
CHECKED BY		
PRINT DATE	2/16/2017	
CONFIG.	Default	
COMMENTS:		

  
 DALTON TUBULAR FABRICATORS
   
 602 E. VAN BUREN ST., LENOX, IA 50651
   
 DWG: TOOLBAR CYLINDER STOP

SIZE	A	SHEET TITLE:	Sheet1	REV
SCALE:	1:2			SHEET 1 OF 1

**PROPRIETARY AND CONFIDENTIAL**  
 THE INFORMATION CONTAINED IN THIS DRAWING IS THE SOLE PROPERTY OF DALTON AG. ANY REPRODUCTION IN PART OR AS A WHOLE WITHOUT THE WRITTEN PERMISSION OF DALTON AG IS PROHIBITED.

5 4 3 2 1

# DLQ LIGHT KIT

ASSEMBLY

DLQ LIGHT KIT

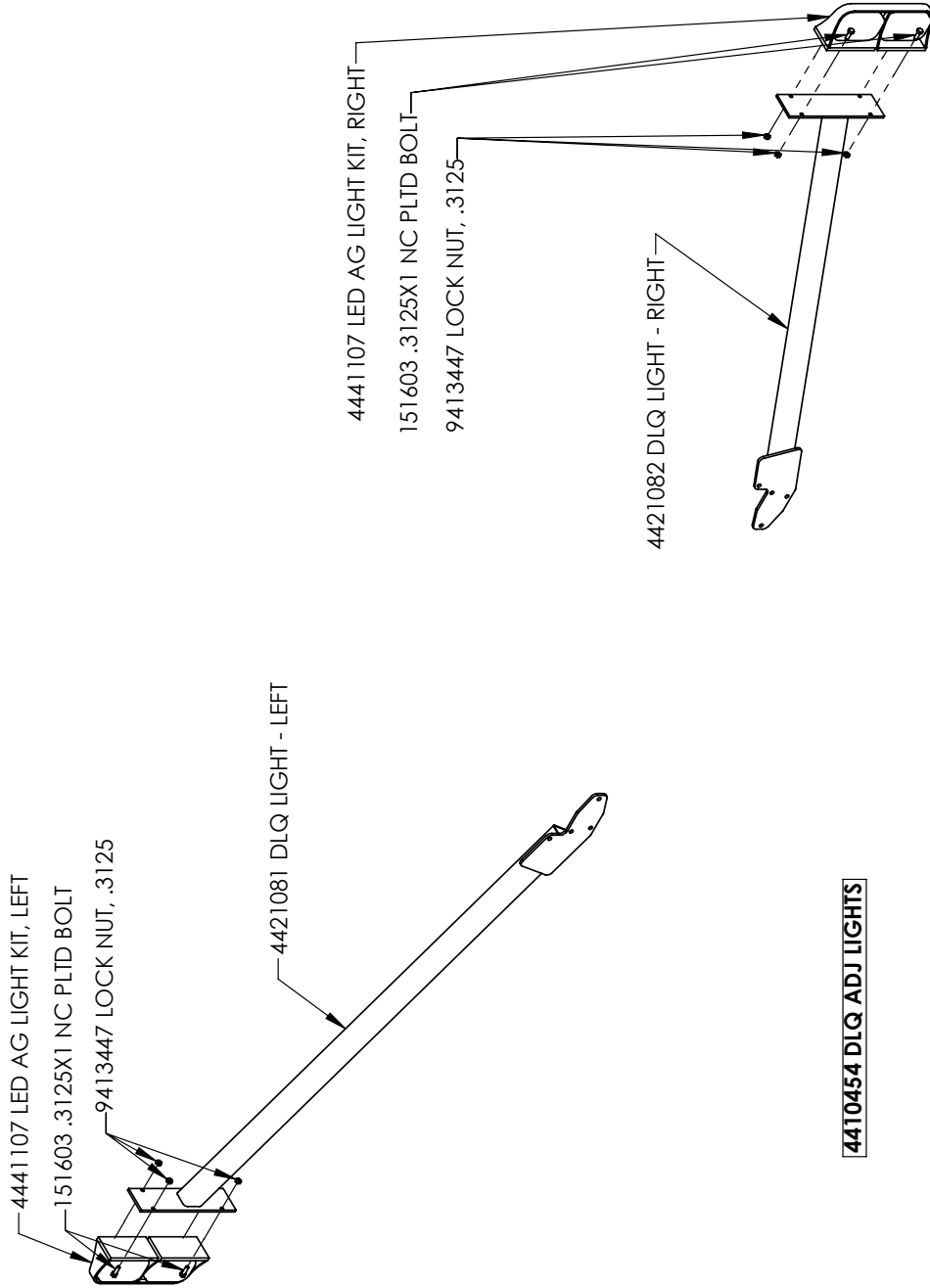

DRAWN BY RICH SMOTHERS CHECKED BY PRINT DATE 5/24/2017 CONFIG. Default COMMENTS:	2/16/2017 5/24/2017 Default	DALTON 602 E. VAN BUREN ST., LENOX, IA 50651	DLQ LIGHT KIT DWG:
<p><b>4410454 DLQ ADJ LIGHTS</b></p>		<p><b>4421082 DLQ LIGHT - RIGHT</b></p>	
<p><b>4421081 DLQ LIGHT - LEFT</b></p>		<p><b>4441107 LED AG LIGHT KIT, RIGHT</b></p>	
<p><b>4441107 LED AG LIGHT KIT, LEFT</b></p>		<p><b>4421082 DLQ LIGHT - RIGHT</b></p>	
<p><b>4410454 DLQ ADJ LIGHTS</b></p>		<p><b>4421081 DLQ LIGHT - LEFT</b></p>	
<p><b>4441107 LED AG LIGHT KIT, LEFT</b></p>		<p><b>4441107 LED AG LIGHT KIT, RIGHT</b></p>	
<p><b>151603 .3125X1 NC PLTD BOLT</b></p>		<p><b>151603 .3125X1 NC PLTD BOLT</b></p>	
<p><b>9413447 LOCK NUT, .3125</b></p>		<p><b>9413447 LOCK NUT, .3125</b></p>	
<p><b>4421081 DLQ LIGHT - LEFT</b></p>		<p><b>4421082 DLQ LIGHT - RIGHT</b></p>	
<p><b>4441107 LED AG LIGHT KIT, LEFT</b></p>		<p><b>4441107 LED AG LIGHT KIT, RIGHT</b></p>	
<p><b>4421082 DLQ LIGHT - RIGHT</b></p>		<p><b>4421081 DLQ LIGHT - LEFT</b></p>	
<p><b>4410454 DLQ ADJ LIGHTS</b></p>		<p><b>4410454 DLQ ADJ LIGHTS</b></p>	
<p><b>PROPRIETARY AND CONFIDENTIAL</b></p> <p>THE INFORMATION CONTAINED IN THIS DRAWING IS THE SOLE PROPERTY OF DALTON AG. ANY REPRODUCTION IN PART OR AS A WHOLE WITHOUT THE WRITTEN PERMISSION OF DALTON AG IS PROHIBITED.</p>			
SIZE SHEET TITLE: Sheet1 REV		SCALE: 1:16 SHEET 1 OF 1	

# CYLINDER LINKAGE AND DOWNPRESSURE

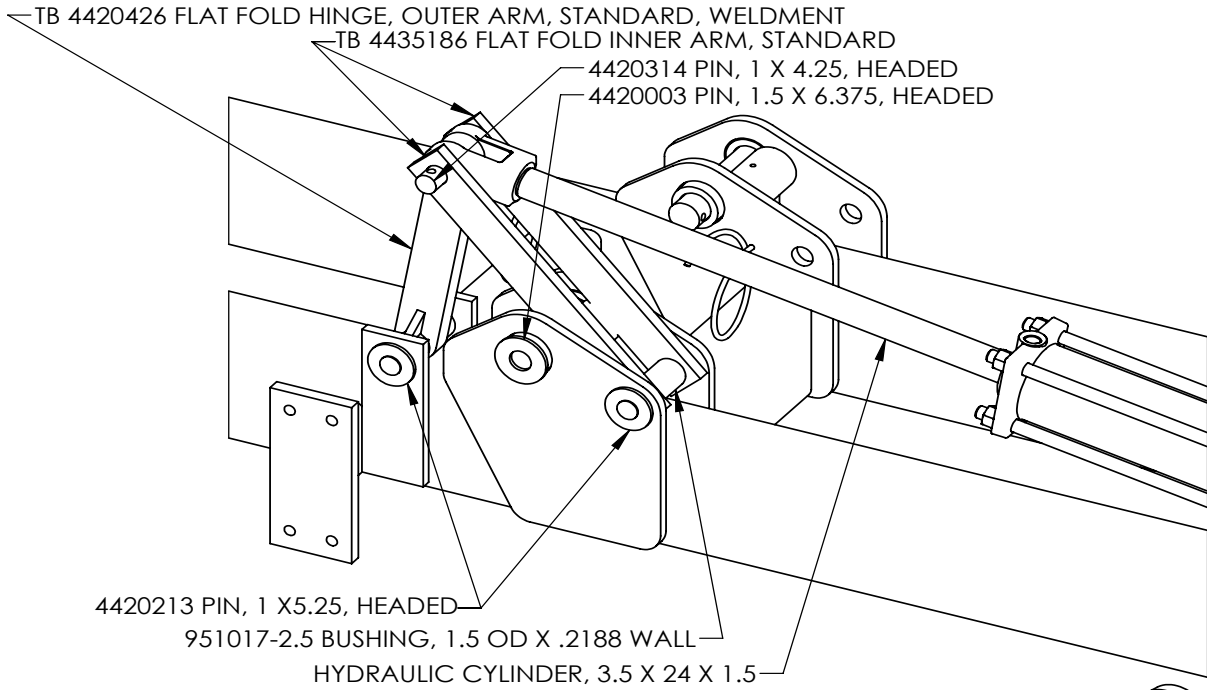

**DLQ DOUBLE LIFT TOOLBAR**

LIFT CYLINDER LINKAGE

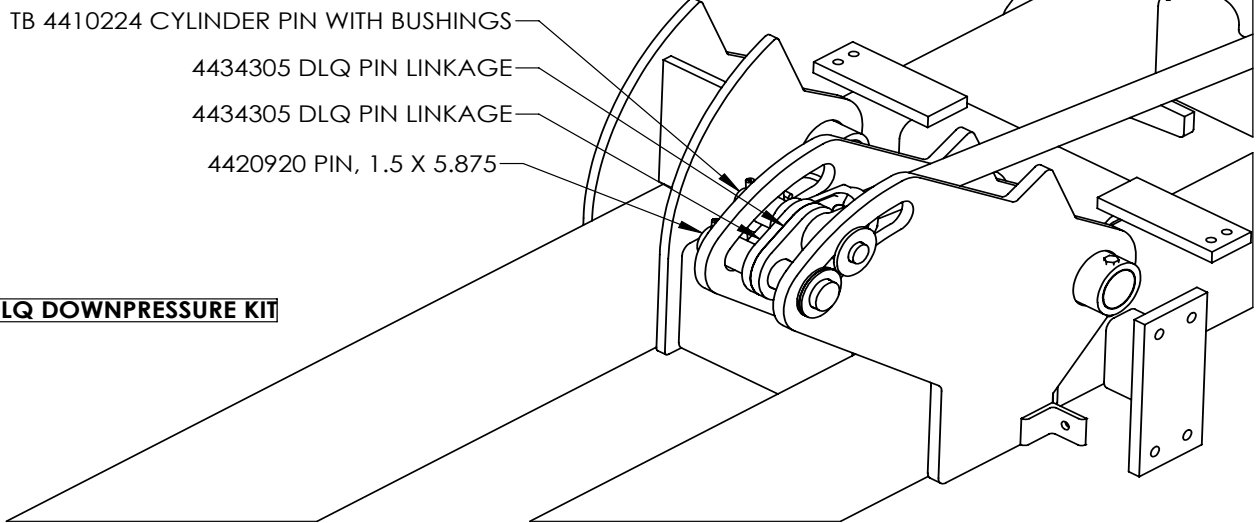

**DLQ DOWNPRESSURE KIT**

DRAWN BY	RICH SMOTHERS	6/12/2015
CHECKED BY		
PRINT DATE	5/19/2017	
CONFIG.	Default	
COMMENTS:		



DWG: CYLINDER LINKAGE AND DOWNPRESSURE

**PROPRIETARY AND CONFIDENTIAL**  
THE INFORMATION CONTAINED IN THIS DRAWING IS THE SOLE PROPERTY OF DALTON AG. ANY REPRODUCTION IN PART OR AS A WHOLE WITHOUT THE WRITTEN PERMISSION OF DALTON AG IS PROHIBITED.

SIZE	SHEET TITLE:	Sheet1	REV
<b>A</b>			<b>A</b>
SCALE: 1:8	SHEET 1 OF 1		

# DLQ WING LOCK

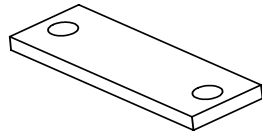

**TB 4435227 BOLT PLATE, WING LOCK HOOK**

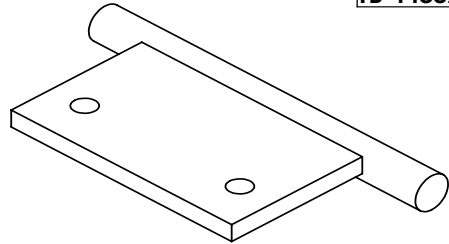

**TB 4420425 WING LOCK HOOK, WELDMENT**

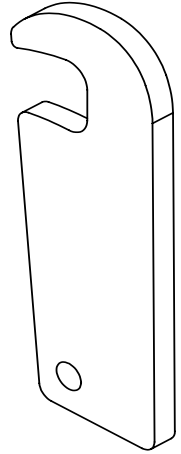

**4435426 WING LATCH**

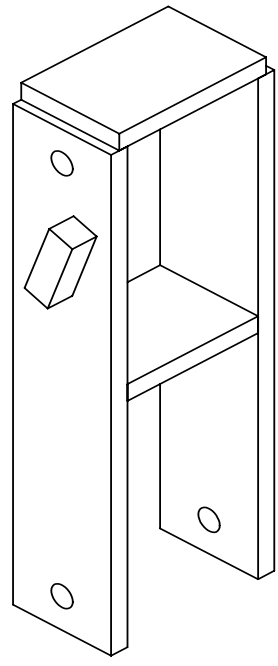

**DLQ 4421028 WING LOCK BASE, WELDMENT**

DRAWN BY	RICH SMOTHERS	1/25/2012
CHECKED BY		
PRINT DATE	6/24/2016	
CONFIG.	RIGHT	
COMMENTS:		



**PROPRIETARY AND CONFIDENTIAL**  
 THE INFORMATION CONTAINED IN THIS DRAWING IS THE SOLE PROPERTY OF DALTON AG. ANY REPRODUCTION IN PART OR AS A WHOLE WITHOUT THE WRITTEN PERMISSION OF DALTON AG IS PROHIBITED.

DWG: DLQ WING LOCK		
SIZE <b>A</b>	SHEET TITLE: Sheet1	REV <b>A</b>
SCALE: 1:4	SHEET 1 OF 1	

## 2 PIN GAUGE WHEEL AND BRACKET

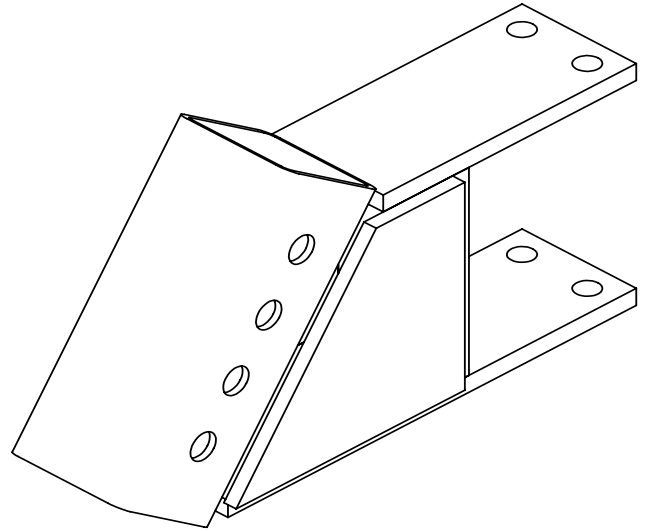
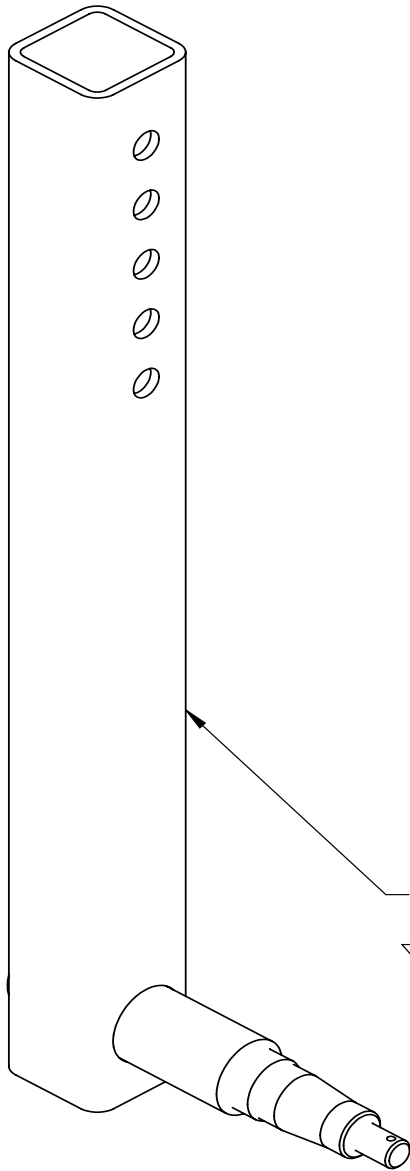

**4420589 2 PIN GAUGE WHEEL BRACKET**

**Hardware:**

- 2 - PULL RING PIN, .75 x 4.5
- 2 - 152422 BOLT, .625 NC x 8, G5
- 2 - 150222 LOCK WASHER, .625, PLTD
- 2 - 150010 NUT, .625 NC, PLTD

**4410271 2 PIN GAUGE WHEEL**

— 4420032 INNER TUBE WELDMENT, 2 PIN GAUGE WHEEL

— 4410086 888 6-BOLT HUB ASSEMBLY, COMPLETE

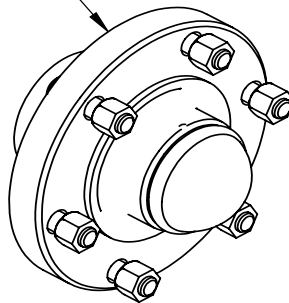

**Optional:**

- 110118 WHEEL, 15 x 8 x 6 BOLT
- 640461 TIRE, 11L x 15 x 8 PLY

DRAWN BY	RICH SMOTHERS	1/21/2014
CHECKED BY		
PRINT DATE	6/21/2016	
CONFIG.	Default	
COMMENTS:		



DWG: 2 PIN GAUGE WHEEL AND BRACKET

SIZE	SHEET TITLE:	Sheet1	REV
<b>A</b>			<b>A</b>
SCALE: 1:4	SHEET 1 OF 1		

**PROPRIETARY AND CONFIDENTIAL**  
 THE INFORMATION CONTAINED IN THIS DRAWING IS THE SOLE PROPERTY OF DALTON AG. ANY REPRODUCTION IN PART OR AS A WHOLE WITHOUT THE WRITTEN PERMISSION OF DALTON AG IS PROHIBITED.



# 4410086, 888 6-BOLT HUB ASSEMBLY, COMPLETE

ASSEMBLY

4410086 888 6-BOLT HUB ASSEMBLY, COMPLETE

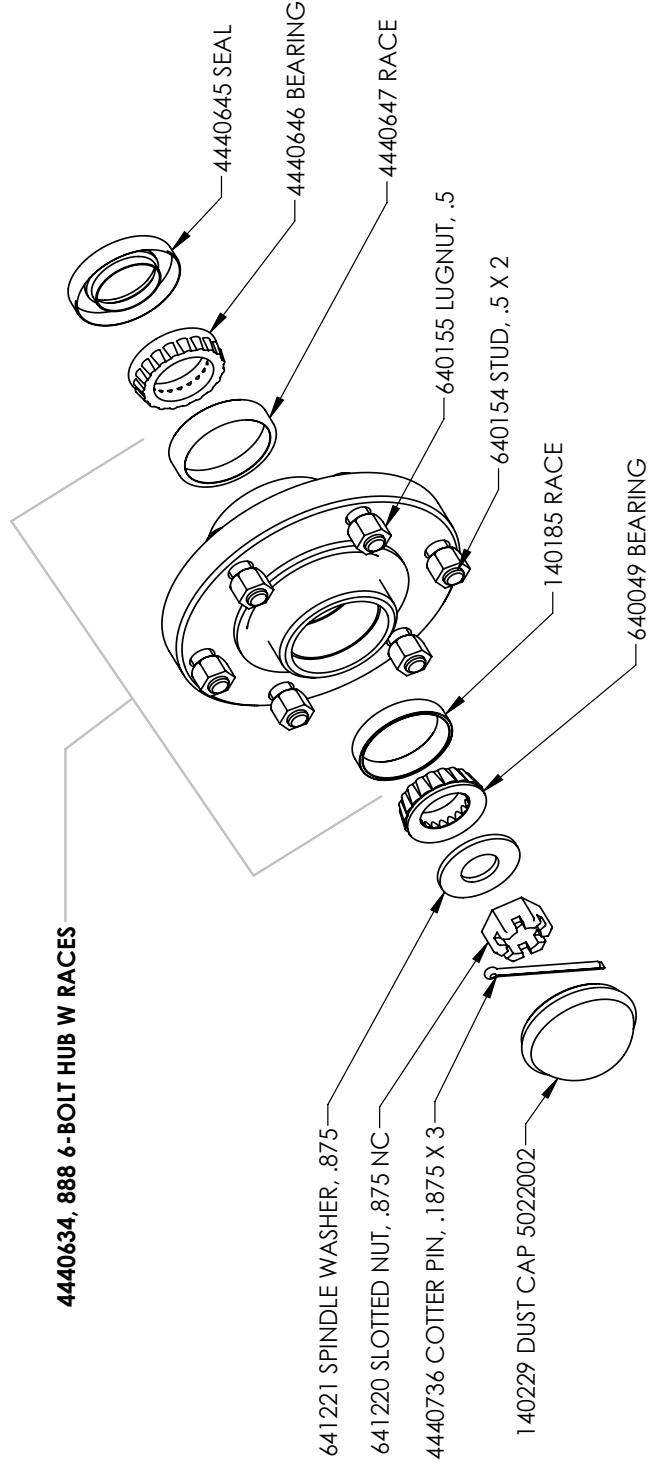

## 4410086 888 6-BOLT HUB ASSEMBLY, COMPLETE

DRAWN BY	RICH SMOTHERS	5/4/2009		
CHECKED BY				
PRINT DATE	12/13/2017			
CONFIG.	EXPLODED			
COMMENTS:	<p><b>PROPRIETARY AND CONFIDENTIAL</b>                  THE INFORMATION CONTAINED IN THIS DRAWING IS THE SOLE PROPERTY OF DALTON AG. ANY REPRODUCTION IN PART OR AS A WHOLE WITHOUT THE WRITTEN PERMISSION OF DALTON AG IS PROHIBITED.</p>			
DWG:	4410086 888 6-BOLT HUB ASSEMBLY, COMPLETE			
SIZE	A	SHEET TITLE:	Sheet1	REV
SCALE:	1:4	SHEET 1 OF 1		A

# GROUND DRIVE ASSEMBLY (LESS PUMP WITH LUG TIRE)

GROUND DRIVE ASSEMBLY, LESS PUMP WITH LUG TIRE

## 4410298 6 INCH MOUNTING BRACKET ASSEMBLY

4434208 6 INCH MOUNTING PLATE, JOHN BLUE  
 152621 BOLT .75 X 6.5 NC GRD 5 PLTD  
 4420294 6 INCH MOUNTING BRACKET, GROUND DRIVE, JOHN BLUE  
 158021 NUT, CENTERLOCK .75

150061 NUT, 1 NC, CENTERLOCK, PLTD  
 4420587 SPRING CUSHION BRACKET  
 4440807 SPRING  
 4420588 TURNBUCKLE, JOHN BLUE

## 641685 PIN .75 x 6 w HITCH CLIP

## 4410310 SPRING CUSHION ASSEMBLY

152602 BOLT .75 X 2.5 NC GRD 5  
 150220 FLAT WASHER, .5 PLTD  
 4440848 COTTER PIN, .3125 X 3  
 4420644 PIN, 1 X 9.625, HEADED  
 640013 50 I 17H-.5 IDLER SPROCKET  
 150220 FLAT WASHER, .5 PLTD  
 152235 BOLT .5 X 2.5 NC GRD 5  
 TIRE 340-510  
 110076 WHEEL, 15X6, 6 BOLT  
 640155 LUGNUT, .5  
 1200107 DRIVE SPROCKET

150008 NUT, .5 NC, PLTD  
 150220 FLAT WASHER, .5 PLTD  
 158021 NUT, CENTERLOCK .75  
 4410295 LOWER WHEEL DRIVE & PUMP  
 MOUNTING BRACKET w HUB  
 4410086 888 6-BOLT HUB ASSEMBLY, COMPLETE  
 4432166-130 STAINLESS #50 CHAIN, 125 PITCH  
 W CONNECTOR (GROUND DRIVE)

## 4410116 GROUND DRIVE ASSEMBLY, LESS PUMP WITH LUG TIRE

DRAWN BY	RICH SMOTHERS	5/21/2014
CHECKED BY		
PRINT DATE	5/19/2017	
CONFIG.	EXPLODED	
COMMENTS:		

**Dalton**  
 USA  
 602 E. VAN BUREN ST., LENOX, IA 50851

DWG: GROUND DRIVE ASSEMBLY, LESS PUMP WITH LUG TIRE

SIZE	A	SHEET TITLE:	Sheet1	REV	A
SCALE:	1:16			SHEET 1 OF 1	

**PROPRIETARY AND CONFIDENTIAL**  
 THE INFORMATION CONTAINED IN THIS DRAWING IS THE SOLE PROPERTY OF DALTON A.G. ANY REPRODUCTION IN PART OR AS A WHOLE WITHOUT THE WRITTEN PERMISSION OF DALTON A.G IS PROHIBITED.

	1	2	3	4	5
--	---	---	---	---	---

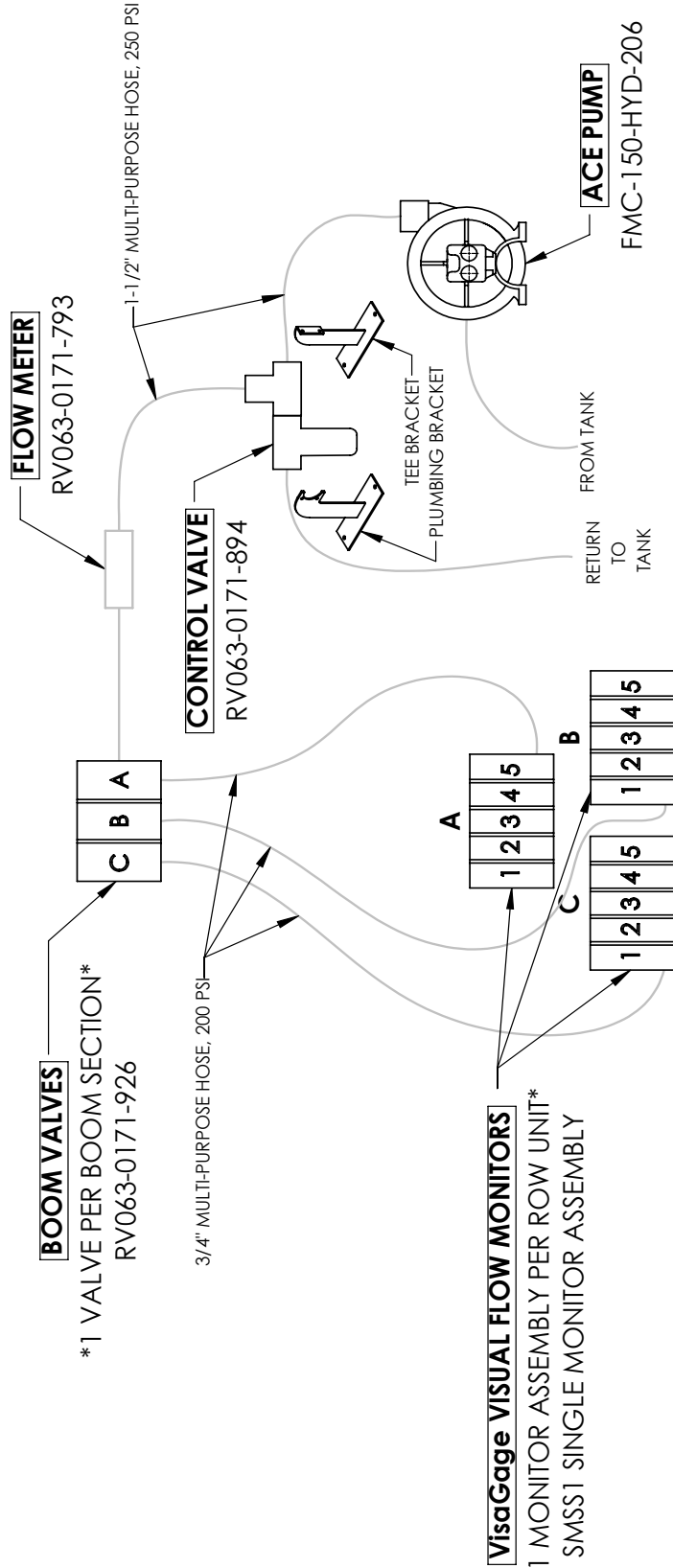

THERMOID 3/8" AG SPRAY HOSE  
TO ROW UNITS

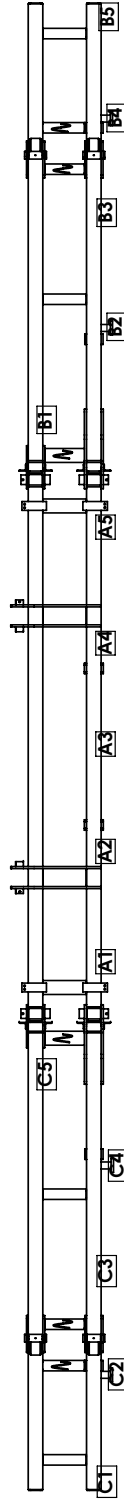

DRAWN BY	RICH SMOTHERS	4/21/2016
CHECKED BY		
PRINT DATE	5/22/2017	
CONFIG.	Default	
COMMENTS:		



DWG: DLQ 3-SHUTOFF RAVEN PLUMBING

**PROPRIETARY AND CONFIDENTIAL**  
THE INFORMATION CONTAINED IN THIS DRAWING IS THE SOLE PROPERTY OF DALTON AG. ANY REPRODUCTION IN PART OR AS A WHOLE WITHOUT THE WRITTEN PERMISSION OF DALTON AG IS PROHIBITED.

SIZE	A	SHEET TITLE:	DLQ 3-SHUTOFF RAVEN PLUMBING	REV	0
SCALE:	1:48	SHEET 1 OF 1			

# YETTER COULTER ASSEMBLY

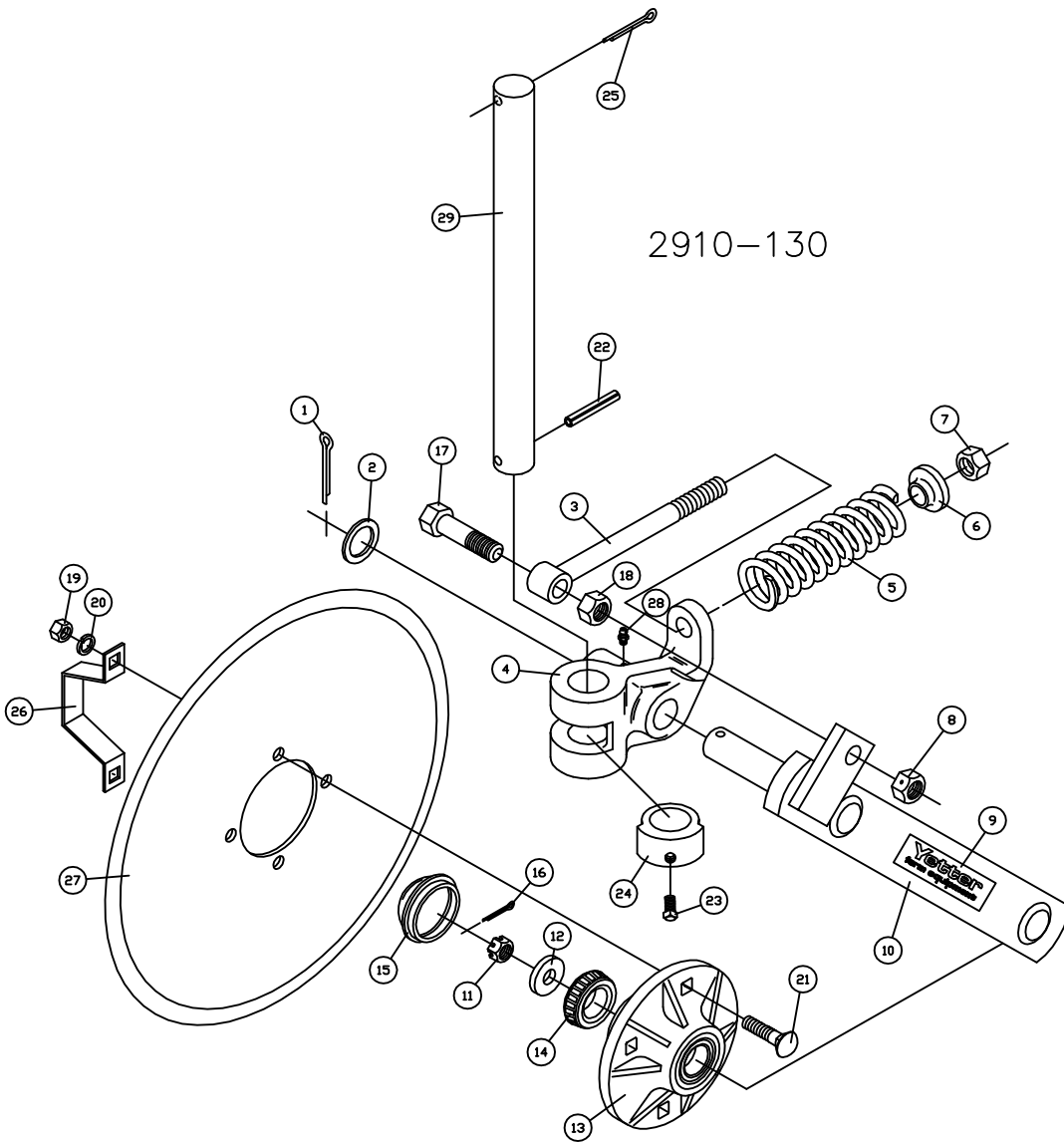

2910-130

DET	QTY	PART NO.	DESCRIPTION	DET	QTY	PART NO.	DESCRIPTION
1	1	2531-125	1/4" X 1-3/4" COTTER PIN	14	1	2550-027	CONE, LM67048
2	1	2526-561	1-17/64"ID X1-7/8"OD X14GA WASHER	15	1	2570-375	DUST CAP
3	1	2570-125	EYEBOLT	16	1	2531-102	1/8" X 1-1/4" COTTER PIN
4	1	2910-320	PIVOT	17	1	2502-410	3/4"-16 X 3" HEX BOLT GRADE 5
5	1	2910-311	SPRING	18	1	2520-508	3/4"-16 HEX NUT
6	1	2910-302	SPRING BUSHING	19	4	2520-352	1/2"-13 HEX NUT
7	1	2520-516	3/4"-10 NY-LOCK HEX NUT	20	4	2525-352	1/2" LOCKWASHER
8	1	2520-511	3/4"-16 LOCK HEX NUT	21	4	2505-337	1/2"-13 X 1 1/4" CARRIAGE BOLT GRADE 5
9	1	2565-162	DECAL-YETTER	22	1	2530-208	3/8" X 2-1/2" ROLL PIN
10	1	2910-201	PIVOT ARM	23	1	2503-379	5/8"-11 X 1" SET SCREW
11	1	2520-469	5/8"-18 SLOTTED HEX NUT	24	1	2910-301	SWIVEL COLLAR
12	1	2526-449	5/8" FLATWASHER, 1/4" THICK	25	1	2531-161	5/16" X 2-1/2" COTTER PIN
13	1	2900-102	HUB SUB-ASSEMBLY	26	1	2987-301	DUST CAP RETAINER
	1	2550-027	CONE, LM67048	27	1		COULTER BLADE-REFERENCE ONLY
	1	2550-066	TRIPLE LIP SEAL	28	1	2533-110	1/4"-28 LUBE FITTING-SELF TAP
	1	2900-105	HUB/CUP PRESSED ASSEMBLY	29	1		SHANK 1-1/2" ROUND-REFERENCE ONLY
	1	2533-110	1/4"-28 LUBE FITTING-SELF TAP				
	1	2550-029	CUP, LM67010				

05/12/2016 S431

# NOZZLE AND COULTER ASSEMBLY

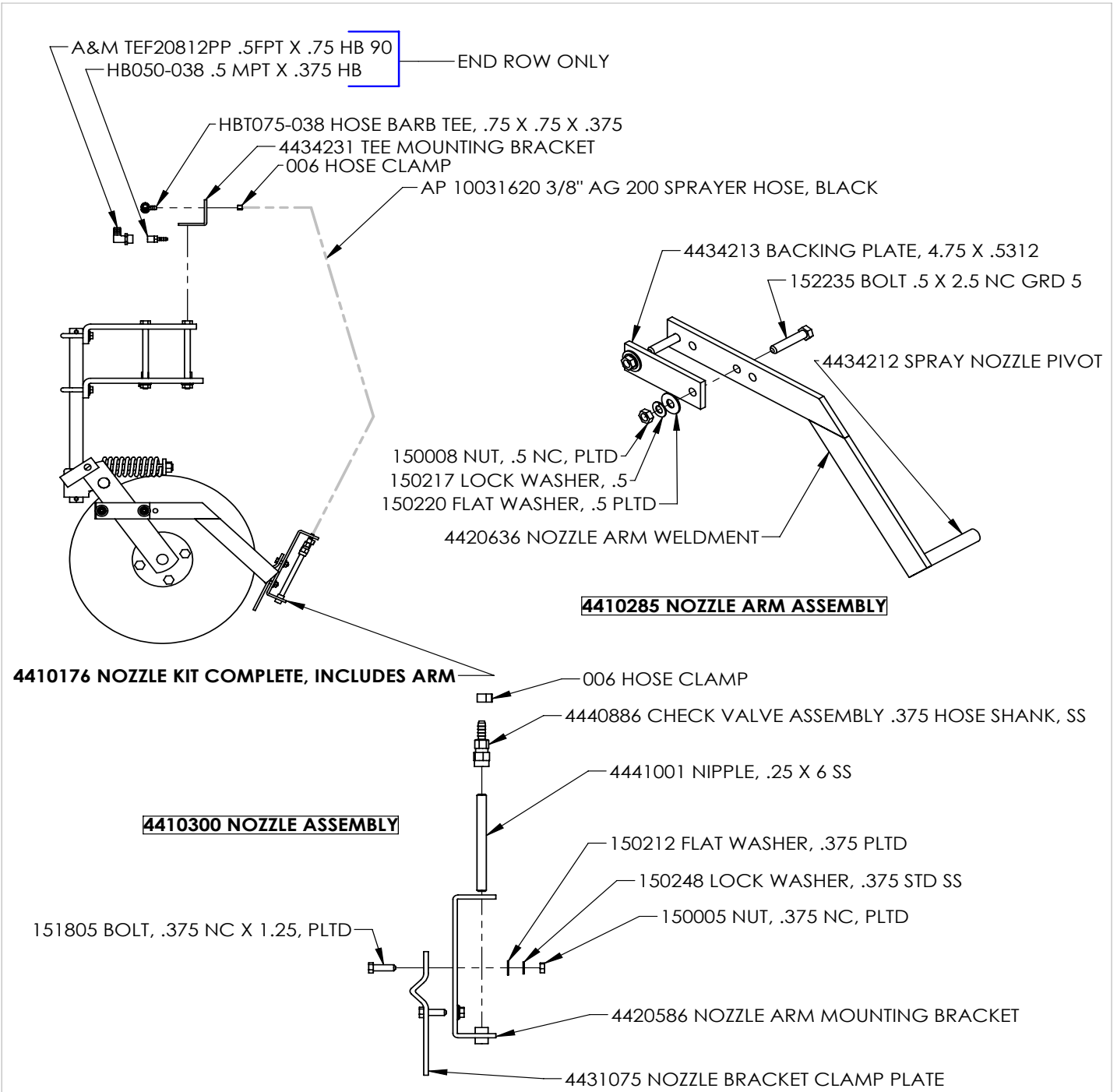

DRAWN BY	RICH SMOTHERS	7/22/2014
CHECKED BY		
PRINT DATE	6/21/2016	
CONFIG.	Default	
COMMENTS:		



**PROPRIETARY AND CONFIDENTIAL**  
 THE INFORMATION CONTAINED IN THIS DRAWING IS THE SOLE PROPERTY OF CMC-DALTON AG. ANY REPRODUCTION IN PART OR AS A WHOLE WITHOUT THE WRITTEN PERMISSION OF CMC-DALTON AG IS PROHIBITED.

DWG: NOZZLE & COULTER ASSEMBLY		
SIZE <b>A</b>	SHEET TITLE: NOZZLE & COULTER ASSEMBLY	REV <b>A</b>
SCALE: 1:16	SHEET 1 OF 1	

# GROVE COULTER ASSEMBLY

## B.O.M FOR COULTER ASSEMBLY

ITEM NO.	PART #	DESCRIPTION	QTY.
1	GC3000	Cast Coultter Knuckle	1
2	GC3005	Nylon Shaft Bushing	2
3	GC3010	Nylon Knuckle Bushing	1
4	GC3105	Lock Collar	1
5	GC4075	5/8-11x1 Sq Hd Set Pt	1
6	GC2005	Coulter Arm	1
7	GC3035	G120 Coulter Hub	1
8	GC5005	Dust Cap Keeper	1
9	GC3070	Spring Rod	1
10	GC3060	Nylon Spring Bushing	1
11	GC3055	Spring Bolt	1
12	GC3065	Spring Nut	2
13	GC3075	Spring	1
14	GC3080	Spring Alignment Casting	1
15	GC3085	Spring Lock Nut	1
16	GC3090	Washer	1
17	G905942	Cotter Pin	1
18	GC3095	Attachment Arm	1
19	GC3102	Knife Bracket	1
20	GC5010	Knife	1
21	GC3205	Injector Mount	1

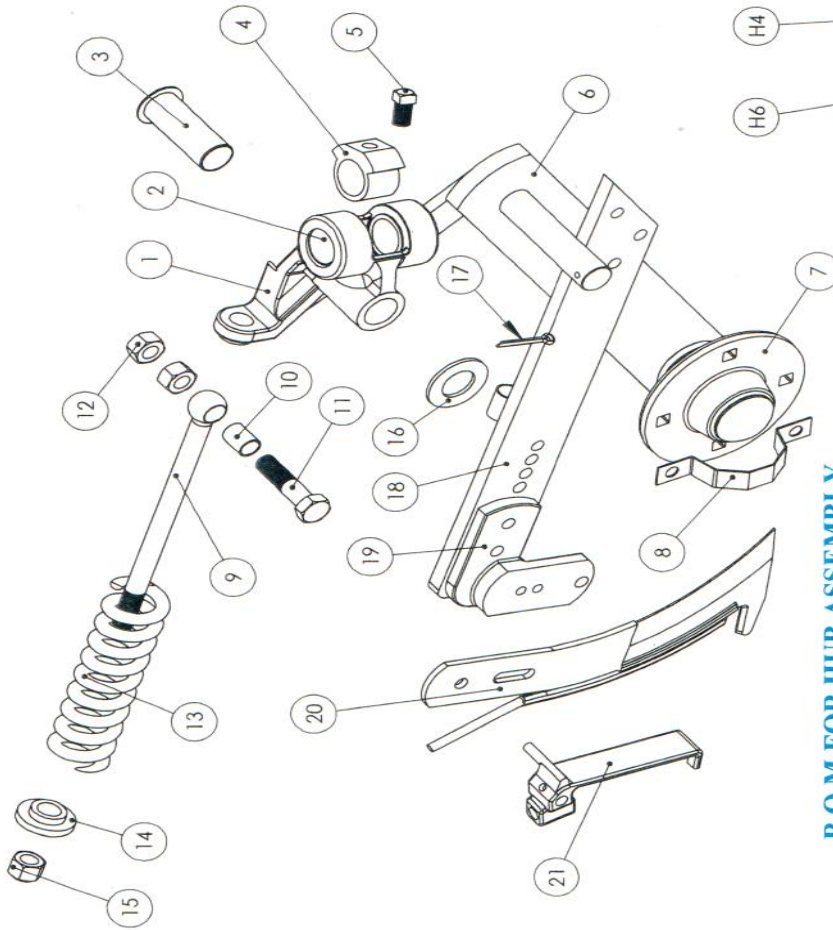

## B.O.M FOR HUB ASSEMBLY

ITEM NO.	PART #	DESCRIPTION	QTY.
H1	GC3035	G120 Coulter Hub	1
H2	G910257	LM67010 Cup	2
H3	G910259	LM67048 Bearing	2
H4	GC3040	Seal Counterface	1
H5	GC3045	Coulter Seal	1
H6	GC3050	Seal Protector	1
H7	GC3020	Coulter Spindle	1
H8	G913611	Washer	1
H9	G912954	Slotted Hex Nut	1
H10	G905936	Cotter Pin	1
H11	G909970	Dust Cap	1

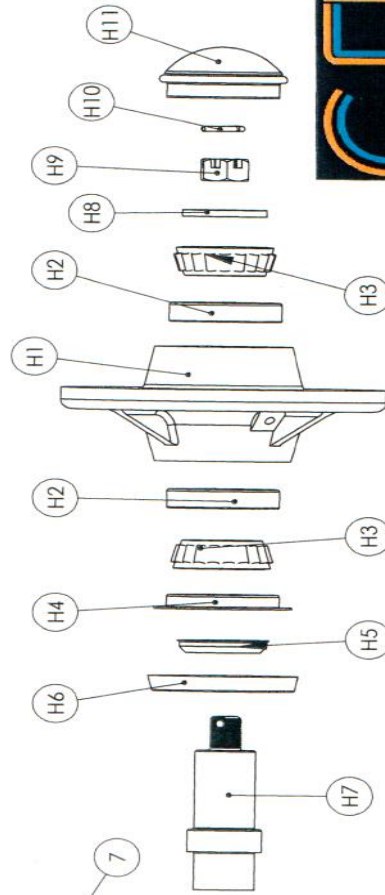

# GROVE KNIFE AND INJECTION

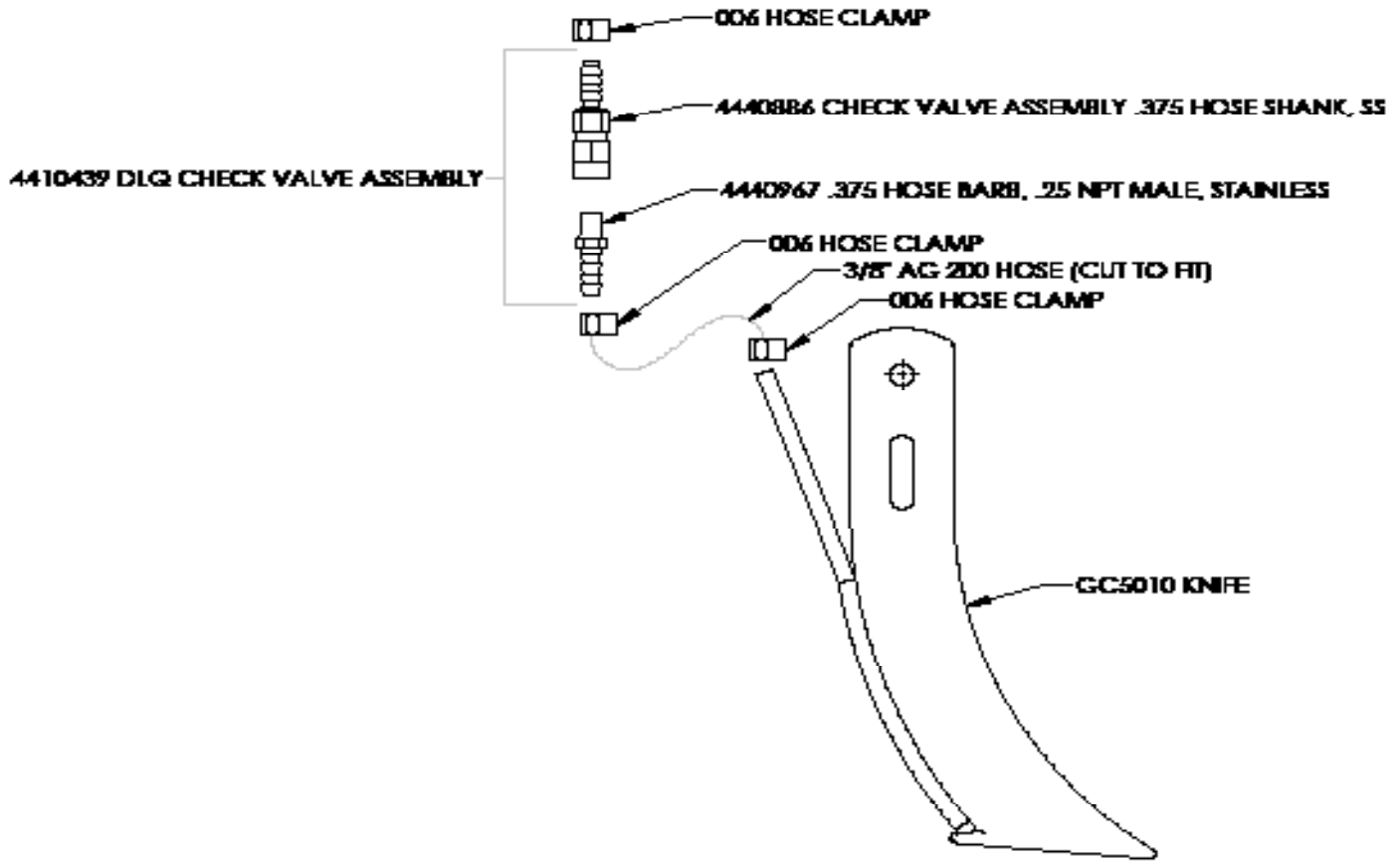

**GROVE KNIFE ASSEMBLY**

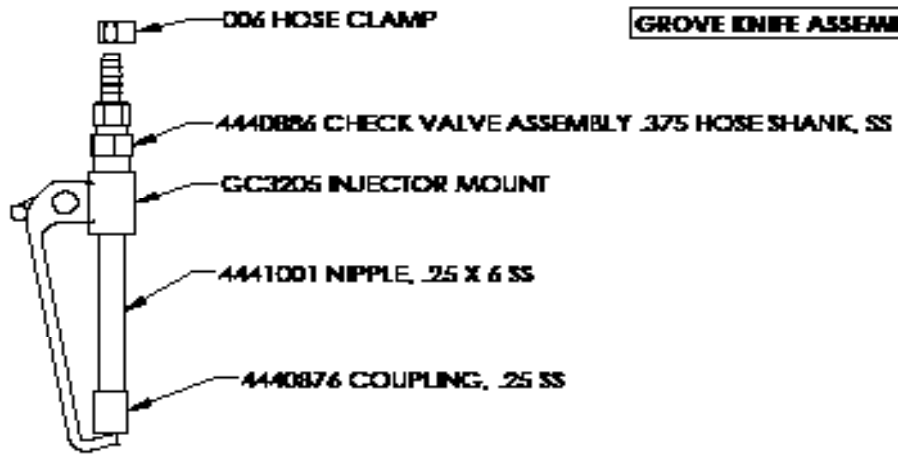

**4410438 GROVE NOZZLE ASSEMBLY**

DRAWN BY	RICH SMOTHERS	6/3/2016
CHECKED BY		
PRINT DATE	4/21/2016	
CONFIG.	Default	
COMMENTS:		



DWG: GROVE KNIFE AND INJECTION			
SIZE	SHEET TITLE	SHEET	REV
A		Sheet 1	A
SCALE 1:1		SHEET 1 OF 1	

PROPRIETARY AND CONFIDENTIAL  
 INFORMATION CONTAINED IN THIS  
 DRAWING IS THE SOLE PROPERTY OF  
 DALTON AG. ANY REPRODUCTION IN  
 PART OR AS A WHOLE WITHOUT THE  
 WRITTEN PERMISSION OF DALTON AG IS  
 PROHIBITED.

# DLQ DOWNPRESSURE KIT - GULL WING PLUMBING

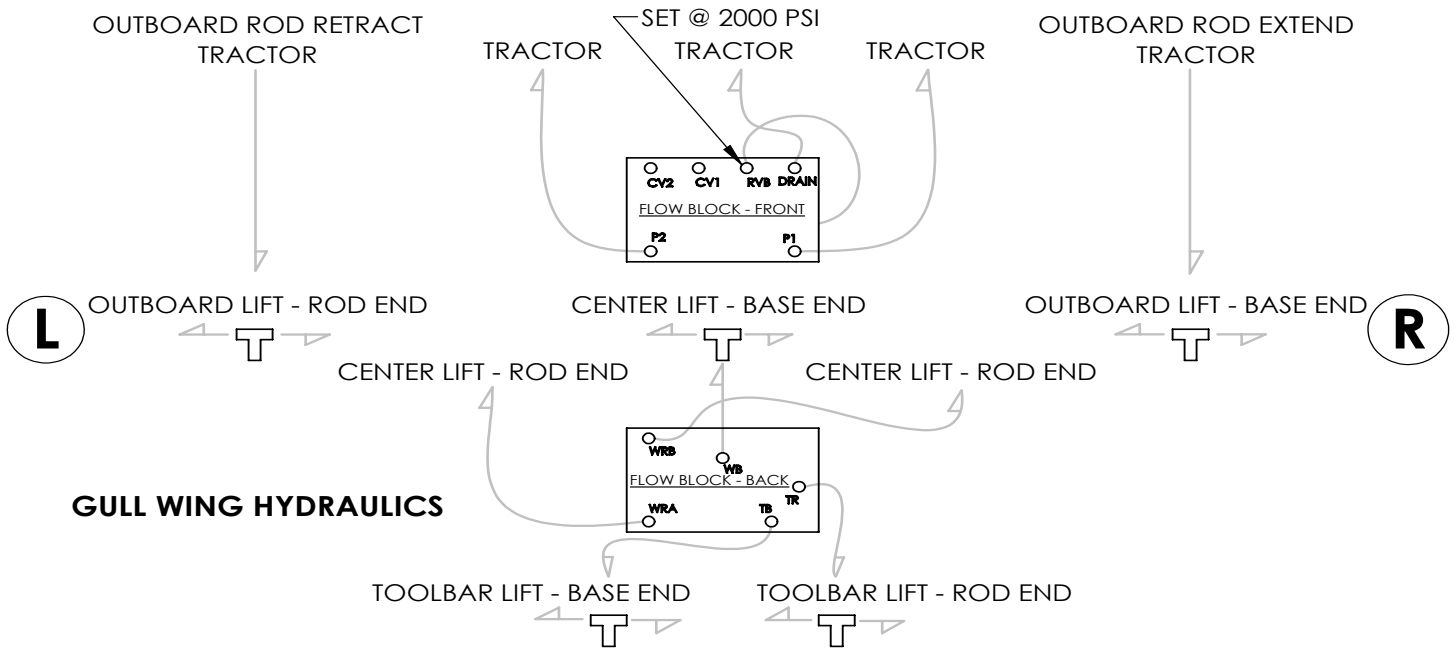
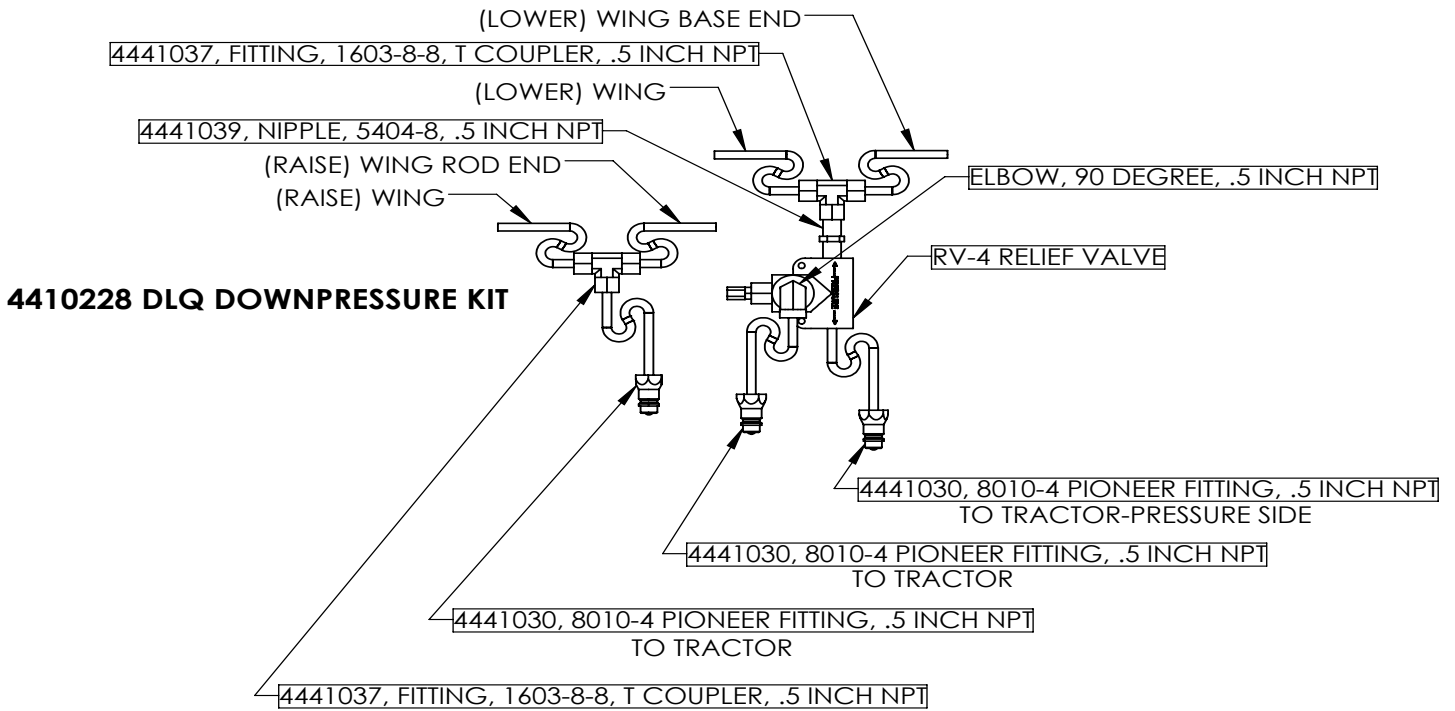

DRAWN BY	RICH SMOTHERS	8/26/2009
CHECKED BY		
PRINT DATE	6/28/2016	
CONFIG.	Default	
COMMENTS:		



**PROPRIETARY AND CONFIDENTIAL**  
 THE INFORMATION CONTAINED IN THIS DRAWING IS THE SOLE PROPERTY OF DALTON AG. ANY REPRODUCTION IN PART OR AS A WHOLE WITHOUT THE WRITTEN PERMISSION OF DALTON AG IS PROHIBITED.

DWG: DLQ DOWNPRESSURE KIT - GULL WING PLUMBING

SIZE	SHEET TITLE:	REV
<b>A</b>	Sheet1	<b>A</b>
SCALE: 1:8	SHEET 1 OF 1	



# DECAL LAYOUT

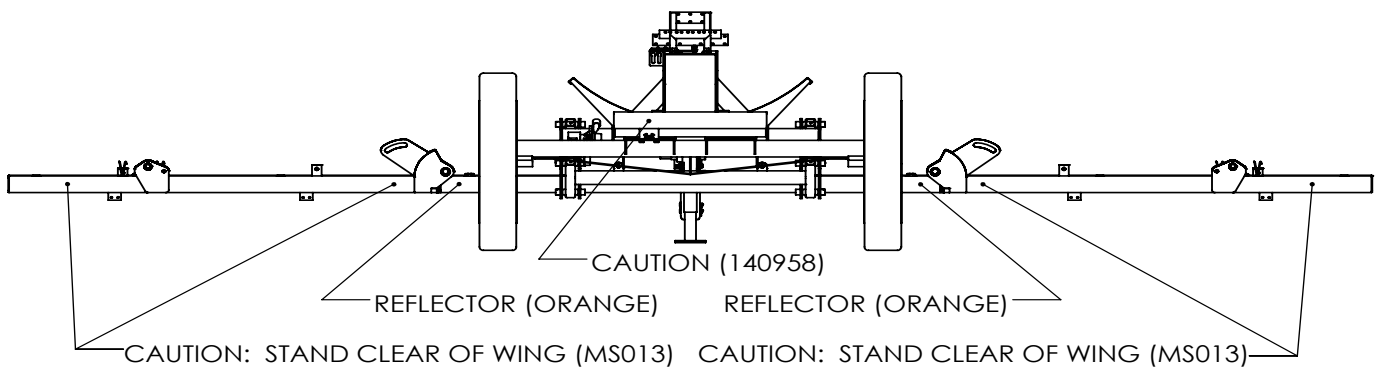
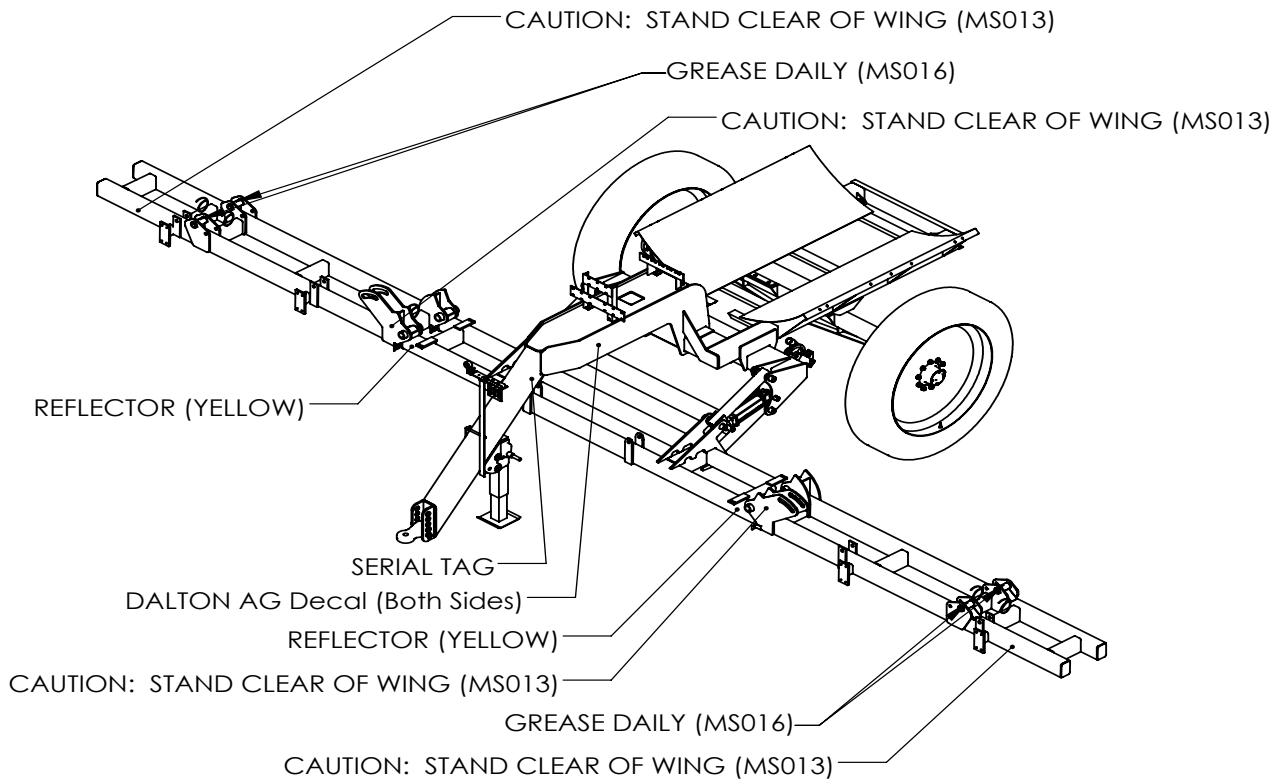

DRAWN BY	RICH SMOTHERS	9/24/2015
CHECKED BY		
PRINT DATE		7/15/2016
CONFIG.	Default	
COMMENTS:		



**PROPRIETARY AND CONFIDENTIAL**  
 THE INFORMATION CONTAINED IN THIS DRAWING IS THE SOLE PROPERTY OF DALTON AG. ANY REPRODUCTION IN PART OR AS A WHOLE WITHOUT THE WRITTEN PERMISSION OF DALTON AG IS PROHIBITED.

DWG: DLQ - DECAL LAYOUT

SIZE	SHEET TITLE:	REV
<b>A</b>	Sheet1	<b>A</b>
SCALE: 1:60	SHEET 1 OF 1	

## PARTS ORDERING PROCEDURE

Your Dalton Ag dealer is interested in your new fertilizer application equipment and has the desire to help you get the most value from it. Through the help of this manual, you will find you can do some of the regular maintenance yourself. For parts and service, contact the Dalton Ag Dealership from which you purchased your fertilizer application equipment or your local Dalton Ag dealer.

When replacement parts are required, consult the applicable illustration and parts list to obtain the correct part name and number. When requesting a replacement part, always include the following information:

1. Complete Part Number
2. Description
3. Quantity Required
4. Machine and Model Number
5. Machine Serial Number - located on the topside of the frame near hitch
6. Provide complete name and address for where and how parts are to be shipped.

NOTE: Right and left hand parts and sides of the units are determined by standing at the rear and facing in the direction of forward travel.

**EQUIPMENT MODEL:** \_\_\_\_\_

**EQUIPMENT SERIAL NO.:** \_\_\_\_\_

**DATE OF PURCHASE:** \_\_\_\_\_

**NAME OF DEALER:** \_\_\_\_\_

**DEALER'S PHONE NUMBER:** \_\_\_\_\_

# Thank you for your business!

**DaltonAg.com**

602 E. Van Buren Lenox, Iowa 50851  
100% Employee Owned

**800.342.7498**

# NOTES

---



[www.daltonag.com](http://www.daltonag.com)

602 E. VAN BUREN / LENOX, IOWA 50851 / 800-342-7498