



OPERATING AND PARTS MANUAL

C-SERIES COMBO SPREADERS

2019



TABLE OF CONTENTS

TO YOU THE OWNER.....	1
LIMITED WARRANTY STATEMENT.....	2
NEW MACHINE CHECKOUT.....	3
OPERATION AND SAFETY.....	4
LUBRICATION SCHEDULE.....	5
LUBRICATION DETAIL	6
BOLT TORQUE CHART.....	7
MACHINE ADJUSTMENT.....	8
SPECIFICATIONS.....	9
SPREAD ADJUSTMENT AND APPLICATION RATES.....	10
STANDARD SPREAD SETUP.....	11
DISTRIBUTOR BLADE TUNING.....	12
FRAME.....	13
C220 HUB AND SPINDLE ASSEMBLY.....	14
C300 & C400 HUB AND SPINDLE ASSEMBLY.....	15
FRONT TANK ASSEMBLY.....	16
REAR AREA ASSEMBLY.....	17
TRACTOR HYDRAULIC DRIVEN SPINNERS.....	18
C-SERIES HYDRAULIC SPINNERS.....	20
VARIABLE RATE CONTROL, ELECTRICAL PLAN.....	21
SPREADER CONSTANT VALUE.....	22
CALIBRATION NUMBERS FOR VARIABLE RATE SPREADERS 180 ENCODER.....	23
CALIBRATION NUMBERS FOR VARIABLE RATE SPREADERS 360 ENCODER.....	24
PARTS ORDERING PROCEDURE.....	25

TO YOU, THE OWNER

Your Dalton Ag Equipment is the most modern, up-to-date, versatile, machine available for fertilizer application. The machine is the result of many years of experience, research, development and testing of equipment for fertilizer application. It is soundly engineered and carefully built to rigid specifications. It is of rugged and simple construction, with a minimum of moving parts.

However, to obtain maximum performance from your Dalton Ag Equipment, it is necessary to follow the instructions and safety suggestions in this manual. Each section has been carefully prepared for the purpose of providing needed and valuable information to the owner and operator. Each operator of this unit should be familiar with the contents of this manual. Keep it in a safe and convenient location. THERE ARE MANY SAFETY SUGGESTIONS (CAUTION AREAS) PRINTED THROUGHOUT THIS MANUAL. CAREFULLY READ THEM ALL BEFORE OPERATING THIS UNIT.

DESIGN IMPROVEMENTS

Dalton Ag Products follows a policy of continuous products improvement. We therefore reserve the right to make design improvements, and changes in specifications and prices, without incurring obligations to make revisions or additions to equipment previously sold.

**REGISTER
WARRANTY
ONE OF
FOUR WAYS**

- Register on-line at:
www.daltonag.com
- Fax your completed warranty registration form to:
641-333-4429
- Email your completed warranty registration form to:
office@daltonag.com
- Mail your completed warranty registration form to:
Dalton Ag, Inc.
P.O. Box 70
Lenox, IA 50851



LIMITED WARRANTY STATEMENT

DALTON AG, INC. warrants to the original purchaser only that all products manufactured under the Dalton Ag and Mobility Brands will be free from defects in material and workmanship under normal use and service.

DALTON AG's obligation under this warranty is limited to repairing or replacing, as it may elect, free of charge and without charge for installation, at the place of business of a dealer or distributor authorized to handle the equipment covered by this warranty or at a DALTON AG facility, any parts that prove, in DALTON AG's judgment, to be defective in material or workmanship within two (2) years after delivery to the original purchaser. DALTON AG shall not be liable for personal injuries or any special or consequential damages of any kind, either direct or indirect. This warranty is subject to acts of God, fire and existing conditions of supply and demand, production, ability or inability to deliver, or for any other valid reason beyond the reasonable control of DALTON AG. No distributor, dealer, agent or DALTON AG employee (other than DALTON's President in writing) is authorized to extend or make any other or further express or implied warranty or incur any additional obligation on DALTON AG's behalf in connection with the sale of this product.

Customer Responsibility

Product Registration - It is a condition of this warranty that the original purchaser fill out the warranty card furnished by DALTON AG and return it to DALTON AG to be recorded in DALTON AG's owner file. Registration may also be done on line at www.DaltonAg.com/warrantyregistration. If the original purchaser's card or electronic registration is not on file at DALTON AG's office, the warranty period will extend only from date equipment was picked up or shipped from the DALTON AG plant.

Maintenance - It is the customer's responsibility to maintain their equipment in accordance with the instructions provided in the Operator's Manual. DALTON AG recommends that you keep records and receipts as the customer may be required to verify the maintenance instructions have been followed.

Operation - It is the customer's responsibility to operate the equipment only for the purpose for which it was designed and in accordance with all safety and operational recommendations contained in the Operator's Manual. If a defect in materials or workmanship occurs, it is the customer's responsibility to cease operating the equipment until authorized repairs are made. Damage incurred from continued operation after a defect is discovered may not be covered by this warranty.

What this Warranty Covers

This warranty covers failures caused by defects in materials or workmanship only.

This Warranty does not cover failures caused by:

- Improper operation
- Natural calamities
- Unauthorized modifications
- Unauthorized repairs
- Use of Non DALTON AG parts
- Neglected maintenance
- Usage contrary to the intended purpose of the product

This Warranty does not cover replacement of Wear or Maintenance Items including, but not limited to:

- Lubricants
- Filters
- Hoses
- Tires
- Disks
- Chains
- Idlers
- Blades
- Belts
- Bearings

This Warranty does not cover:

- Pickup and delivery of the equipment
- Service Calls or Travel Time to and from sites
- Rental of replacement equipment during repair period
- Products that have been declared a total loss and subsequently salvaged
- Overtime labor charges

Parts Warranty

DALTON AG warrants its replacement parts against defects in materials or workmanship for a period of 90 days or the remainder of the product warranty, whichever is longer under the terms set out above. Remedy for defective replacement parts for units that are beyond the original product warranty, will be limited to replacement of the failed part.

DaltonAg.com

602 E. Van Buren Lenoir, Iowa 50851

100% Employee Owned

PHONE: 800.342.7498

FAX: 641.333.4429

NEW MACHINE CHECKOUT

Before attempting to use or operate the spreader it is important to be thoroughly familiarized with the contents of this manual. Then the machine should be checked using the following check list:

1. All bearings lubricated and tightly mounted with collars securely locked.
(See lubrication schedule page 5.)
2. Conveyor chains, drive chain & ground drive chain adjusted to correct tension. Conveyor chain should clear frame members by $\frac{1}{2}$ - $\frac{3}{4}$.
3. Inspect entire machine for loose bolts, especially in the spinner assembly and drive line area.
4. Distributor fan blades set properly. (See spread adjustment and application rates pages 7 through 25.)
5. Setting of metering gate on variable rate. With the pointer on the number 1 of the spread rate chart decal, the lower edge of the metering gate should be 1" above the trough floor or 1/2" above drag chain. This is to set the decal **only**.
6. The metering gate should always be set at 2" or higher.
7. You should always use a gate height as high as possible while still being able to achieve your low rate.
8. Tighten wheel bolts daily – 310 foot pounds single axle spreaders.
9. Check drive line for ease of operation by turning shaft by hand. If the foregoing inspection reveals that additional lubrication or adjustment is required, refer to the proper section of this manual for detailed instructions.

LIME

When spreading lime, move the conveyor shield to the raised position. Next, remove the divider.

OPERATION

SPREADER SAFETY:

Before starting in motion please read the following words of caution.

- A. It is recommended that initial spreading be done in as low a range as possible to permit easy break-in.
- B. Always shut off or disconnect power to spreader before attempting to repair or adjust the spreader.
- C. Do not transport machine with ground drive wheel engaged.
- D. NEVER back-up spreader with ground drive wheel engaged.
- E. Make sure that the towing vehicle brakes are operating properly and are capable of stopping the towing vehicle.
- F. If a pick-up is used as the towing vehicle, it is wise to add ballast for additional safety and traction. We recommend that all towing vehicles be ballast loaded to their recommended G.V.W.
- G. Hitches should be of heavy construction and should be welded or bolted directly to the towing vehicle frame. Hitches should be checked routinely for loose bolts, cracked welds, etc.
- H. Never tow a spreader with a drawbar pin less than 1" in diameter. Pins should also have a locking device.
- I. Do not tow spreader at speeds in excess of 20 mph loaded or 40 mph empty.
- J. Remember, that the stopping and braking distances vary with load and vehicle speed. It is well to familiarize yourself with the characteristics of your machine under different load and speed conditions.
- K. Be sure to attach safety break-away chain and the safety chain to towing vehicle to assure control of spreader in the case of pin or hitch failure.
- L. The unit is designed for hitching to vehicles with drawbar heights between 12 and 18 inches above the ground level. It will operate with all standard tractor hitches and PTO's. WARNING: Hydraulically mounted draw-bars must be securely and mechanically locked because a fully loaded spreader applies a load in the order of 2000 lbs. to the hitch.
- M. WARNING: Remember this unit is designed for agricultural use only and is primarily an off-the-road vehicle and should be towed at tractor speeds ONLY, not to exceed 20 mph loaded or 40 mph empty. Inspect hubs routinely to see if they are heating, which indicates either a need for lubrication or improper adjustment of brakes or bearings, also check stud nuts for tightness.
- N. WARNING: The maximum capacity of this unit is 6 tons (600) or 200 cubic feet, based on a material density of 60 pounds per cubic foot. DO NOT EXCEED THIS LIMIT!

OPERATING INSTRUCTIONS:

Please read the following completely before spreading.

- 1) Attach spreader to towing vehicle, make sure hitch and hitch pin are sound.
- 2) Spinner discs, adjustable chute and conveyor floor should be clean for accurate metering.
- 3) Set metering gate to desired spread rate according to decal on the back end sheet of tank. Always keep the machine in the lowest possible range.

LUBRICATION SCHEDULE

Careful observance of the following lubrication schedule is the best preventative maintenance program for your spreader. We recommend that you establish a firm program to ensure lubrication is in strict compliance with the following schedule. Use only good grade pressure gun type grease unless otherwise specified.

DAILY LUBRICATION SCHEDULE	CONVEYOR DRIVE	ALL MODELS	(6) BEARINGS
-----------------------------------	-----------------------	------------	--------------

WEEKLY LUBRICATION SCHEDULE	CHAINS	OIL	LUBRICATE PIN JOINTS WITH SAE 80-90
------------------------------------	---------------	-----	--

ANNUAL LUBRICATION SCHEDULE	WHEEL BEARINGS	REPACK	
------------------------------------	-----------------------	--------	--

MAINTENANCE SCHEDULE

WEEKLY	WASH SPREADER
	CORRECT BELT TENSION
	ADJUST TENSION OF CONVEYOUR (SEE MACHINE CHECKOUT)

SEMI-ANNUALLY	TIGHTEN LOOSE BOLTS
	REPLACE WORN OR FAILED PARTS
	TOUCH-UP PAINT

LUBRICATION DETAIL

LUBRICATION SCHEDULE		
1	BALL BEARING	EVERY 15 HRS
2	WHEEL BEARING	TWICE A YEAR

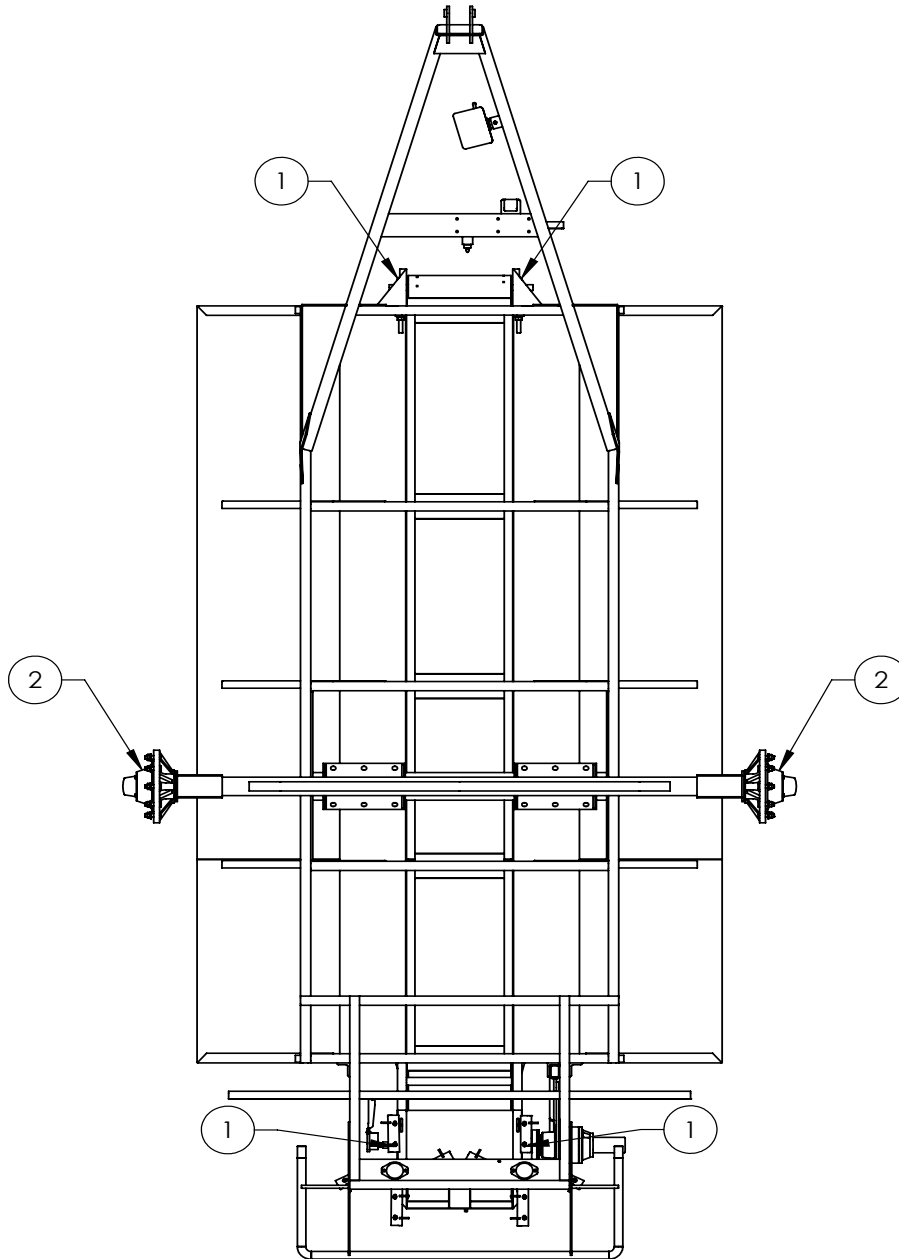

DRAWN BY	RICH SMOTHERS	4/23/2015
CHECKED BY		
PRINT DATE	11/2/2015	
CONFIG.	4400183 400 COMBO SPREADER	
COMMENTS:		







DWG: LUBRICATION SCHEDULE		
SIZE A	SHEET TITLE: Sheet1	REV A
SCALE: 1:36	SHEET 1 OF 1	

PROPRIETARY AND CONFIDENTIAL
THE INFORMATION CONTAINED IN THIS DRAWING IS THE SOLE PROPERTY OF DALTON AG. ANY REPRODUCTION IN PART OR AS A WHOLE WITHOUT THE WRITTEN PERMISSION OF DALTON AG IS PROHIBITED.

FOR PARTS, CALL 1.800.342.7498

IMPORTANT : Over tightening hardware can be as damaging as under tightening. Tightening beyond recommended torque will reduce the fastener's shock load capacity.

BOLT TORQUE CHART

SIZE	 SAE GRADE 2		 SAE GRADE 5		 SAE GRADE 8		 L9
	ASSEMBLY TORQUE DRY	LUBRICATED	ASSEMBLY TORQUE DRY	LUBRICATED	ASSEMBLY TORQUE DRY	LUBRICATED	ASSEMBLY TORQUE LUBRICATED
1/4-20	66*	49*	8	75*	12	9	11
1/4-28	76*	56*	10	86*	14	10	13
5/16-18	11	8	17	13	20	18	21
5/16-24	12	9	19	14	25	20	23
3/8-16	20	15	30	23	45	30	33
3/8-24	23	17	35	25	50	35	38
7/16-14	30	24	50	35	70	55	60
7/16-20	35	25	55	40	80	60	65
1/2-13	50	35	75	55	110	80	95
1/2-20	55	40	90	65	120	90	105
9/16-12	65	50	110	80	150	110	140
9/16-18	75	55	120	90	170	130	150
5/8-11	90	70	150	110	220	170	185
5/8-18	100	80	180	130	240	180	205
3/4-10	160	120	260	200	380	280	290
3/4-16	180	140	300	220	420	320	355
7/8-9	190	140	400	300	600	460	505
7/8-14	210	155	440	320	660	500	585
1-8	220	160	580	440	900	680	775
1-14	240	170	640	480	1000	740	900
1 1/8-7	300	220	800	600	1280	960	1150
1 1/8-12	340	260	880	660	1440	1080	1325
1 1/4-7	420	320	1120	840	1820	1360	1600
1 1/4-12	460	360	1240	920	2000	1500	1750
1 3/8-6	560	420	1460	1100	2380	1780	---
1 3/8-12	640	460	1680	1260	2720	2040	---
1 1/2-6	740	560	1940	1460	3160	2360	3250
1 1/2-12	840	620	2200	1640	3560	2660	3650

**ITEMS WITH * = INCH POUNDS
ALL OTHERS = FOOT POUNDS**

WARNING: Never work around any raised implement while in the raised position without using safety lockups.

MACHINE ADJUSTMENT

WHEEL BEARING ADJUSTMENT

After repacking or when inspecting wheel bearings, the following adjustment procedure should be followed. Place flat washer and spindle nut on spindle. Turn hub as you tighten nut. When a pronounced drag is felt in the bearings, back off nut one complete slot. If necessary continue to back off the nut until the next slot aligns with the cotter pin hole and install cotter pin and dust cap.

CONVEYOR CHAIN ADJUSTMENT

Loosen chain take-up locking nuts on outside of front end of trough. Adjust take-up bolts evenly until chain clears main frame members and axle tube by $\frac{3}{4}$ " $\frac{1}{2}$ ". Inspect shaft bearing mounting bolts and shaft locking collars for tightness of set screws (6 places). Reset take-up locking nuts.

STORAGE

Before storing the spreader for more than a few days, the machine should be emptied completely and thoroughly washed both inside and out. This precaution will minimize the severity of fertilizer acid corrosion, extend the useful life of the machine, and prevent damage to drive line and conveyor chain from fertilizer compaction and caking. We further recommend that the machine be thoroughly greased after washing.

Before operating the machine after extended periods of storage, re-lubricate the entire spreader in accordance with the lubrication section of this manual. Also check the entire spreader, following the New Machine Checkout Procedure to be found in a foregoing section of the manual.

Remember that oil and grease are your least expensive corrosion inhibitors.

ADDITIONAL INSTRUCTIONS:

CAUTION

Do not operate your spreader with less than one and a half (1 1/2) inch of metering gate opening as material will compact against metering gate and cause failure of the conveyor chain.

CAUTION

Do not disconnect implement from tractor with material remaining in box.

SPECIFICATIONS

FEATURES	C220	C300	C400
Capacity (volume)	220 Cu. Ft.	300 Cu. Ft.	400 Cu. Ft.
Capacity (weight)	10 tons	12 tons	12 tons
Overall length	239"	268"	270"
Overall width	102"	147.5"	154.5"
Overall height	99"	108"	119"
Hopper length	120"	120"	164"
Hopper width	93"	102"	102"
Construction - hopper	409 SS	409 SS	409 SS
Construction - frame	8x2 rect. Tube	8x2 rect. Tube	8x2 rect. Tube
Metering gate	Adjustable	Adjustable	Adjustable
Axle(s)	Tandem	Single	Single
Wheels	22.5x13.5	30.5x28	25x36
Tires	Used 425/65R 22.5	850/50R30.5	66x4300R25
Braking system	N/A	N/A	N/A
Conveyor	20" SS Mesh	20" SS Mesh	20" SS Mesh
Conveyor drive	Hydraulic	Hydraulic	Hydraulic
Conveyor rate	Variable	Variable	Variable
Spinners	24"	24"	24"
Spinner drive	Hydraulic	Hydraulic	Hydraulic
Spread coverage	80" Fertilizer	80' Fertilizer	80' Fertilizer
Control system	Raven	Raven	Raven
Bull Pull Hitch	Optional	Standard	Standard
Jack	12K	12K	12K
Tractor hydraulic system req.	28 GPM	28 GPM	28 GPM
Lighting	Optional	Optional	Optional
Scale system	N/A	Optional	Optional
Roll Tarp	Optional	Standard	Standard
Standard colors	White	White	White

CAUTION

1. Keep all shields in place.
2. Stop engine before leaving operator's position to adjust, lubricate, clean, or unclog machines.
3. Wait for all movement to stop before servicing the machine.
4. Keep hands, feet and clothing away from power driven parts.
5. Keep off equipment unless seat or platform for operation or observation is provided.
6. Make certain everyone is clear of machine before starting.

PART No. 140959

SPREAD ADJUSTMENT AND APPLICATION RATES

For accurate and precise spreading rates, it is necessary that you know the weight in pounds per cubic foot of the material to be spread. If this is not known, the weight can be quickly and accurately determined by the following method:

1. Weigh an empty one gallon container.
2. Fill level full with the material to be used.
3. Weigh container and material, and then subtract the weight of the container to obtain the weight of the material.
4. Multiply the weight of the material by 7.5 to obtain the weight of the material in pounds per cubic foot.

Example: Typical Material-Potash

1) Weight of empty one gallon container	1.00 lbs.
2) Weight of filled container	10.35 lbs.
3) Weight of container (net)	9.35 lbs.
4) 9.35×7.5	70.125 lbs. /cu ft.

You would therefore use the column on the Spread Chart headed 70 to determine the proper gate opening for the desired application rate.

Your Mobility Spreader with its heavy-duty distributor discs and blades will apply most materials in a 50 foot wide swath.

STANDARD SPREAD SETUP

STANDARD SPREAD SETUP

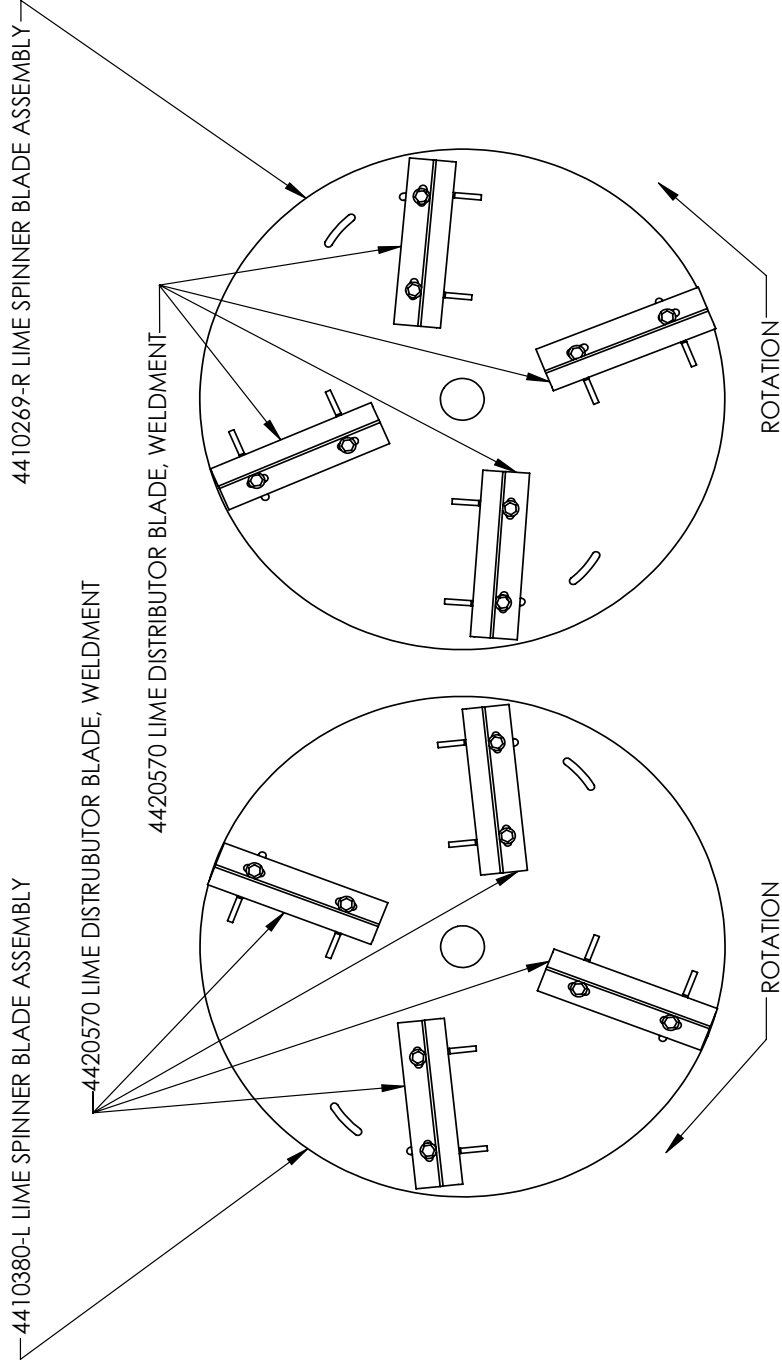

VIEWED FROM BACK OF SPREADER

DRAWN BY	RICH SMOTHERS	11/17/2015	 602 E. VAN BUREN ST., LENOX, IA 50851	
CHECKED BY				
PRINT DATE		11/17/2015	DWG:	STANDARD SPREAD SETUP
CONFIG.	Default		SIZE	A
COMMENTS:			SHEET TITLE:	Sheet1
PROPRIETARY AND CONFIDENTIAL THE INFORMATION CONTAINED IN THIS DRAWING IS THE SOLE PROPERTY OF DALTON A.G. ANY REPRODUCTION IN PART OR AS A WHOLE WITHOUT THE WRITTEN PERMISSION OF DALTON A.G. IS PROHIBITED.			REV	A
			SCALE: 1:8	SHEET 1 OF 1

FOR PARTS, CALL 1.800.342.7498

5

4

3

2

1

DISTRIBUTOR BLADE TUNING

FINE TUNING OF DISTRIBUTOR AND BLADE SETTINGS

All Mobility Spreaders are given an average standard factory setting of distributor blades. Such a setting, of course, cannot be perfect for all field conditions and materials. The following information will be helpful in adjusting the distributor blades on your machine to give optimum performance for your specific conditions.

Your spread pattern will be affected by 1) the material used, 2) the distributor blade setting, and 3) the rotation speed of the distributors. The distributors are designed to be operated at 750 RPM (540 tractor P.T.O. RPM). A plus or minus 10% change in distributor RPM will increase or decrease spread pattern width accordingly. An increase in PTO RPM will tend to deposit less material at the center of the spread pattern, while a decrease will deposit more material at the center. The physical characteristics of the materials being spread, which are important to the spread pattern, include bulk density, particle size, particle shape, physical strength and rugosity or surface roughness. For best performance it is recommended that you fine tune your machine to the material being used. The spreading profile and spread swath width can be changed drastically by alteration of the setting of the distributor blades. The drawing on the next page shows how blades may be extended from or retracted toward the center of the disc. Also, the angle of blade intersection with a radius of the disc may be altered. They may be advanced toward coincidence with the disc radius or retarded away from it. Further, blade lengths are not all equal. These adjustments affect the spread pattern in the following ways:

1. Advance long blades--more material to the outside of spread pattern; also will increase spread pattern width.
2. Retard long blades--opposite effect of above.
3. Advance short blades—helps eliminate problem of streaking in the middle of spread pattern.
4. Retard short blades—puts more material in the center of spread pattern.
5. Extend blades away from center of spinner—increases spread width somewhat.
6. Retract blades (more towards center of spinner)—opposite effect of above.
7. Moving flow divider (or chute) toward the front of spreader will tend to put more material in center of spread pattern. This is because material is deposited on outer edge of spinner causing it to leave earlier.
8. Moving divider toward the rear of the spreader has the opposite effect.

DISTRIBUTOR BLADE TUNING

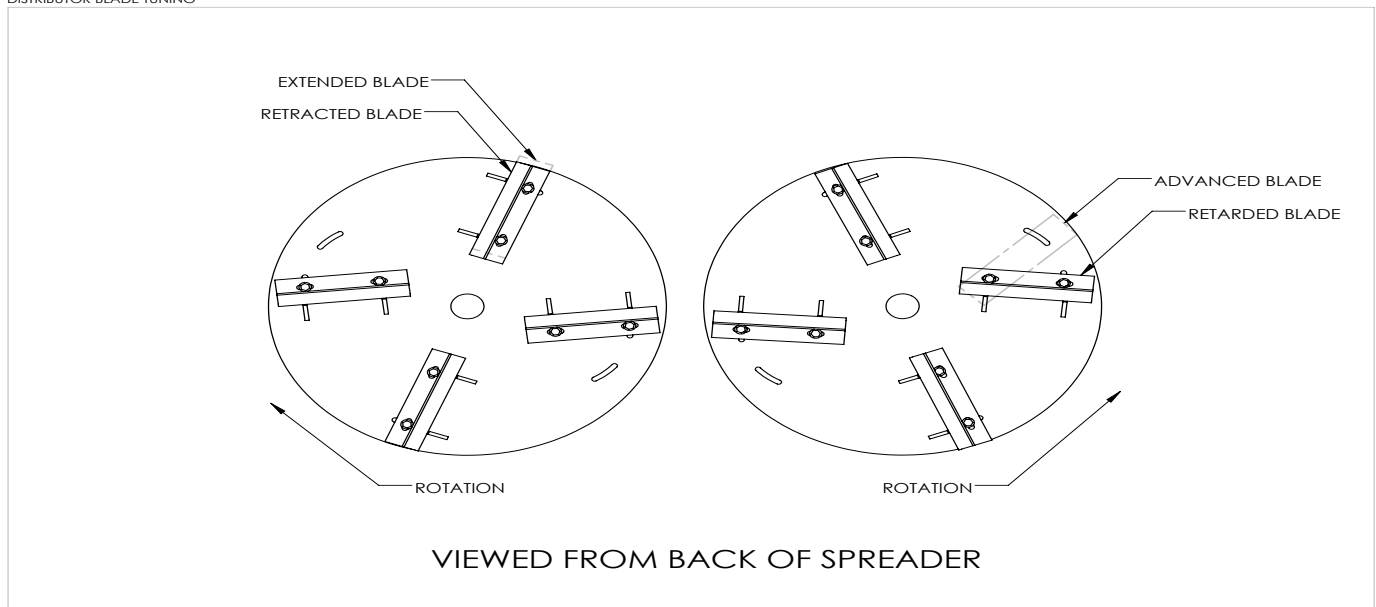

COMBO SPREADER FRAME

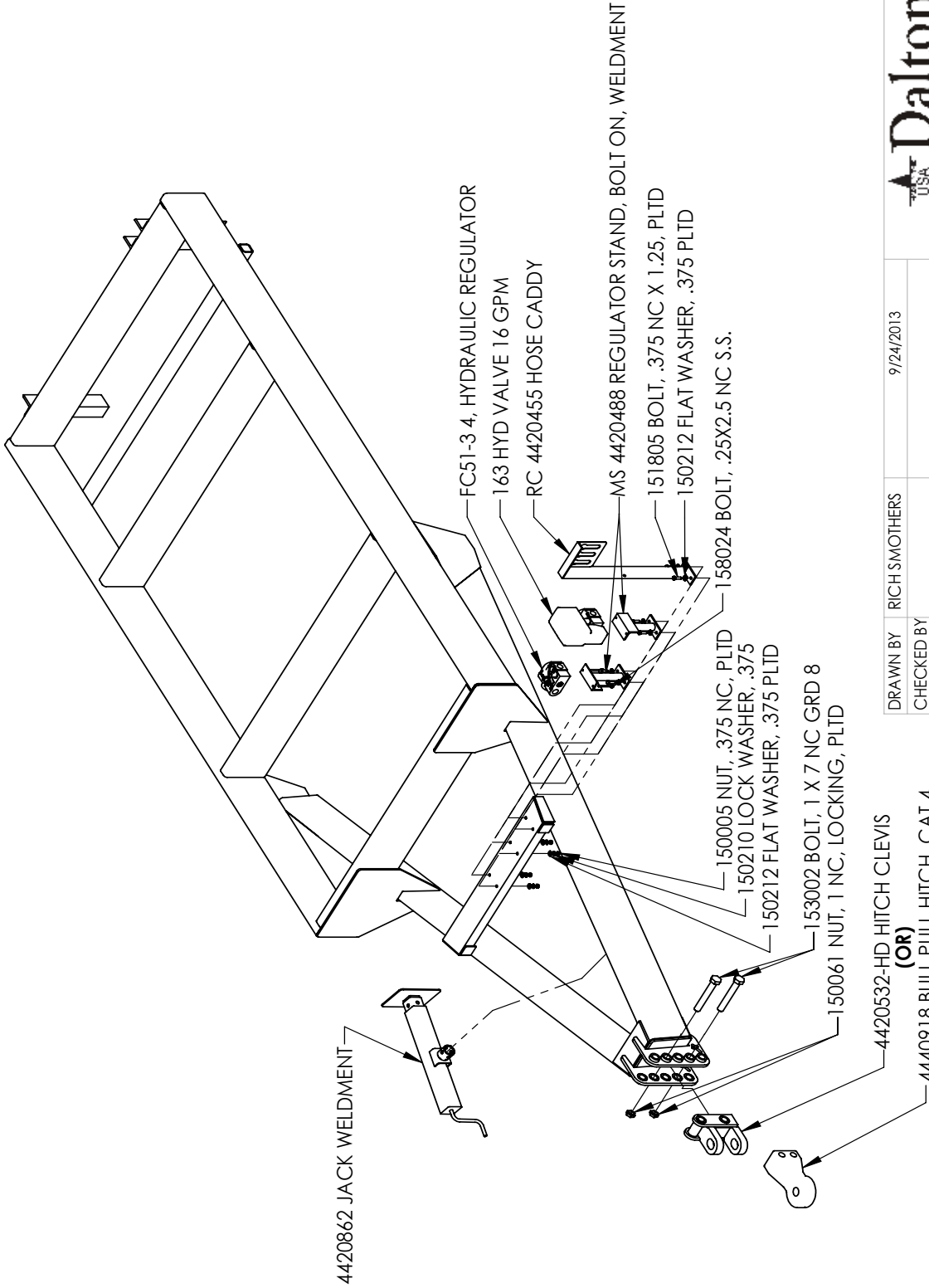

AVAILABLE:
610500 SAFETY CHAIN, PAIR

DRAWN BY	RICH SMOTHERS	9/24/2013	 602 E. VAN BUREN ST., LENOX, IA 50851	
CHECKED BY				
PRINT DATE	11/2/2015		DWG: COMBO SPREADER FRAME	
CONFIG.	4400181 220 COMBO SPREADER		SIZE	A
COMMENTS:	PROPRIETARY AND CONFIDENTIAL THE INFORMATION CONTAINED IN THIS DRAWING IS THE SOLE PROPERTY OF DALTON AG. ANY REPRODUCTION IN PART OR AS A WHOLE WITHOUT THE WRITTEN PERMISSION OF DALTON AG IS PROHIBITED.			
FOR PARTS, CALL 1.800.342.7498			SHEET TITLE:	Sheet
			SCALE:	1:24
			REV	A
			SHEET 1 OF 1	

C220 HUB AND SPINDLE ASSEMBLY

4410244-A, LH and 4410245-A, RH TANDEM WALKERS, LESS BRAKES w HUBS

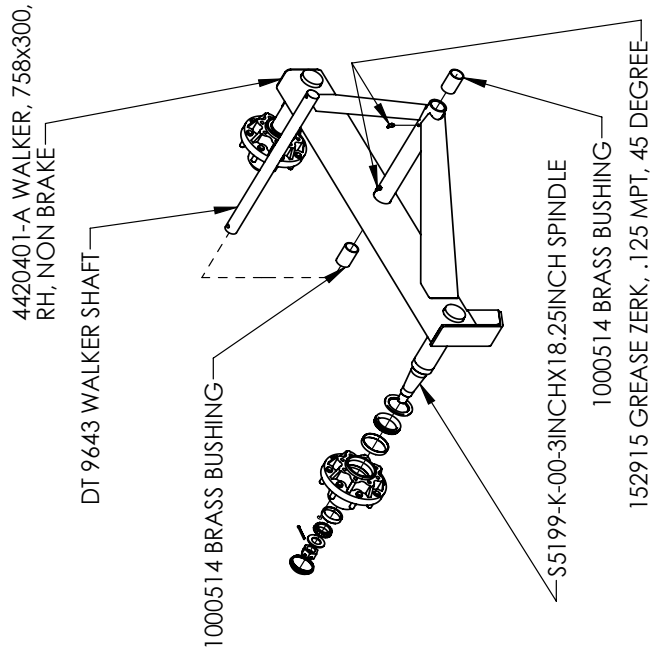

2001113, 758 8 BOLT HUB ASSEMBLY

4410245-A TANDEM WALKER, RH, LESS BRAKES w HUBS

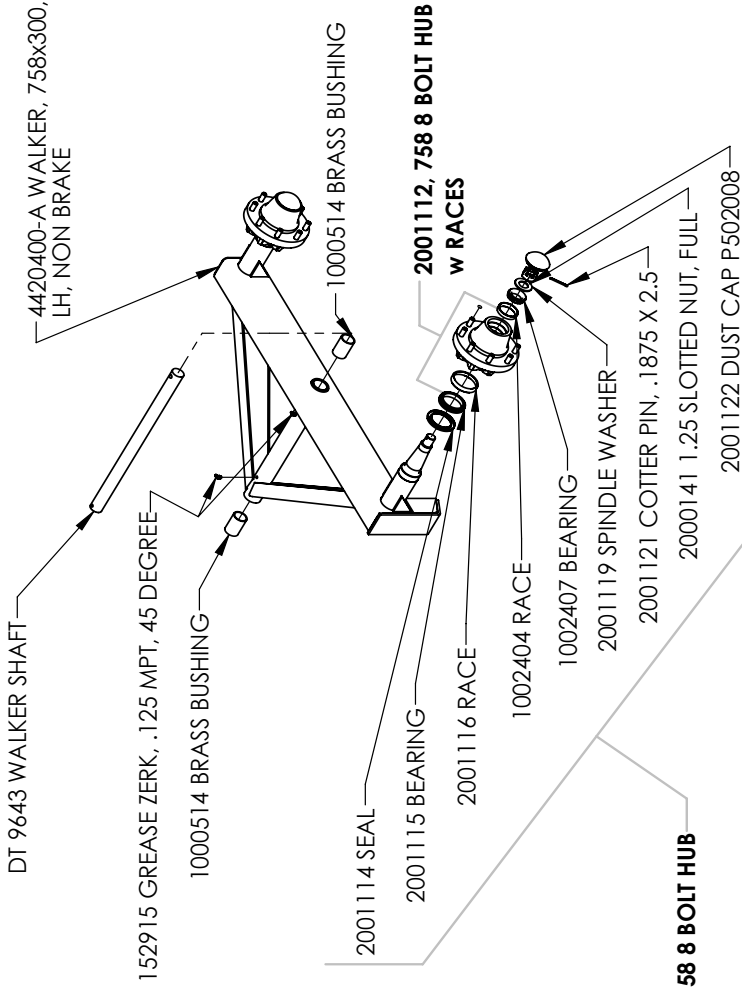

4410244-A TANDEM WALKER, LH, LESS BRAKES w HUBS

641022 LUG NUT, .5625 NC
641024 LUG BOLT, .5625 NC

<p>USA Dalton A G P R O D U C T S 602 E. VAN BUREN ST., LENOX, IA 50851</p>	<p>11/26/2013</p>	<p>RICH SMOTHERS</p>	<p>11/26/2013</p>	<p>1</p>
<p>DRAWN BY</p>	<p>CHECKED BY</p>	<p>PRINT DATE</p>	<p>4/8/2016</p>	<p>2</p>
<p>CONFIG.</p>	<p>4410244-A TANDEM WALKER, LH, LESS BRAKES w HUBS</p>	<p>COMMENTS:</p>	<p>DWG:</p>	<p>4410244-A, LH and 4410245-A, RH TANDEM WALKERS, LESS BRAKES w HUBS</p>
<p>PROPRIETARY AND CONFIDENTIAL THE INFORMATION CONTAINED IN THIS DRAWING IS THE SOLE PROPERTY OF DALTON A.G. ANY REPRODUCTION IN PART OR AS A WHOLE WITHOUT THE WRITTEN PERMISSION OF DALTON A.G IS PROHIBITED.</p>	<p>SIZE</p>	<p>SHEET TITLE:</p>	<p>Sheet1</p>	<p>REV</p>
<p>A</p>	<p>A</p>	<p>SCALE: 1:24</p>	<p>SHEET 1 OF 1</p>	<p>3</p>
<p>FOR PARTS, CALL 1.800.342.7498</p>	<p>4</p>	<p>5</p>	<p>1</p>	<p>1</p>

C300 & C400 HUB AND SPINDLE ASSEMBLY

300 AND 400 COMBO SPREADER HUB AND SPINDLE

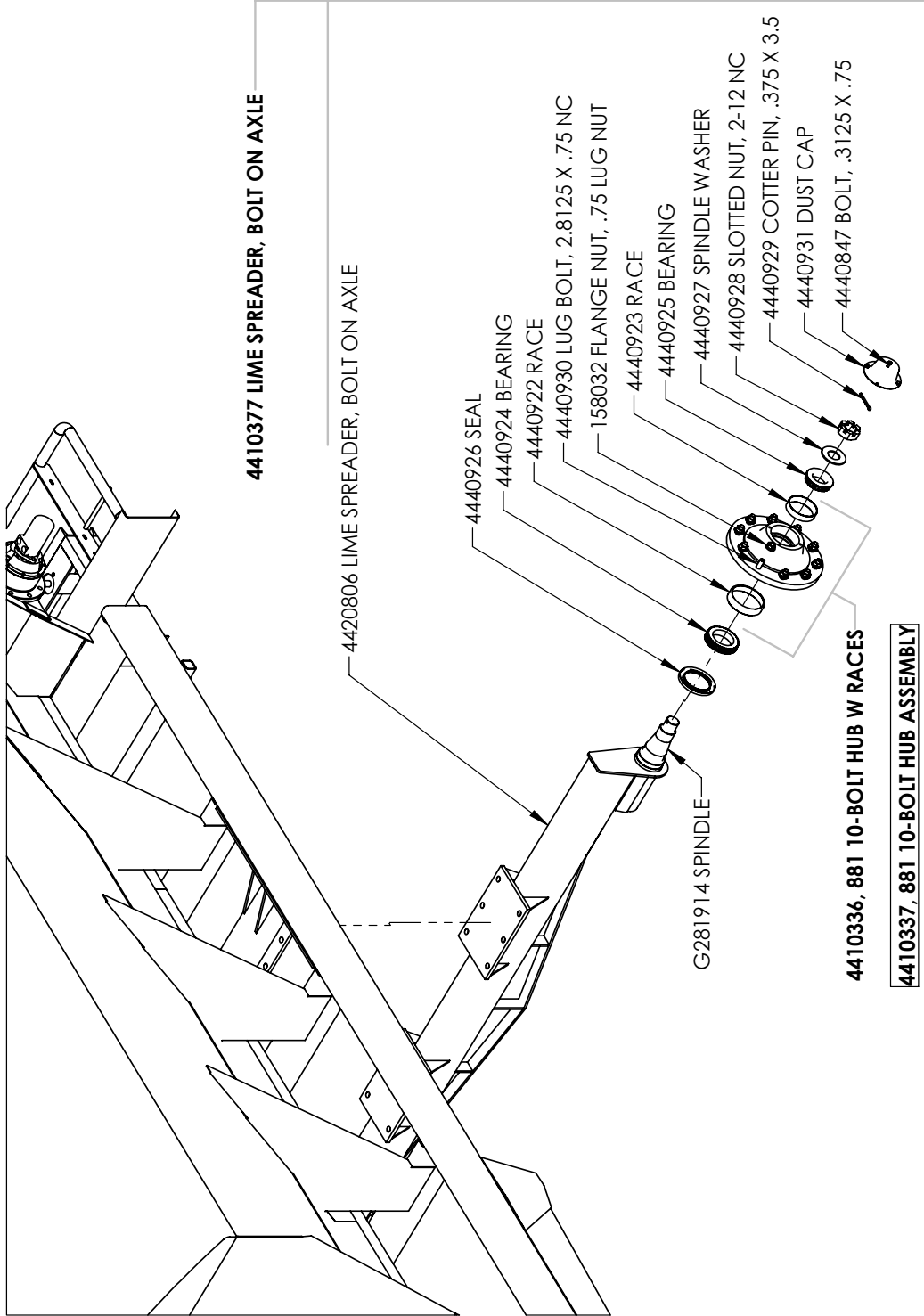

4410377 LIME SPREADER, BOLT ON AXLE

4420806 LIME SPREADER, BOLT ON AXLE

4440926 SEAL

4440924 BEARING

4440922 RACE

4440930 LUG BOLT, 2.8125 X .75 NC

158032 FLANGE NUT, .75 LUG NUT

4440923 RACE

4440925 BEARING

4440927 SPINDLE WASHER

4440928 SLOTTED NUT, 2-12 NC

4440929 COTTER PIN, .375 X 3.5

4440931 DUST CAP

4440847 BOLT, .3125 X .75

G281914 SPINDLE

4410336, 881 10-BOLT HUB W RACES

4410337, 881 10-BOLT HUB ASSEMBLY

DRAWN BY RICH SMOTHERS 4/23/2015

CHECKED BY

PRINT DATE 11/2/2015

CONFIG. 4400183 400 COMBO SPREADER

COMMENTS:

PROPRIETARY AND CONFIDENTIAL
THE INFORMATION CONTAINED IN THIS DRAWING IS THE SOLE PROPERTY OF DALTON A.G. ANY REPRODUCTION IN PART OR AS A WHOLE WITHOUT THE WRITTEN PERMISSION OF DALTON A.G. IS PROHIBITED.



DWG:

300 AND 400 COMBO SPREADER HUB AND SPINDLE

SIZE SHEET TITLE:

A Sheet1

REV

A

SCALE: 1:24 SHEET 1 OF 1

FOR PARTS, CALL 1.800.342.7498

5

4

3

2

1

REAR AREA ASSEMBLY

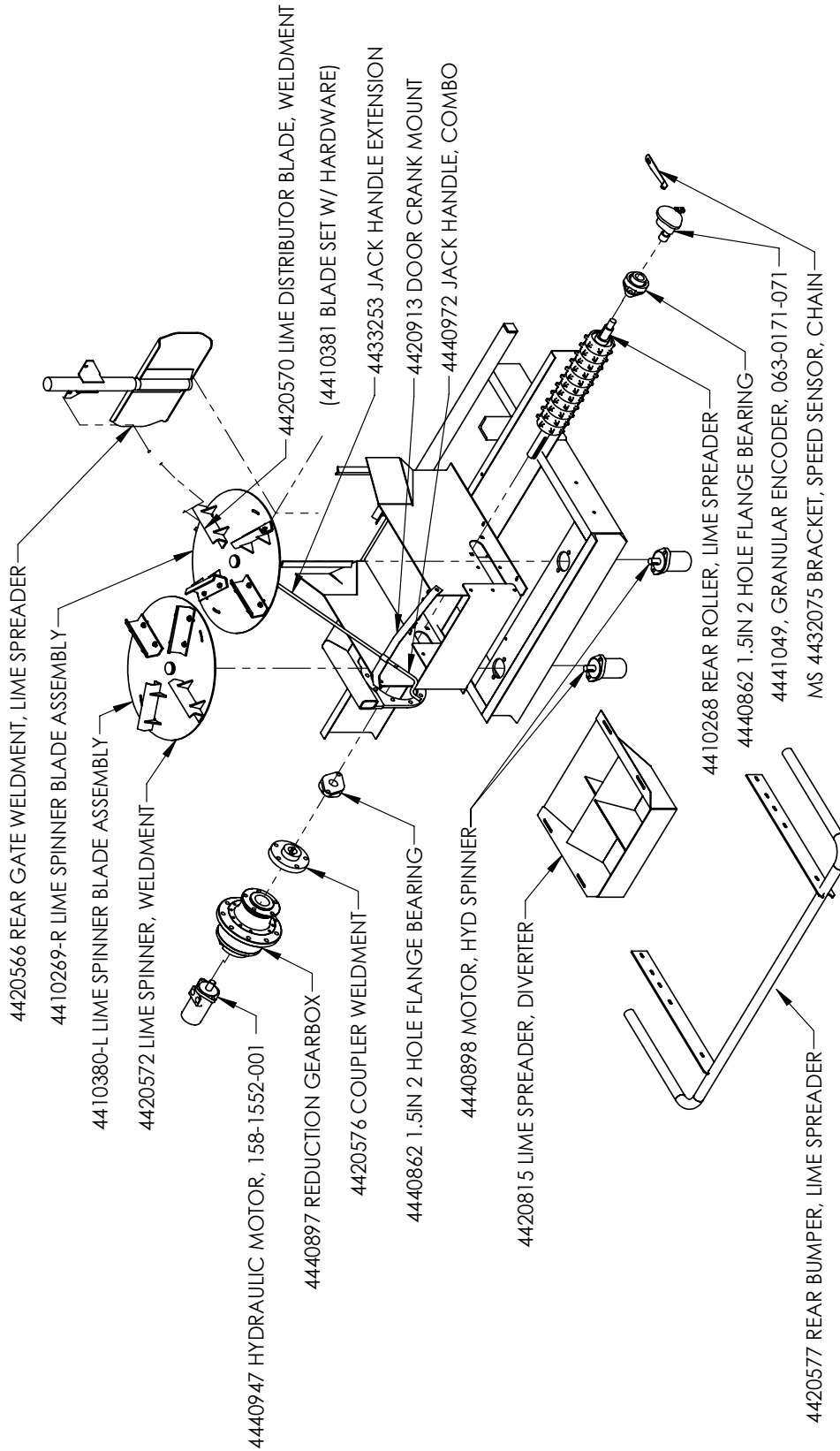

<p>PROPRIETARY AND CONFIDENTIAL THE INFORMATION CONTAINED IN THIS DRAWING IS THE SOLE PROPERTY OF DALTON AG. ANY REPRODUCTION IN PART OR AS A WHOLE WITHOUT THE WRITTEN PERMISSION OF DALTON AG IS PROHIBITED.</p>	<p>DRAWN BY: RICH SMOTHERS 4/23/2015</p> <p>CHECKED BY:</p> <p>PRINT DATE: 9/16/2016</p> <p>CONFIG: 4400183 400 COMBO SPREADER</p> <p>COMMENTS:</p>	<p>Dalton USA P R O P E R T Y S 602 E. VAN BUREN ST., LENOX, IA 50851</p> <p>DWG: REAR AREA ASSEMBLY, COMBO SPREADER</p>
<p>SIZE: SHEET TITLE: A Sheet1</p>		<p>REV: A</p>
<p>SCALE: 1:24</p>		<p>SHEET 1 OF 1</p>

5 4 3 2 1

TRACTOR HYDRAULIC DRIVEN SPINNERS

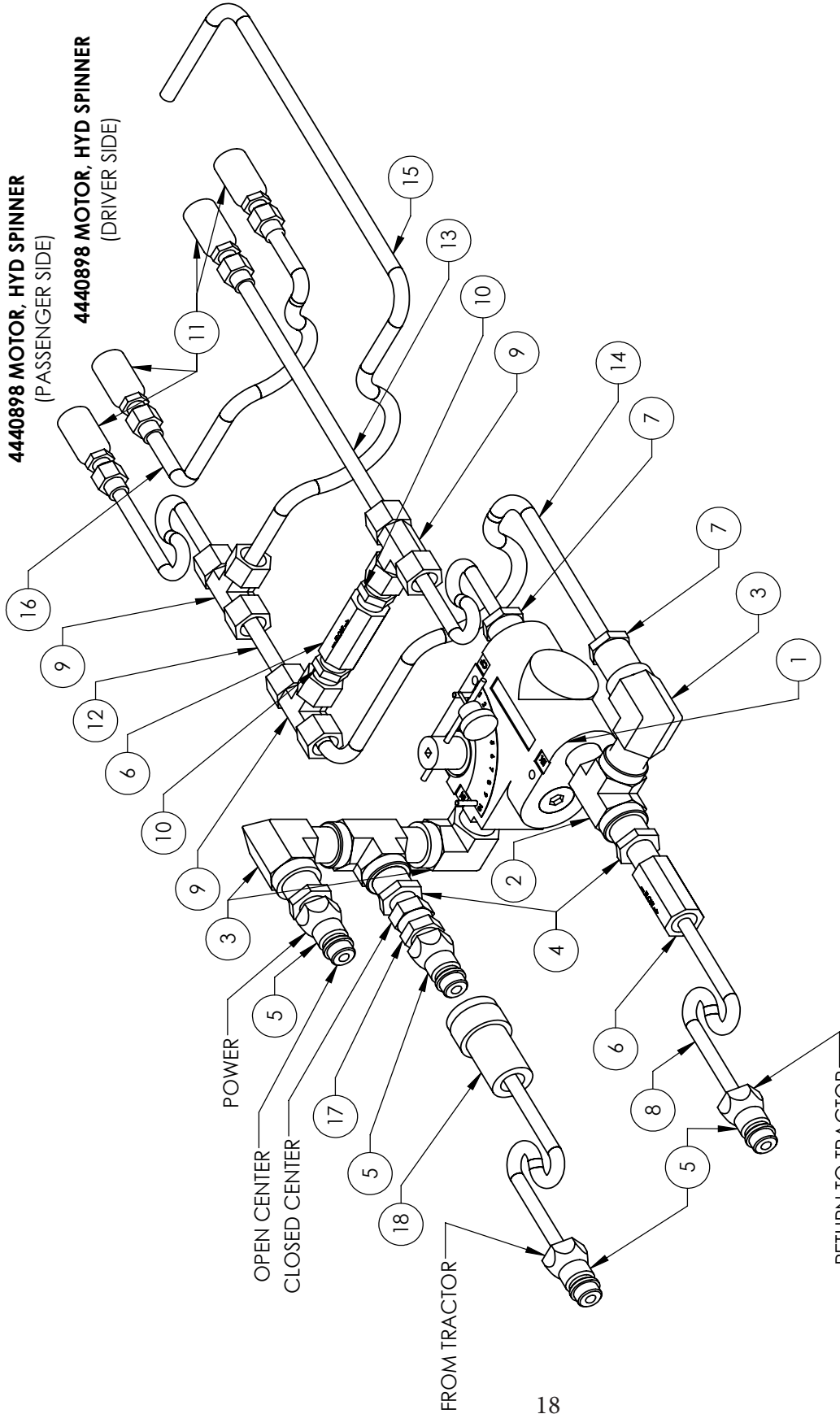

 PERFORMER 602 E. VAN BUREN ST., LENOX, IA 50851		DWG: TRACTOR HYDRAULIC DRIVEN SPINNERS, COMBO SPREADER	REV A
DRAWN BY RICH SMOTHERS	9/2/2009		
CHECKED BY	11/4/2015		
PRINT DATE	Default		
CONFIG.	Default		
COMMENTS:			
PROPRIETARY AND CONFIDENTIAL THE INFORMATION CONTAINED IN THIS DRAWING IS THE SOLE PROPERTY OF DALTON AG. ANY REPRODUCTION IN PART OR AS A WHOLE WITHOUT THE WRITTEN PERMISSION OF DALTON AG IS PROHIBITED.			
FOR PARTS, CALL 1.800.342.7498		SCALE: 1:4	SHEET 1 OF 2
5	4	3	2
			1

TRACTOR HYDRAULIC DRIVEN SPINNERS, COMBO SPREADER

#	PART NUMBER	PROCESS	Q
1	FC51-3-4, HYDRAULIC REGULATOR	PURCHASE	1
2	5602-12 T COUPLER, F-F-M, .75 INCH NPT	PURCHASE	2
3	5502-12 STELBOW, 90 DEGREE, .5 INCH	PURCHASE	3
4	540412-8, 2 INCH ADAPTER, .5INCH-.75 INCH NPT	PURCHASE	3
5	8010-4 PIONEER FITTING, .5 INCH	PURCHASE	4
6	PMR10 CHECK VALVE, .5 INCH NPT	PURCHASE	2
7	140412-8 ADAPTER, .5-.75 INCH NPT	PURCHASE	2
8	HOSE, .375 INCH	PURCHASE	4
9	1603-8-8 T COUPLER, .5 INCH NPT	PURCHASE	3
10	5404-8, 2 INCH NIPPLE, .5INCH NPT	PURCHASE	2
11	.5 O RING FITTING	PURCHASE	4
12	HOSE, .375 INCH	PURCHASE	1
13	HOSE, .375 INCH	PURCHASE	1
14	RETURN HOSE, .375 INCH NPT	PURCHASE	1
15	BACK RETURN HOSE, .375 INCH NPT	PURCHASE	1
16	JUMPER HOSE, .375 INCH NPT	PURCHASE	1
17	641679 RESTRICTOR, .06, .5 INCH NPT	PURCHASE	1
18	4050-12 PIONEER FITTING, FEMALE, .5 INCH NPT	PURCHASE	1

DRAWN BY RICH SMOTHERS
 CHECKED BY
 PRINT DATE
 CONFIG.



DWG: TRACTOR HYDRAULIC DRIVEN SPINNERS, COMBO SPREADER

SIZE SHEET TITLE: BILL OF MATERIALS
 REV A

SCALE: 1:4 SHEET 2 OF 2

PROPRIETARY AND CONFIDENTIAL
 THE INFORMATION CONTAINED IN THIS DRAWING IS THE SOLE PROPERTY OF DALTON AG. ANY REPRODUCTION IN PART OR AS A WHOLE WITHOUT THE WRITTEN PERMISSION OF DALTON AG IS PROHIBITED.

FOR PARTS, CALL 1.800.342.7498

C-SERIES HYDRAULIC SPINNERS

C-SERIES HYDRAULIC SPINNERS

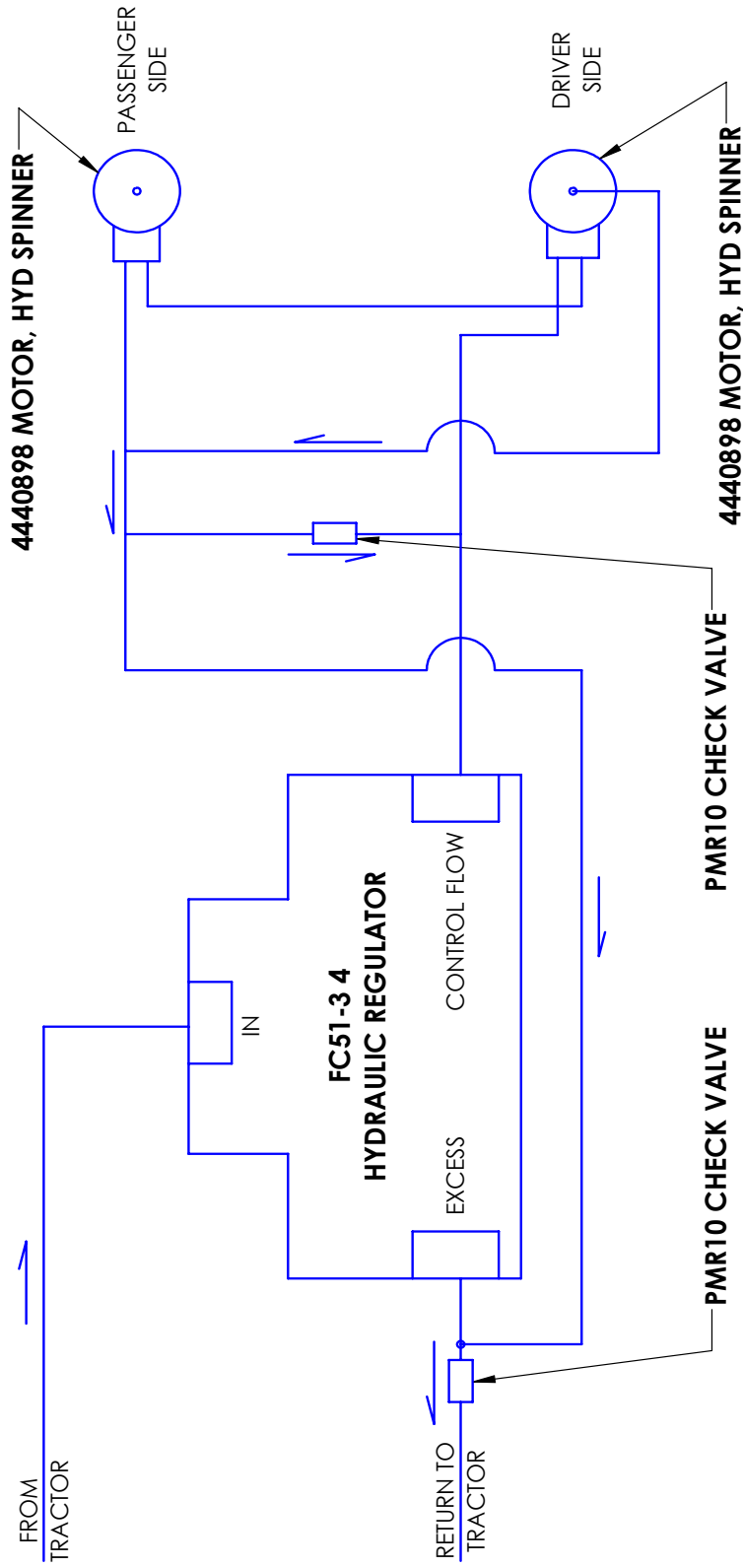

DRAWN BY RICH SMOTHERS

CHECKED BY

PRINT DATE

CONFIG.

COMMENTS:

PROPRIETARY AND CONFIDENTIAL
 THE INFORMATION CONTAINED IN THIS DRAWING IS THE SOLE PROPERTY OF DALTON A.G. ANY REPRODUCTION IN PART OR AS A WHOLE WITHOUT THE WRITTEN PERMISSION OF DALTON A.G. IS PROHIBITED.



DWG: C-SERIES HYDRAULIC SPINNERS

SIZE SHEET TITLE: Sheet1 REV A

SCALE: 1:12 SHEET 1 OF 1

FOR PARTS, CALL 1.800.342.7498

1 2 3 4 5

VARIABLE RATE CONTROL, ELECTRICAL PLAN

CONTROL CONSOLE W/MASTER SWITCH
SCS 660; 063-0172-542

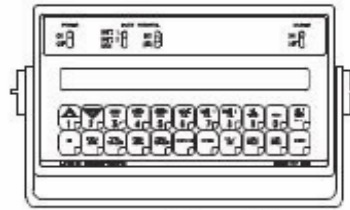

CONSOLE CABLE
3' LONG; 115-0150-707

ORANGE - +12VDC SWITCHED
WHITE - GROUND

TO SWITCHED POWER

RADAR POWER CABLE
12' 115-0159-539

SPEED EXTENSION CABLES
10': 115-0171-262
12': 115-0159-032
18': 115-0171-239
24': 115-0159-018
28': 115-0171-241
34': 115-0171-225

EXTENSION CABLE
24': 115-0159-717
12': 115-0171-501

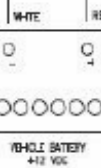

SPEED SENSORS

RADAR (RADAR ONLY): 063-0172-143
RADAR (NOT WITH POWER CABLE): 117-0159-822

** WIDE VARIETY OF WHEEL DRIVE, SPEEDOMETER AND RADAR ADAPTER CABLING. CONSULT RAVEN SALES REPRESENTATIVE FOR PART NUMBERS **

FLOW CABLE
21' 115-0159-787

ENCODER

063-0171-071
180 CPR - 30 RPM MAX
063-0171-114
36 CPR - 250 RPM MAX
063-0171-443
180 CPR

FLOW EXTENSION CABLES
6' LONG: 115-0159-016*
12' LONG: 115-0159-017*
24' LONG: 115-0159-019*
36.5' LONG: 115-0171-544*

TO CLUTCHES AND SENSORS

HYDRAULIC CONTROL VALVE

Calculate the Spreader Constant Value

The Spreader Constant value can be calculated in one of two ways: by performing a mathematical calculation, or by performing a “catch test” by applying and measuring the product used.

Note: The Spreader Constant value must be recalculated every time the gate opening dimensions are changed!

Formula Calculation:

First, use a tape measure to measure the following dimensions on the machine:

- Gate height (GH) in inches [cm]
 - Gate width (GW) in inches [cm]
 - Distance of travel (D) in inches [cm] of the belt per one revolution of the sensor
- Second, determine the number of pulses emitted by the encoder per one revolution of the sensor.

1. Enter a METER CAL value of 10.

2. Enter a TOTAL VOL value of 0.

3. Turn the sensor exactly one revolution. The value in TOTAL VOLUME is the number of encoder pulses per sensor revolution.

Third, determine the cubic feet [cm] of discharge per one revolution of the sensor by multiplying the distance of the belt travel per one sensor revolution by the gate height by the gate width, then dividing it by 1728 (not necessary for determining cubic cm).

For Example:

Distance of Belt Travel per 1 Sensor Revolution (D) = 13 inches [33 cm]

Gate Height (GH) = 3 inches [18 cm]

Gate Width (GW) = 8 inches [38 cm]

Number of Encoder Pulses per 1 Sensor Revolution (P) = 180 or 360 (Dependent on Encoder)

$$\frac{D \times GH \times GW}{1728} = \text{Cubic Feet of Discharge per 1 Sensor Revolution}$$

$$\frac{13.75 \times 8 \times 20}{1728} = 1.27 \text{ cubic feet of discharge per 1 sensor revolution}$$

Finally, calculate the Spreader Constant value using one of the following formulas, using the example of a 180 CPR granular encoder. Write down this number for future reference when programming the console.

Rate in Pounds: *180 Encoder Used As Example*

$$\frac{P}{\text{Cubic Feet of Discharge per 1 Sensor Revolution}} = \text{Spreader Constant Value}$$
$$\frac{180}{1.27} = 994 \text{ Spreader Constant}$$

Calibration Numbers for Variable Rate Ready Spreaders Lime Spreader

***For 180 Pulse Encoder* 063-0171-071**

Inches of belt travel per revolution of rear roller = 13.45"

Encoder pulses per revolution of rear roller = 180

Gate Width = 20"

Gate Height = Actual inches above the floor (chain is ½" thick)

Meter Cal = Product Density

Speed Cal w/ Sky Trak = 600

Speed Cal w/Astro II = 783

Spreader Constant #'s

2" Gate Height = 578

3" Gate Height = 385

4" Gate Height = 289

5" Gate Height = 231

6" Gate Height = 193

7" Gate Height = 165

8" Gate Height = 145

*The spreader constant is entered by holding down the meter cal. button until the spreader constant menu comes available.

*These numbers are a good starting point and may be need to be adjusted slightly if your actual rate is off.

Calibration Numbers for Variable Rate Ready Spreaders Lime Spreader

***For 360 Pulse Encoder * 063-0173-937**

Inches of belt travel per revolution of rear roller = 13.45"

Encoder pulses per revolution of rear roller = 360

Gate Width = 20"

Gate Height = Actual inches above the floor (chain is ½" thick)

Meter Cal = Product Density

Speed Cal w/ Sky Trak = 600

Speed Cal w/Astro II = 783

Spreader Constant #'s

2" Gate Height = 1156

3" Gate Height = 771

4" Gate Height = 578

5" Gate Height = 463

6" Gate Height = 385

7" Gate Height = 330

8" Gate Height = 289

*The spreader constant is entered by holding down the meter cal. button until the spreader constant menu comes available.

*These numbers are a good starting point and may be need to be adjusted slightly if your actual rate is off.

PARTS ORDERING PROCEDURE

Your Dalton Ag dealer is interested in your new fertilizer application equipment and has the desire to help you get the most value from it. Through the help of this manual, you will find you can do some of the regular maintenance yourself. For parts and service, contact the Dalton Ag Dealership from which you purchased your fertilizer application equipment or your local Dalton Ag dealer.

When replacement parts are required, consult the applicable illustration and parts list to obtain the correct part name and number. When requesting a replacement part, always include the following information:

1. Complete Part Number
2. Description
3. Quantity Required
4. Machine and Model Number
5. Machine Serial Number - located on the topside of the frame near hitch
6. Provide complete name and address for where and how parts are to be shipped.

NOTE: Right and left hand parts and sides of the units are determined by standing at the rear and facing in the direction of forward travel.

EQUIPMENT MODEL: _____

EQUIPMENT SERIAL NO.: _____

DATE OF PURCHASE: _____

NAME OF DEALER: _____

DEALER'S PHONE NUMBER: _____

Thank you for your business!

DaltonAg.com

602 E. Van Buren Lenox, Iowa 50851
100% Employee Owned

800.342.7498

NOTES



www.daltonag.com

602 E. VAN BUREN / LENOX, IOWA 50851 / 800-342-7498