



OPERATING AND PARTS MANUAL

500, 600 & 800 TANDEM SPREADERS

2018



TABLE OF CONTENTS

TO YOU THE OWNER.....	1
LIMITED WARRANTY STATEMENT.....	2
NEW MACHINE CHECKOUT.....	3
OPERATION AND SAFETY.....	4
LUBRICATION SCHEDULE.....	5
LUBRICATION DETAIL	6
BOLT TORQUE CHART.....	7
MACHINE ADJUSTMENT.....	8
SPECIFICATIONS.....	9
SPREAD ADJUSTMENT AND APPLICATION RATES.....	10
SPREAD PATTERN DETAILS.....	11
50' SPREAD SETUP.....	12
DISTRIBUTOR BLADE TUNING.....	13
40' SPREAD PATTERN DECAL.....	14
50' SPREAD PATTERN DECAL.....	15
50' SPREAD PATTERN DECAL, VARIABLE RATE.....	16
FRAME AND DRIVELINE.....	17
540 PTO.....	18
1000 PTO.....	19
5 TON WALKING BEAM, NO BRAKES.....	20
5 TON WALKING BEAM, 2 WHEEL BRAKES.....	21
5 TON WALKING BEAM, 4 WHEEL BRAKES.....	22
6 & 8 TON WALKING BEAM, NO BRAKES.....	23
6 & 8 TON WALKING BEAM, 2 WHEEL BRAKES.....	24
6 & 8 TON WALKING BEAM, 4 WHEEL BRAKES.....	25
GROUND DRIVE ASSEMBLY.....	26
FRONT TANK ASSEMBLY.....	27
REAR AREA ASSEMBLY.....	28
GATE JACK ASSEMBLY.....	30
IDLER MOUNT, CHAIN BELT.....	31
DISTRIBUTOR GEAR BOX.....	32
HYDRAULIC SPINNER GEAR BOX.....	33
TRACTOR HYDRAULIC DRIVEN SPINNERS.....	34
DIGITAL READOUT.....	35
VARIABLE RATE CONTROL, ELECTRICAL PLAN.....	36
VARIABLE RATE CONTROL, HYDRAULIC PLAN.....	37
SPREADER CONSTANT VALUE.....	38
CALIBRATION NUMBERS FOR VARIABLE RATE SPREADERS.....	39
DA12 ACTUATOR INSTRUCTIONS AND BLEEDING.....	40
DA12 ACTUATOR PARTS LIST.....	41
GATE MARKER DECAL.....	42
DECAL LAYOUT.....	43
PARTS ORDERING PROCEDURE.....	45

TO YOU, THE OWNER

Your Dalton Ag Equipment is the most modern, up-to-date, versatile, machine available for fertilizer application. The machine is the result of many years of experience, research, development and testing of equipment for fertilizer application. It is soundly engineered and carefully built to rigid specifications. It is of rugged and simple construction, with a minimum of moving parts.

However, to obtain maximum performance from your Dalton Ag Equipment, it is necessary to follow the instructions and safety suggestions in this manual. Each section has been carefully prepared for the purpose of providing needed and valuable information to the owner and operator. Each operator of this unit should be familiar with the contents of this manual. Keep it in a safe and convenient location. THERE ARE MANY SAFETY SUGGESTIONS (CAUTION AREAS) PRINTED THROUGHOUT THIS MANUAL. CAREFULLY READ THEM ALL BEFORE OPERATING THIS UNIT.

DESIGN IMPROVEMENTS

Dalton Ag Products follows a policy of continuous products improvement. We therefore reserve the right to make design improvements, and changes in specifications and prices, without incurring obligations to make revisions or additions to equipment previously sold.

**REGISTER
WARRANTY
ONE OF
FOUR WAYS**

- Register on-line at:
www.daltonag.com
- Fax your completed warranty registration form to:
641-333-4429
- Email your completed warranty registration form to:
office@daltonag.com
- Mail your completed warranty registration form to:
Dalton Ag, Inc.
P.O. Box 70
Lenox, IA 50851



LIMITED WARRANTY STATEMENT

DALTON AG, INC. warrants to the original purchaser only that all products manufactured under the Dalton Ag and Mobility Brands will be free from defects in material and workmanship under normal use and service.

DALTON AG's obligation under this warranty is limited to repairing or replacing, as it may elect, free of charge and without charge for installation, at the place of business of a dealer or distributor authorized to handle the equipment covered by this warranty or at a DALTON AG facility, any parts that prove, in DALTON AG's judgment, to be defective in material or workmanship within two (2) years after delivery to the original purchaser. DALTON AG shall not be liable for personal injuries or any special or consequential damages of any kind, either direct or indirect. This warranty is subject to acts of God, fire and existing conditions of supply and demand, production, ability or inability to deliver, or for any other valid reason beyond the reasonable control of DALTON AG. No distributor, dealer, agent or DALTON AG employee (other than DALTON's President in writing) is authorized to extend or make any other or further express or implied warranty or incur any additional obligation on DALTON AG's behalf in connection with the sale of this product.

Customer Responsibility

Product Registration - It is a condition of this warranty that the original purchaser fill out the warranty card furnished by DALTON AG and return it to DALTON AG to be recorded in DALTON AG's owner file. Registration may also be done on line at www.DaltonAg.com/warrantyregistration. If the original purchaser's card or electronic registration is not on file at DALTON AG's office, the warranty period will extend only from date equipment was picked up or shipped from the DALTON AG plant.

Maintenance - It is the customer's responsibility to maintain their equipment in accordance with the instructions provided in the Operator's Manual. DALTON AG recommends that you keep records and receipts as the customer may be required to verify the maintenance instructions have been followed.

Operation - It is the customer's responsibility to operate the equipment only for the purpose for which it was designed and in accordance with all safety and operational recommendations contained in the Operator's Manual. If a defect in materials or workmanship occurs, it is the customer's responsibility to cease operating the equipment until authorized repairs are made.

Damage incurred from continued operation after a defect is discovered may not be covered by this warranty.

What this Warranty Covers

This warranty covers failures caused by defects in materials or workmanship only.

This Warranty does not cover failures caused by:

- Improper operation
- Natural calamities
- Unauthorized modifications
- Unauthorized repairs
- Use of Non DALTON AG parts
- Neglected maintenance
- Usage contrary to the intended purpose of the product

This Warranty does not cover replacement of Wear or Maintenance Items including, but not limited to:

- Lubricants
- Filters
- Hoses
- Tires
- Disks
- Chains
- Idlers
- Blades
- Belts
- Bearings

This Warranty does not cover:

- Pickup and delivery of the equipment
- Service Calls or Travel Time to and from sites
- Rental of replacement equipment during repair period
- Products that have been declared a total loss and subsequently salvaged
- Overtime labor charges

Parts Warranty

DALTON AG warrants its replacement parts against defects in materials or workmanship for a period of 90 days or the remainder of the product warranty, whichever is longer under the terms set out above. Remedy for defective replacement parts for units that are beyond the original product warranty, will be limited to replacement of the failed part.

DaltonAg.com

602 E. Van Buren Lenox, Iowa 50851
100% Employee Owned

PHONE: 800.342.7498
FAX: 641.333.4429

NEW MACHINE CHECKOUT

Before attempting to use or operate the spreader it is important to be thoroughly familiarized with the contents of this manual. The machine should then be checked using the following check list:

1. Ground drive tire inflated to 35 PSI. Flotation tires inflated to 32 PSI for tandem axle spreaders.
2. All bearings lubricated and tightly mounted with collars securely locked.
(See lubrication schedule page 5.)
3. Conveyor chain, drive chain & ground drive chain adjusted to correct tension. Conveyor chain should clear frame members by $\frac{1}{2}$ " - $\frac{3}{4}$ ".
4. Sprockets tightened & in proper alignment.
5. Inspect entire machine for loose bolts, especially in the spinner assembly and drive line area.
6. Distributor fan blades set properly. (See spread adjustment and application rates.)
7. Setting of metering gate. With the pointer on the number 1 of the spread rate chart decal, the lower edge of the metering gate should be $1\frac{1}{4}$ " above the trough floor.
8. Make sure that the ground drive travel limit bolt is set to allow $1\frac{1}{4}$ " disengagement clearance between ground drive tire and flotation tire to allow a maximum travel of 7 turns of the crank handle after the ground drive tire makes contact with the flotation tire.
9. Tighten wheel bolts daily – 75 foot pounds for tandem axle spreaders.
10. Test operation of brakes and brake actuator. Make sure master cylinder is full of hydraulic fluid.
11. Check drive line for ease of operation by turning shaft by hand. If the foregoing inspection reveals that additional lubrication or adjustment is required, refer to the proper section of this manual for detailed instructions.
12. Ground drive wheel and universal joint shear pins in place and tight.
13. Check both spinner gear boxes for oil; fill to level of pipe plug with SAE No. 90 non-detergent oil.

OPERATION

SPREADER SAFETY

Before starting in motion please read the following words of caution.

- A. It is recommended that initial spreading be done in as low a range as possible to permit easy break-in.
- B. Always shut off or disconnect power to spreader before attempting to repair or adjust the spreader.
- C. Do not transport machine with ground drive wheel engaged.
- D. NEVER back-up spreader with ground drive wheel engaged.
- E. Make sure that the towing vehicle brakes are operating properly and are capable of stopping the towing vehicle.
- F. If a pick-up is used as the towing vehicle, it is wise to add ballast for additional safety and traction. We recommend that all towing vehicles be ballast loaded to their recommended G.V.W.
- G. Hitches should be of heavy construction and should be welded or bolted directly to the towing vehicle frame. Hitches should be checked routinely for loose bolts, cracked welds, etc.
- H. Never tow a spreader with a drawbar pin less than 1" in diameter. Pins should also have a locking device.
- I. Do not tow spreader at speeds in excess of 20 mph loaded or 40 mph empty.
- J. Remember, that the stopping and braking distances vary with load and vehicle speed. It is well to familiarize yourself with the characteristics of your machine under different load and speed conditions.
- K. Be sure to attach safety break-away chain and the safety chain to towing vehicle to assure control of spreader in the case of pin or hitch failure.
- L. The unit is designed for hitching to vehicles with drawbar heights between 12 and 18 inches above the ground level. It will operate with all standard tractor hitches and PTO's. WARNING: Hydraulically mounted drawbars must be securely and mechanically locked because a fully loaded spreader applies a load in the order of 2000 lbs. to the hitch.
- M. WARNING: Remember this unit is designed for agricultural use only and is primarily an off-the-road vehicle and should be towed at tractor speeds ONLY, not to exceed 20 mph loaded or 40 mph empty. Inspect hubs routinely to see if they are heating, which indicates either a need for lubrication or improper adjustment of brakes or bearings, also check stud nuts for tightness.
- N. WARNING: The maximum capacity of this unit is 6 tons (600) or 200 cubic feet, based on a material density of 60 pounds per cubic foot. DO NOT EXCEED THIS LIMIT!

OPERATING INSTRUCTIONS

Please read the following completely before spreading.

- 1) Attach spreader to towing vehicle, make sure hitch and hitch pin are sound.
- 2) Attach PTO shaft to proper rpm PTO.
- 3) Spinner discs, adjustable chute and conveyor floor should be clean for accurate metering.
- 4) Set metering gate to desired spread rate according to decal on the back end sheet of tank. Always keep the machine in the lowest possible range.
- 5) Before starting to spread, rotate the ground drive wheel several revolutions by hand to make sure the conveyor chain is operating freely. If chain is frozen or moves with too much resistance, correct problem before using spreader.
- 6) If the ground drive wheel operates properly, check with chain and sprocket arrangement for desired range setting and chain tension.
- 7) When spreading is complete, disengage ground drive assembly from the tire and install transport lockup.

LUBRICATION SCHEDULE

DAILY LUBRICATION SCHEDULE	DRIVELINE	ALL MODELS	(4) BEARINGS	
			(2) U-JOINTS	
	GROUND DRIVE	GROUND DRIVE		(1) BEARING
				(4) U-JOINTS
				(2) TELESCOPING TUBES
	CONVEYOR DRIVE	ALL MODELS		(6) BEARINGS
	GROUND DRIVE	ALL MODELS		(2) SHAFT HOUSINGS
				(2) U-JOINTS
			TELESCOPING TUBE	
			(2) SQUIRTS OF SAE 90 OIL INTO JACK CRANK	
			OIL CAP	

Pay particular attention to the daily cleaning and greasing of the telescoping tube assembly.

WEEKLY LUBRICATION SCHEDULE	CHAINS	OIL	LUBRICATE PIN JOINTS WITH SAE 80-90
	PTO SHAFT	GREASE	(2) U-JOINTS AND SLIP TUBE
	SPINNER GEARBOX	GREASE	UNIVERSAL GREASE ON EACH FITTING UNDER SPINNER HUB

MONTHLY LUBRICATION SCHEDULE	DRIVE SHAFT SPLINES	COAT WITH GREASE OR ANTI-SEIZE COMPOUND
	SPINNER GEAR BOX	CHECK TO SEE THAT OIL LEVEL IS UP TO OIL LEVEL PLUG. USE SAE 90 OIL

ANNUAL LUBRICATION SCHEDULE	WHEEL BEARINGS	REPACK
	GEAR BOXES	DRAIN, FLUSH, AND REFILL WITH SAE 90 OIL

MAINTENANCE SCHEDULE

WEEKLY	WASH SPREADER
	CHECK GROUND DRIVE TIRE INFLATION (22 PSI)
	CORRECT BELT TENSION
	ADJUST TENSION OF CONVEYOUR AND DRIVE CHAINS (SEE MACHINE CHECKOUT)

SEMI-ANNUALLY	TIGHTEN LOOSE BOLTS
	REPLACE WORN OR FAILED PARTS
	TOUCH-UP PAINT

LUBRICATION DETAIL

LUBRICATION
DETAIL

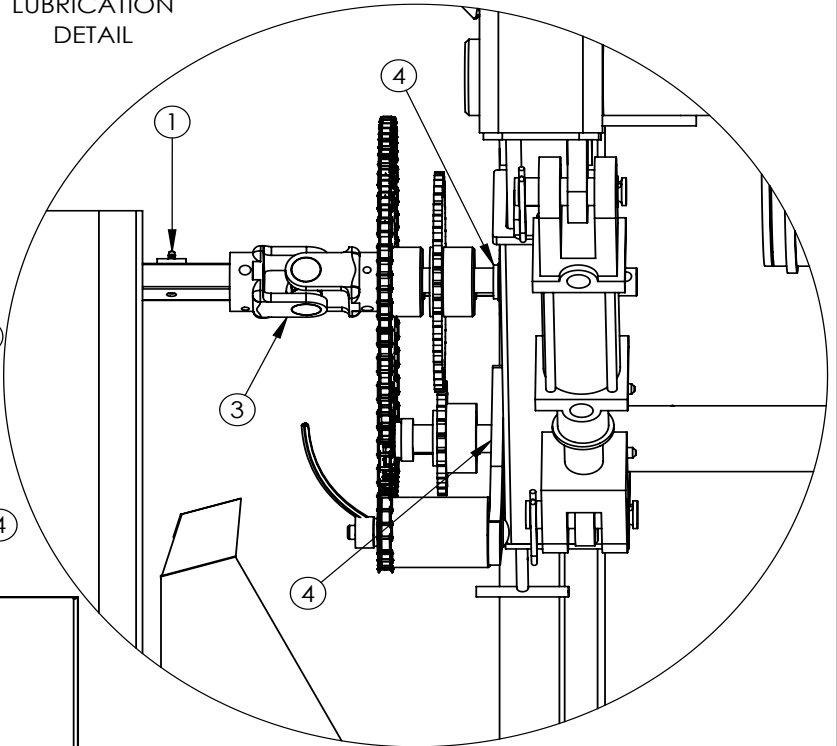
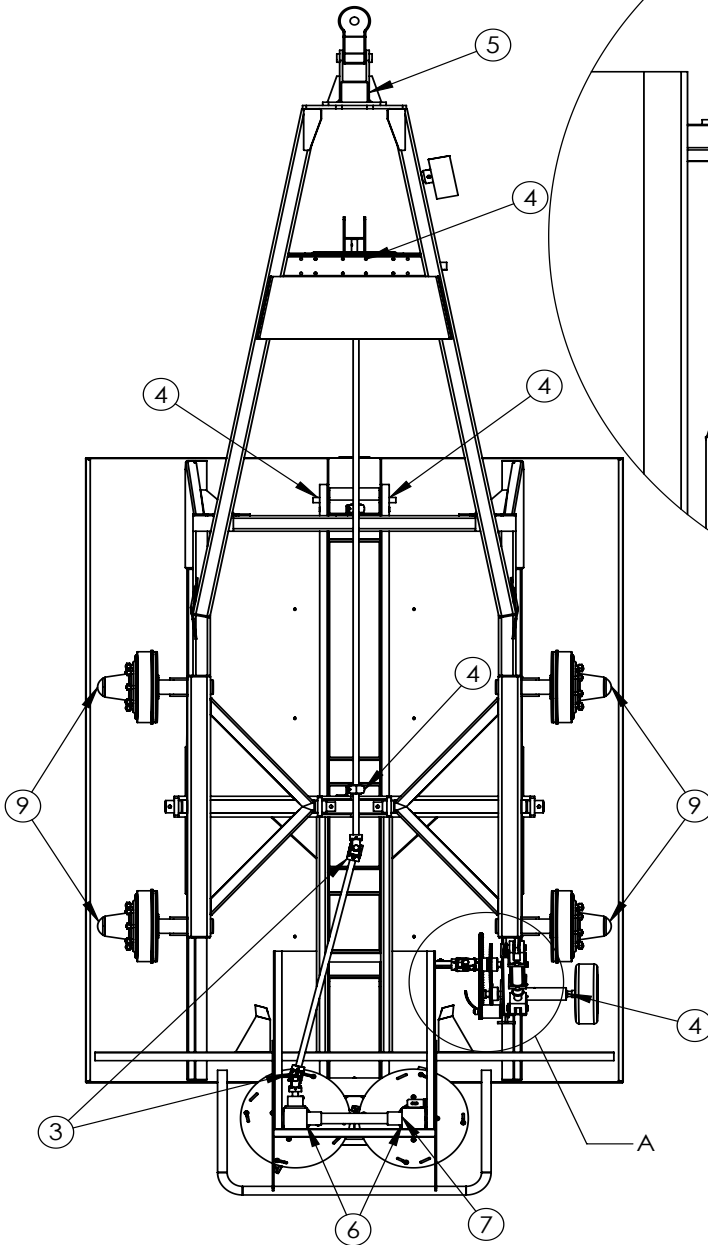

DETAIL A
SCALE 1 : 6

LUBRICATION SCHEDULE		
1	SLIP JOINT	DAILY
2	PIVOT BUSHING	EVERY 10 HRS
3	UNIVERSAL JOINT	EVERY 15 HRS
4	BALL BEARING	EVERY 15 HRS
5	ACTUATOR	EVERY 15 HRS
6	TOP GEAR BOX BEARING	EVERY 15 HRS
7	GEAR BOX	EVERY 75 HRS
8	GATE JACK (OIL)	WEEKLY
9	WHEEL BEARING	TWICE A YEAR

DRAWN BY	RICH SMOTHERS	8/7/2017
CHECKED BY		
PRINT DATE	8/16/2017	
CONFIG.	Default	
COMMENTS:		



DWG: TANDEM SPREADER LUBRICATION SCHEDULE





SIZE	SHEET TITLE:	Sheet1	REV
A			A
SCALE: 1:32	SHEET 1 OF 1		

PROPRIETARY AND CONFIDENTIAL
THE INFORMATION CONTAINED IN THIS DRAWING IS THE SOLE PROPERTY OF DALTON AG. ANY REPRODUCTION IN PART OR AS A WHOLE WITHOUT THE WRITTEN PERMISSION OF DALTON AG IS PROHIBITED.

FOR PARTS, CALL 1.800.342.7498

IMPORTANT : Over tightening hardware can be as damaging as under tightening. Tightening beyond recommended torque will reduce the fastener's shock load capacity.

BOLT TORQUE CHART

SIZE	 SAE GRADE 2		 SAE GRADE 5		 SAE GRADE 8		 L9	
	ASSEMBLY TORQUE		ASSEMBLY TORQUE		ASSEMBLY TORQUE		ASSEMBLY TORQUE	
	DRY	LUBRICATED	DRY	LUBRICATED	DRY	LUBRICATED	LUBRICATED	
1/4-20	66*	49*	8	75*	12	9	11	
1/4-28	76*	56*	10	86*	14	10	13	
5/16-18	11	8	17	13	20	18	21	
5/16-24	12	9	19	14	25	20	23	
3/8-16	20	15	30	23	45	30	33	
3/8-24	23	17	35	25	50	35	38	
7/16-14	30	24	50	35	70	55	60	
7/16-20	35	25	55	40	80	60	65	
1/2-13	50	35	75	55	110	80	95	
1/2-20	55	40	90	65	120	90	105	
9/16-12	65	50	110	80	150	110	140	
9/16-18	75	55	120	90	170	130	150	
5/8-11	90	70	150	110	220	170	185	
5/8-18	100	80	180	130	240	180	205	
3/4-10	160	120	260	200	380	280	290	
3/4-16	180	140	300	220	420	320	355	
7/8-9	190	140	400	300	600	460	505	
7/8-14	210	155	440	320	660	500	585	
1-8	220	160	580	440	900	680	775	
1-14	240	170	640	480	1000	740	900	
1 1/8-7	300	220	800	600	1280	960	1150	
1 1/8-12	340	260	880	660	1440	1080	1325	
1 1/4-7	420	320	1120	840	1820	1360	1600	
1 1/4-12	460	360	1240	920	2000	1500	1750	
1 3/8-6	560	420	1460	1100	2380	1780	---	
1 3/8-12	640	460	1680	1260	2720	2040	---	
1 1/2-6	740	560	1940	1460	3160	2360	3250	
1 1/2-12	840	620	2200	1640	3560	2660	3650	

**ITEMS WITH * = INCH POUNDS
ALL OTHERS = FOOT POUNDS**

WARNING: Never work around any raised implement while in the raised position without using safety lockups.

MACHINE ADJUSTMENT

WHEEL BEARING ADJUSTMENT

After repacking or when inspecting wheel bearings, the following adjustment procedure should be followed. Place flat washer and spindle nut on spindle. Turn hub as you tighten nut. When a pronounced drag is felt in the bearings, back off nut one complete slot. If necessary continue to back off the nut until the next slot aligns with the cotter pin hole and install cotter pin and dust cap.

CONVEYOR CHAIN ADJUSTMENT

Loosen chain take-up locking nuts on outside of front end of trough. Adjust take-up bolts evenly until chain clears main frame members and axle tube by $\frac{3}{4}$ " $\frac{1}{2}$ ". Inspect shaft bearing mounting bolts and shaft locking collars for tightness of set screws (6 places). Reset take-up locking nuts.

STORAGE

Before storing the spreader for more than a few days, the machine should be emptied completely and thoroughly washed both inside and out. This precaution will minimize the severity of fertilizer acid corrosion, extend the useful life of the machine, and prevent damage to drive line and conveyor chain from fertilizer compaction and caking. We further recommend that the machine be thoroughly greased after washing.

Before operating the machine after extended periods of storage, re-lubricate the entire spreader in accordance with the lubrication section of this manual. Also check the entire spreader, following the New Machine Checkout Procedure to be found in a foregoing section of the manual.

Remember that oil and grease are your least expensive corrosion inhibitors.

ADDITIONAL INSTRUCTIONS:

CAUTION

Do not operate your spreader with less than one and a half (1 1/2) inch of metering gate opening as material will compact against metering gate and cause failure of the conveyor chain.

CAUTION

Do not disconnect implement from tractor with material remaining in box.

SPECIFICATIONS	5 TON SPREADER	6 TON SPREADER	8 TON SPREADER
CAPACITY (weight)	5 TONS	6 TONS	8 TONS
HOPPER LENGTH	120"	120"	120"
HOPPER WIDTH	93"	93"	93"
HOPPER CAPACITY (volume)	173 cu. Ft.	205 cu. Ft.	270 cu. Ft.
OVERALL LENGTH	220"	220"	220"
OVERALL HEIGHT	76"	83"	93"
OVERALL WIDTH	99"	99"	99"
EMPTY WEIGHT	3060 lbs.	3142 lbs.	3397 lbs.
SPREAD PATTERN	40', 50'	40', 50'	40', 50'
HOPPER CONSTRUCTION	409 stainless	409 stainless	409 stainless
SPINNER DRIVE SYSTEM	540 PTO Standard 540/1000 Optional Tractor Hydraulic Optional	540 PTO Standard 540/1000 Optional Tractor Hydraulic Optional	540 PTO Standard 540/1000 Optional Tractor Hydraulic Optional
HYDRAULIC ON/OFF FOR GROUND DRIVE	Optional	Optional	Optional
SPINNERS	Dual Gearbox Driven	Dual Gearbox Driven	Dual Gearbox Driven
JACK	5,000 lbs.	5,000 lbs.	5,000 lbs.
HITCH	HD Clevis Standard CAT4 Bull Pull Optional	HD Clevis Standard CAT4 Bull Pull Optional	HD Clevis Standard CAT4 Bull Pull Optional
AXLE	Walking Beam	Walking Beam	Walking Beam
BRAKES	2 or 4 Wheel Optional	2 or 4 Wheel Optional	2 or 4 Wheel Optional
TIRES	12.5L x 15	16.5L x 16.1	19L x 16.1
SRT ROLL TARP	Optional	Optional	Optional
LIGHT KIT	Optional	Optional	Optional
VARIABLE RATE READY	Optional	Optional	Optional
PAINT (white)	Powder Coat	Powder Coat	Powder Coat
WARRANTY	24 months	24 months	24 months

CAUTION

1. Keep all shields in place.
2. Stop engine before leaving operator's position to adjust, lubricate, clean, or unclog machines.
3. Wait for all movement to stop before servicing the machine.
4. Keep hands, feet and clothing away from power driven parts.
5. Keep off equipment unless seat or platform for operation or observation is provided.
6. Make certain everyone is clear of machine before starting.

PART No. 140959

SPREAD ADJUSTMENT AND APPLICATION RATES

For accurate and precise spreading rates, it is necessary that you know the weight in pounds per cubic foot of the material to be spread. If this is not known, the weight can be quickly and accurately determined by the following method:

1. Weigh an empty one gallon container.
2. Fill level full with the material to be used.
3. Weigh container and material, and then subtract the weight of the container to obtain the weight of the material.
4. Multiply the weight of the material by 7.5 to obtain the weight of the material in pounds per cubic foot.

Example: Typical Material-Potash

1) Weight of empty one gallon container	1.00 lbs.
2) Weight of filled container	10.35 lbs.
3) Weight of container (net)	9.35 lbs.
4) 9.35×7.5	70.125 lbs. /cu ft.

You would therefore use the column on the Spread Chart headed 70 to determine the proper gate opening for the desired application rate.

Your Mobility Spreader with its heavy-duty distributor discs and blades will apply most materials in a 50 foot wide swath.

SPREAD PATTERN DETAILS

An operational characteristic of this type of machine is the possibility of overloading the distributors at high rates of application. Such an overload results in an alteration of the spread pattern to a narrower swath with heavier application at the center. This can be avoided by reducing speed when using high application rates. MOBILITY DISTRIBUTORS ARE DESIGNED FOR A MAXIMUM APPLICATION RATE OF 1500 POUNDS PER MINUTE OF AVERAGE 60 POUND PER CUBIC FOOT MATERIAL. Caution: Be extra careful to check your spread pattern when using high application rates. Adjust your driving pattern to the actual delivered spread swath, the adjustment of the machine, and the material being used. Recommended ground or travel speed for most application rates (up to 700 pounds per acre) is 8 mph. When application rates are in excess of 700 pounds per acre, the ground speed should be proportionately reduced, (for example, at 1400 pounds per acre, maximum ground speed should be 4 mph.) We recommend that for very high application rates, to insure uniformity of application, that two lighter application passes be made preferably placing your second pass over the lap lines of the first pass. This also is recommended practice when spreading under very windy conditions or with a material that segregates easily. If your effective spread pattern is more than 50 feet wide the Metering Gate setting should be increased proportionately, according to the percentage of your spread width in excess of 50 feet. The gate setting should likewise be decreased if your effective spread pattern is less than 50 feet. EXAMPLE: 60 foot effective spread width—increase gate setting from Spread Chart by 20%; 40 foot effective spread pattern width—decrease your gate setting from Spread Chart setting by 20%. Your spread pattern can be checked accurately and visually on a freshly worked, level area of ground. Such an area is also ideally suited to adjusting and fine tuning your machine. The following diagram graphically illustrates a typical spread pattern.

Note on the illustration below that the lap point occurs at the point where the application rate is one-half of the spread chart rate. The profile of the spread pattern tapers at both edges and has a wide uniform area in the center. By careful attention to the lap point during application, a very uniform and even spread rate can be attained. The Mobility Spreaders have been designed to provide this good and uniform tapered profile to make spread width less critical. However, excessive or insufficient overlap of passes will result in a poor application pattern in the lap area of the total spread pattern. If you can attain this spread pattern and pay careful attention to the lap points, the dotted line on the illustration will represent your actual overall spread pattern.

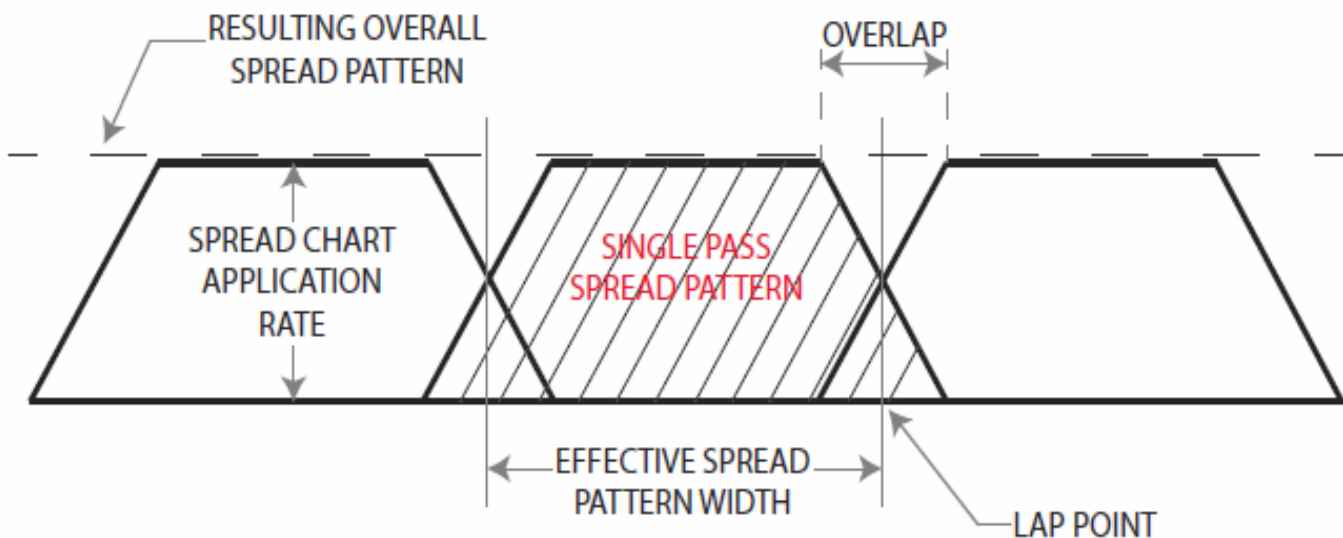

50' SPREAD SETUP

50 FT SPREAD SET UP

#	PART NUMBER	QTY.
1	1003727 DISTRIBUTOR DISC	2
2	MS 1001662 EXTRA LONG DISTRIBUTOR BLADE, 8, RIGHT	1
3	MS 1001705 EXTRA LONG DISTRIBUTOR BLADE, 8, LEFT	1
4	MS 1001718 7 INCH DISTRIBUTOR BLADE, RIGHT	1
5	MS 1001719 7 INCH DISTRIBUTOR BLADE, LEFT	1
6	MS 1001924 4.375 DISTRIBUTOR BLADE, RIGHT	1
7	MS 1001925 4.375 DISTRIBUTOR BLADE, LEFT	1
8	MS 1001926 DISTRIBUTOR BLADE, 5.5, RIGHT	1
9	MS 1001927 DISTRIBUTOR BLADE, 5.5, LEFT	1

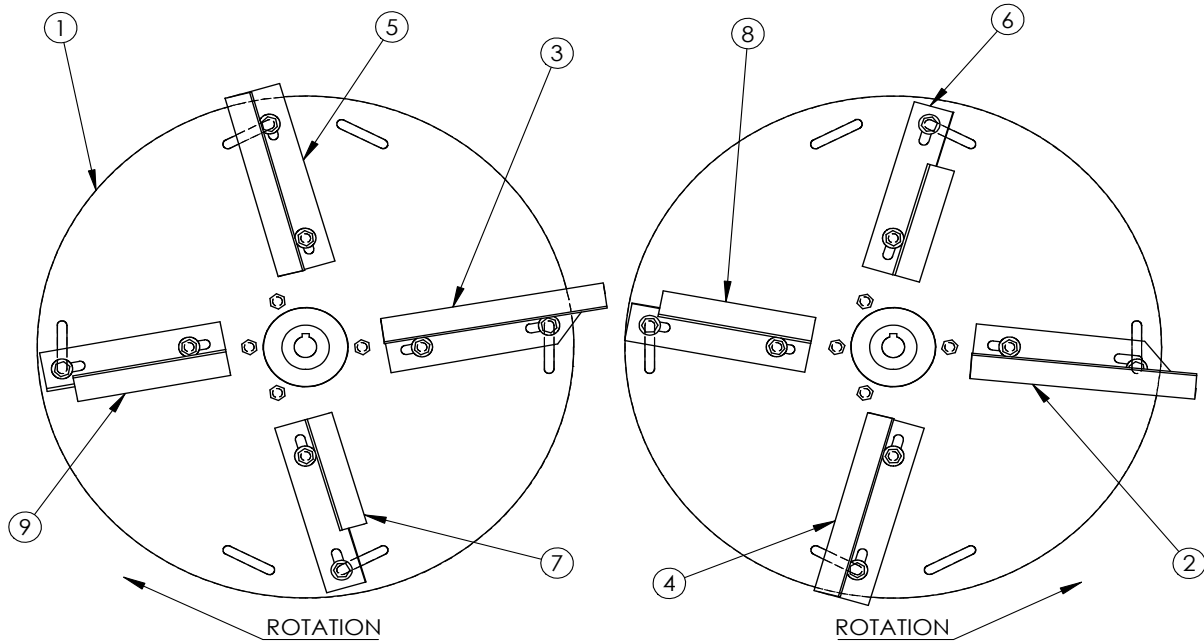

VIEWED FROM BACK OF SPREADER

DRAWN BY	RICH SMOTHERS	9/16/2013
CHECKED BY		
PRINT DATE	4/17/2017	
CONFIG.	STANDARD SPREAD PATERN, BLADE SETUP	



PROPRIETARY AND CONFIDENTIAL
 THE INFORMATION CONTAINED IN THIS DRAWING IS THE SOLE PROPERTY OF DALTON AG. ANY REPRODUCTION IN PART OR AS A WHOLE WITHOUT THE WRITTEN PERMISSION OF DALTON AG IS PROHIBITED.

COMMENTS:

DWG: 50 FT SPREAD SET UP

SIZE A	SHEET TITLE: Sheet1	REV A
------------------	------------------------	-----------------

FOR PARTS, CALL 1.800.342.7498

SCALE: 1:6 SHEET 1 OF 1

DISTRIBUTOR BLADE TUNING

FINE TUNING OF DISTRIBUTOR AND BLADE SETTINGS

All Mobility Spreaders are given an average standard factory setting of distributor blades. Such a setting, of course, cannot be perfect for all field conditions and materials. The following information will be helpful in adjusting the distributor blades on your machine to give optimum performance for your specific conditions.

Your spread pattern will be affected by 1) the material used, 2) the distributor blade setting, and 3) the rotation speed of the distributors. The distributors are designed to be operated at 750 RPM (540 tractor P.T.O. RPM). A plus or minus 10% change in distributor RPM will increase or decrease spread pattern width accordingly. An increase in PTO RPM will tend to deposit less material at the center of the spread pattern, while a decrease will deposit more material at the center. The physical characteristics of the materials being spread, which are important to the spread pattern, include bulk density, particle size, particle shape, physical strength and rugosity or surface roughness. For best performance it is recommended that you fine tune your machine to the material being used. The spreading profile and spread swath width can be changed drastically by alteration of the setting of the distributor blades. The drawing on the next page shows how blades may be extended from or retracted toward the center of the disc. Also, the angle of blade intersection with a radius of the disc may be altered. They may be advanced toward coincidence with the disc radius or retarded away from it. Further, blade lengths are not all equal. These adjustments affect the spread pattern in the following ways:

1. Advance long blades--more material to the outside of spread pattern; also will increase spread pattern width.
2. Retard long blades--opposite effect of above.
3. Advance short blades—helps eliminate problem of streaking in the middle of spread pattern.
4. Retard short blades—puts more material in the center of spread pattern.
5. Extend blades away from center of spinner—increases spread width somewhat.
6. Retract blades (more towards center of spinner)—opposite effect of above.
7. Moving flow divider (or chute) toward the front of spreader will tend to put more material in center of spread pattern. This is because material is deposited on outer edge of spinner causing it to leave earlier.
8. Moving divider toward the rear of the spreader has the opposite effect.

DISTRIBUTOR BLADE TUNING, MOBILITY

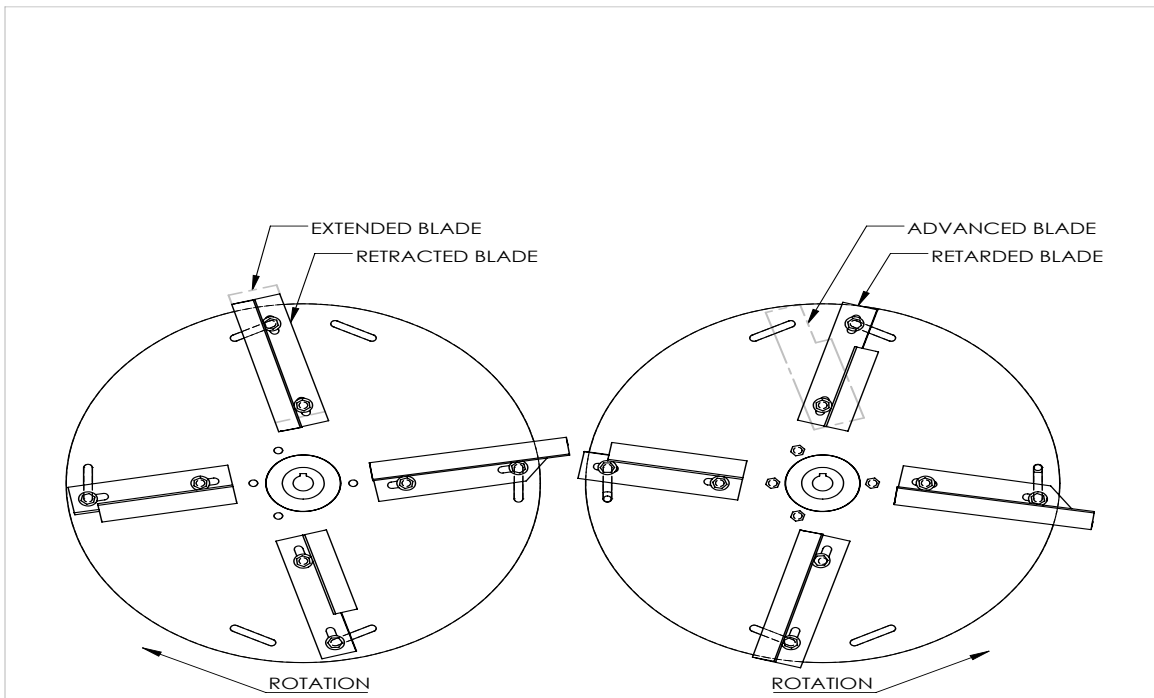

40' SPREAD

NOTICE

APPROXIMATELY 40 FT. SPREAD

800.342.7498

LOW RANGE

12 TO 72 T.

GATE OPENING	MATERIAL WEIGHT IN POUNDS PER CUBIC FOOT							
	40	45	50	55	60	65	70	75
1	55	63	69	76	83	90	96	104
1.5	83	93	103	114	124	135	145	155
2	110	124	138	151	165	179	193	206
2.5	138	155	171	189	206	224	240	258
3	165	186	206	228	248	269	289	310
3.5	193	216	241	265	289	314	338	359
4	220	248	275	303	330	358	385	413
4.5	248	279	310	341	371	403	434	464
5	275	310	344	379	413	448	481	516

HIGH RANGE

24 TO 48 T.

GATE OPENING	MATERIAL WEIGHT IN POUNDS PER CUBIC FOOT							
	40	45	50	55	60	65	70	75
1	165	186	206	228	248	269	290	310
1.5	248	279	310	341	371	404	435	465
2	330	371	413	454	495	538	580	620
2.5	413	464	515	568	619	673	725	775
3	495	558	619	681	743	806	869	930
3.5	578	650	721	794	866	941	1014	1085
4	660	743	825	908	990	1075	1158	1240
4.5	743	836	929	1021	1114	1210	1303	1394
5	825	929	1031	1135	1238	1344	1448	1550

APPLICATION RATE EXPRESSED IN POUNDS PER ACRE



PART NO. 1001118-40

50' SPREAD

NOTICE

APPROXIMATELY 50 FT. SPREAD

800.342.7498

LOW RANGE

12 TO 72 T.

GATE OPENING	MATERIAL WEIGHT IN POUNDS PER CUBIC FOOT							
	40	45	50	55	60	65	70	75
1	44	50	55	61	66	72	77	83
1.5	66	74	82	91	99	108	116	124
2	88	99	110	121	132	143	154	165
2.5	110	124	137	151	165	179	192	206
3	132	149	165	182	198	215	231	248
3.5	154	173	193	212	231	251	270	287
4	176	198	220	242	264	286	308	330
4.5	198	223	248	273	297	322	347	371
5	220	248	275	303	330	358	385	413

HIGH RANGE

24 TO 48 T.

GATE OPENING	MATERIAL WEIGHT IN POUNDS PER CUBIC FOOT							
	40	45	50	55	60	65	70	75
1	132	149	165	182	198	215	232	248
1.5	198	223	248	273	297	323	348	372
2	264	297	330	363	396	430	464	496
2.5	330	371	412	454	495	538	580	620
3	396	446	495	545	594	645	695	744
3.5	462	520	577	635	693	753	811	868
4	528	594	660	726	792	860	926	992
4.5	594	669	743	817	891	968	1042	1115
5	660	743	825	908	990	1075	1158	1240

APPLICATION RATE EXPRESSED IN POUNDS PER ACRE



PART NO. 1001118

50' SPREAD, VARIABLE RATE

50' SPREAD

HYDRAULIC SPINNERS SET AT 750 RPM

GATE OPENING	APPROXIMATE RATE
2	50 - 200
3	100 - 300
4	200 - 400
5	300 - UP

APPLICATION RATE EXPRESSED IN POUNDS PER ACRE



DALTONAG.COM
1-800-342-7498

PART NO.1001118-VR50

FRAME AND DRIVELINE

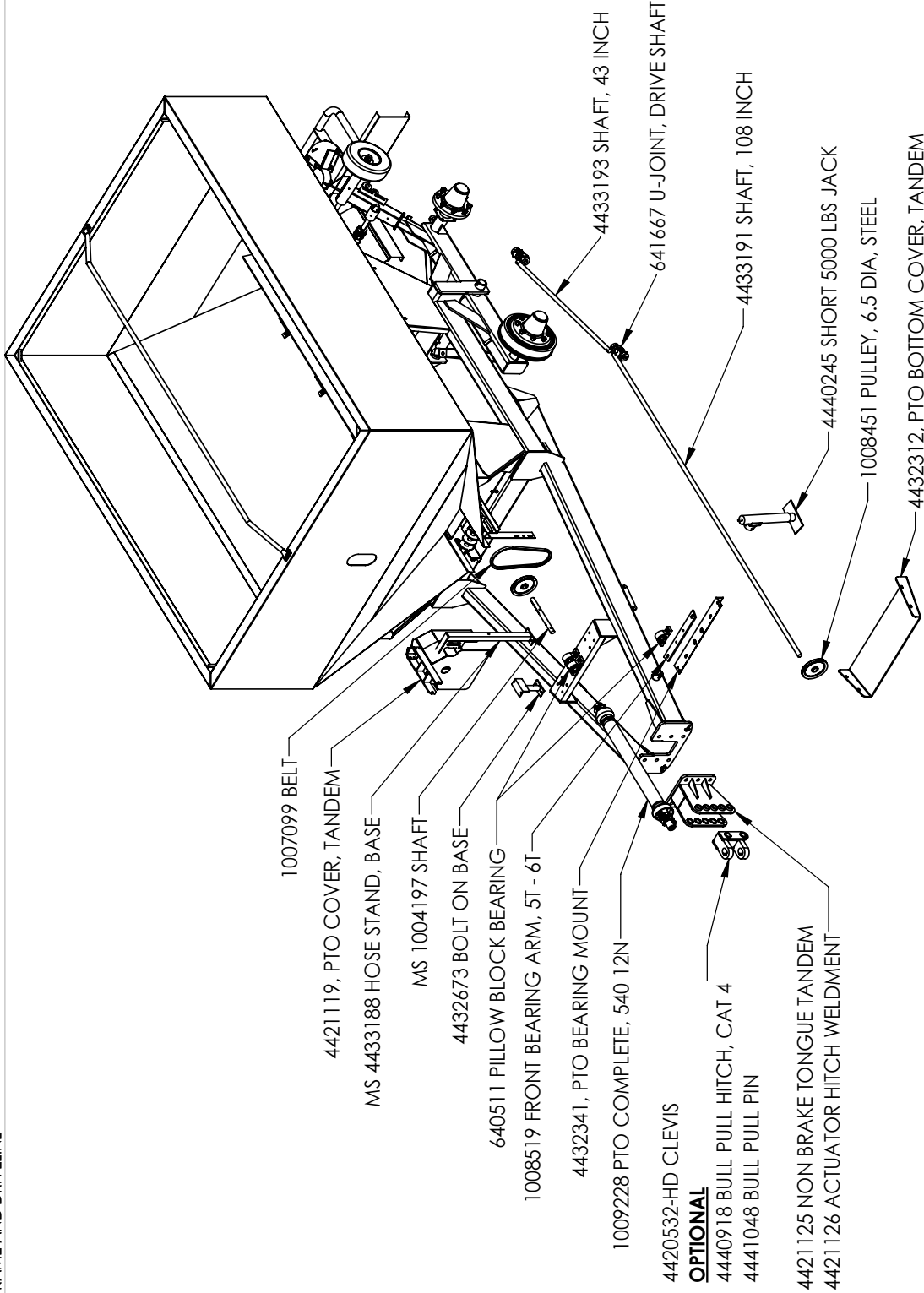

DRAWN BY	L Long	4/25/2017	 <p>Dalton USA A G P R O D U C T S 602 E. VAN BUREN ST., LENOX, IA 50051</p>	REV
CHECKED BY				FRAME AND DRIVELINE
PRINT DATE	10/25/2017		DWG:	FRAME AND DRIVELINE
CONFIG.	FRAME AND DRIVELINE		SIZE	FRAME AND DRIVELINE
COMMENTS:			SCALE:	1:36
<p>PROPRIETARY AND CONFIDENTIAL THE INFORMATION CONTAINED IN THIS DRAWING IS THE SOLE PROPERTY OF DALTON AG. ANY REPRODUCTION IN PART OR AS A WHOLE WITHOUT THE WRITTEN PERMISSION OF DALTON AG IS PROHIBITED.</p>				SHEET 1 OF 1
<p>C:_EPDM_Vault\Spreader\MOBILITY\MS Assemblies\</p>				

540 PTO

1009228 PTO COMPLETE, 540 12N

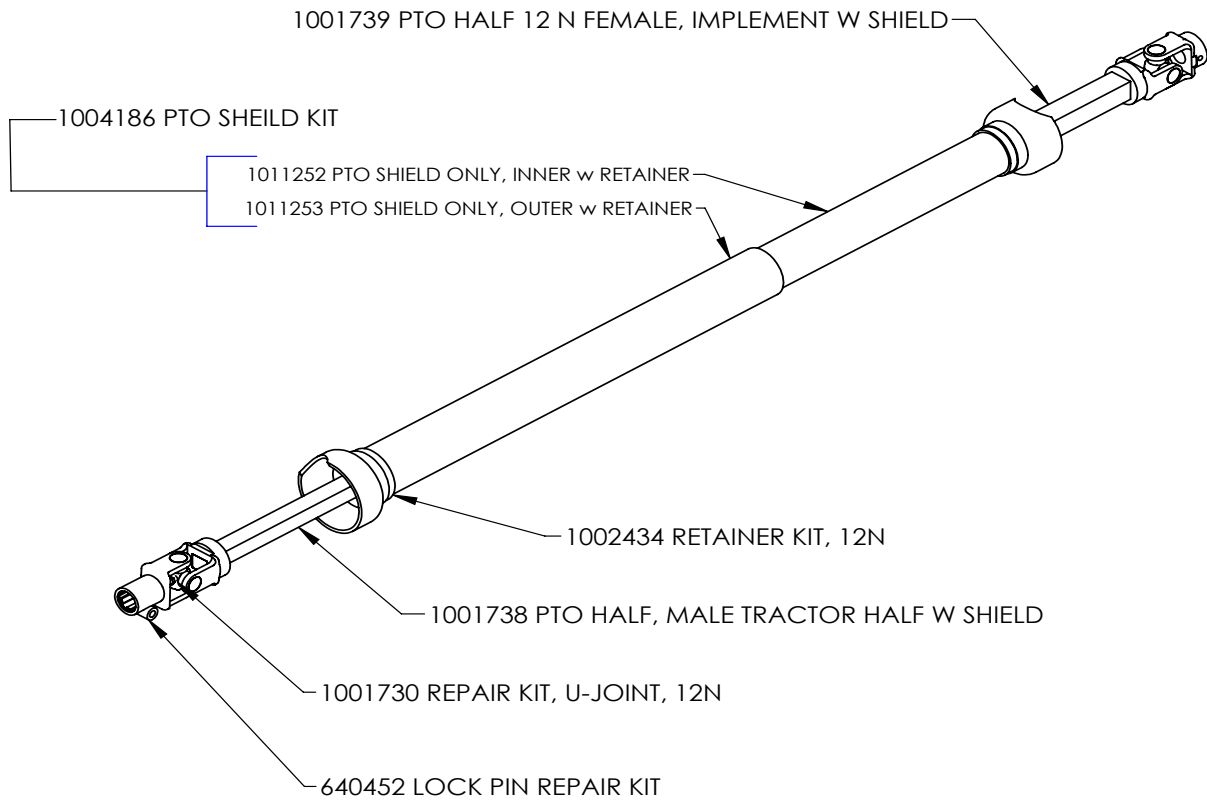

DRAWN BY	RICH SMOTHERS	7/7/2014
CHECKED BY		
PRINT DATE		7/28/2014
CONFIG.	Default	
COMMENTS:		



DWG: 1009228 540 RPM PTO SHAFT OPTION

PROPRIETARY AND CONFIDENTIAL
 THE INFORMATION CONTAINED IN THIS DRAWING IS THE SOLE PROPERTY OF DALTON AG. ANY REPRODUCTION IN PART OR AS A WHOLE WITHOUT THE WRITTEN PERMISSION OF DALTON AG IS PROHIBITED.

SIZE	SHEET TITLE:	REV
A	Sheet1	A
SCALE: 1:10	SHEET 1 OF 1	

FOR PARTS, CALL 1.800.342.7498

1000 PTO

4440854 1000 RPM PTO SHAFT

4440854 1000 RPM PTO SHAFT

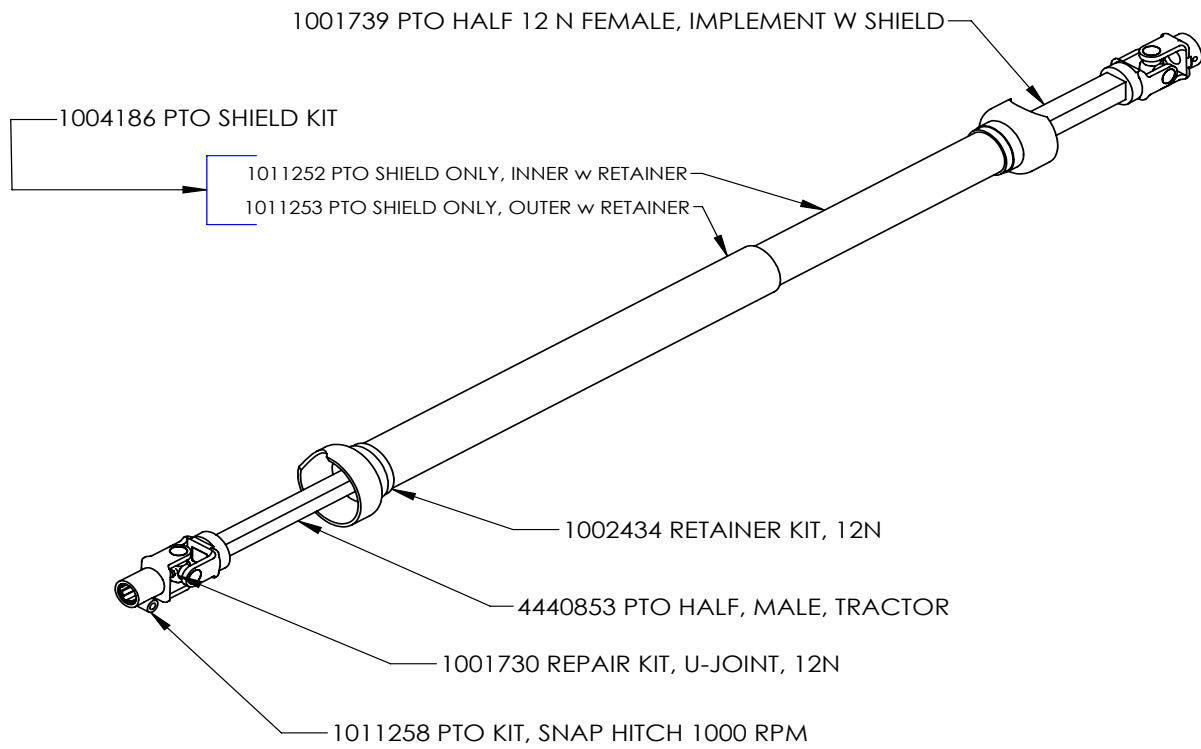

DRAWN BY	RICH SMOTHERS	7/7/2014
CHECKED BY		
PRINT DATE	12/24/2015	
CONFIG.	Default	



PROPRIETARY AND CONFIDENTIAL
THE INFORMATION CONTAINED IN THIS DRAWING IS THE SOLE PROPERTY OF CMC-DALTON AG. ANY REPRODUCTION IN PART OR AS A WHOLE WITHOUT THE WRITTEN PERMISSION OF CMC-DALTON AG IS PROHIBITED.

COMMENTS:

DWG: 4440854 1000 RPM PTO SHAFT

SIZE	SHEET TITLE:	REV
A	Sheet1	A

FOR PARTS, CALL 1.800.342.7498

SCALE: 1:10 SHEET 1 OF 1

WALKING BEAM, NO BRAKES 5 TON

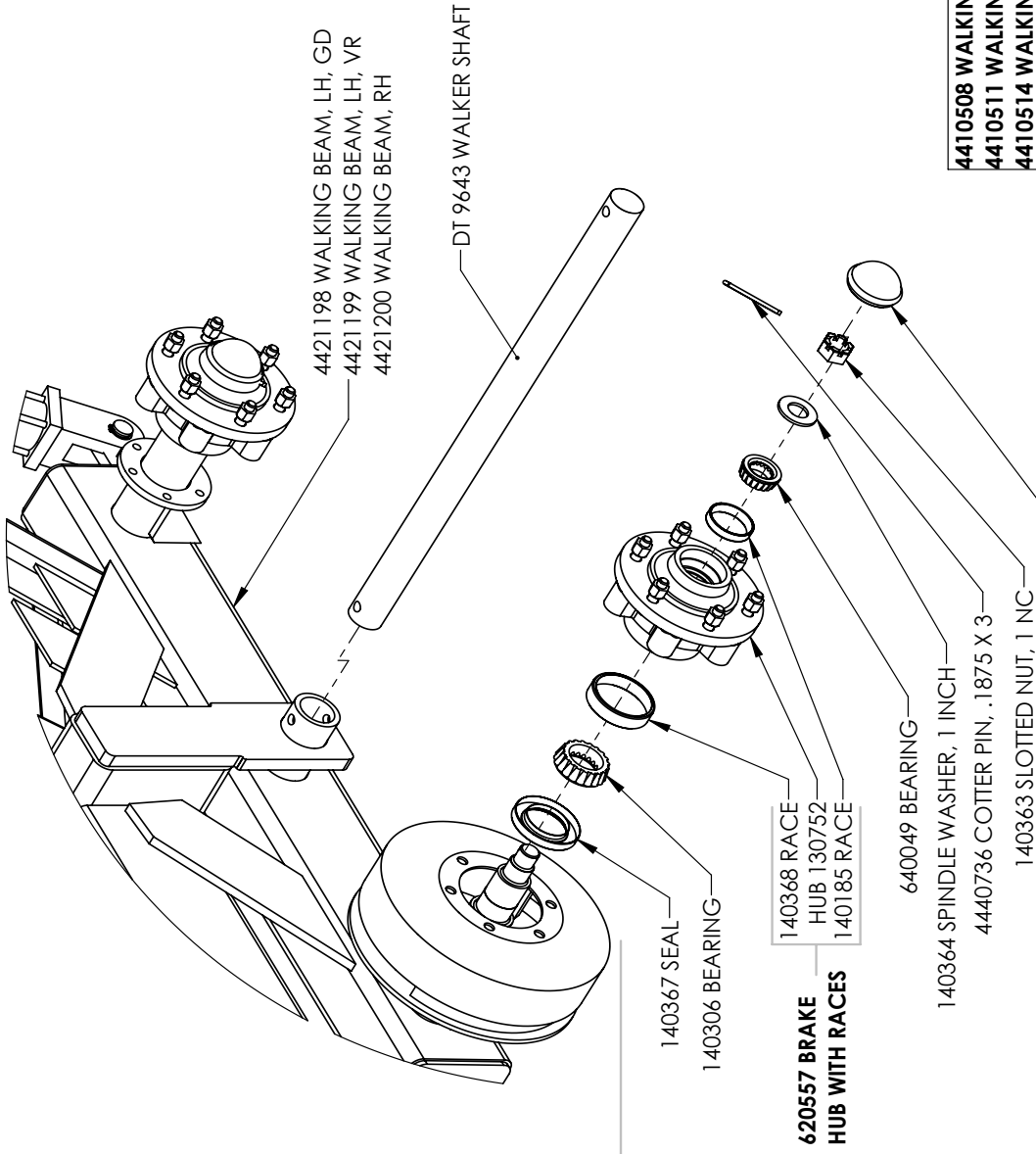

4410508 WALKING BEAM ASSEMBLY, NO BRAKES, RH
4410511 WALKING BEAM ASSEMBLY, NO BRAKES, LH
4410514 WALKING BEAM ASSEMBLY, NO BRAKES, LH, GD



 A C P B O D U C T S
 602 E. VAN BUREN ST., LENOX, IA 50851
 DWG: WALK BEAM NO BRAKES, 5 TON

SIZE	SHEET TITLE:	REV
A	5 TON NO BRAKES	
SCALE: 1:96		SHEET 1 OF 1

DRAWN BY	lLong	10/20/2017
CHECKED BY		
PRINT DATE		10/25/2017
CONFIG.	WALKING BEAM NO BRAKES	
COMMENTS:		

4410087 HUB COMPLETE

PROPRIETARY AND CONFIDENTIAL
THE INFORMATION CONTAINED IN THIS DRAWING IS THE SOLE PROPERTY OF DALTON AG. ANY REPRODUCTION IN PART OR AS A WHOLE WITHOUT THE WRITTEN PERMISSION OF DALTON AG IS PROHIBITED.

C:_EPDM_Vault\Spreadser\MOBILITY\ms assemblies\

5	4	3	2	1
---	---	---	---	---

WALKING BEAM, 2 WHEEL BRAKES 5 TON

ASSEMBLY

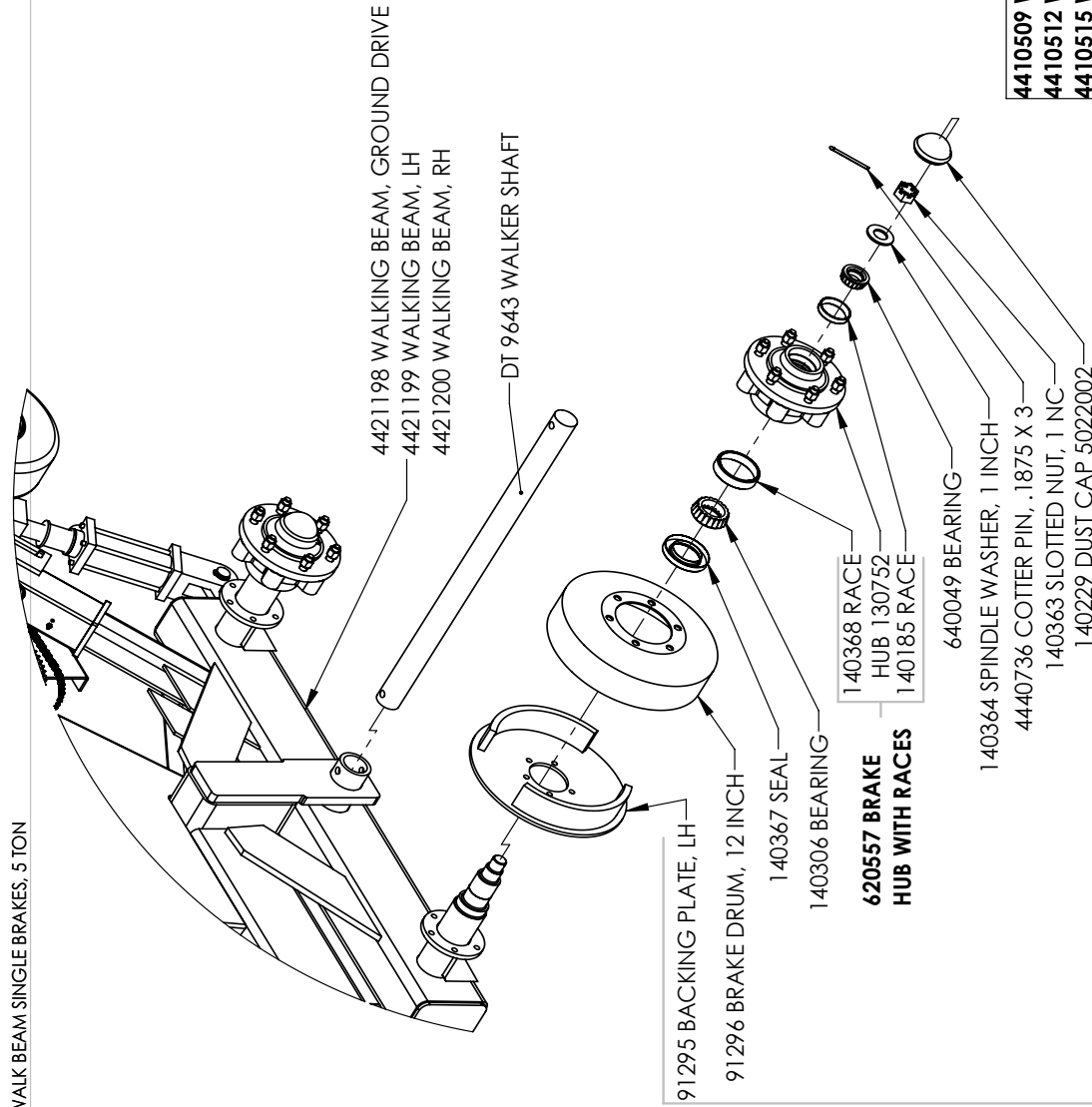

4410509 WALKING BEAM ASSEMBLY, SINGLE BRAKES, RH
4410512 WALKING BEAM ASSEMBLY, SINGLE BRAKES, LH
4410515 WALKING BEAM ASSEMBLY, SINGLE BRAKES, LH, GD

DRAWN BY	lLong	10/20/2017
CHECKED BY		
PRINT DATE	10/25/2017	
CONFIG.	WALKING BEAM SINGLE BRAKES	
COMMENTS:		

4410087 HUB COMPLETE

PROPRIETARY AND CONFIDENTIAL
THE INFORMATION CONTAINED IN THIS DRAWING IS THE SOLE PROPERTY OF DALTON AG. ANY REPRODUCTION IN PART OR AS A WHOLE WITHOUT THE WRITTEN PERMISSION OF DALTON AG IS PROHIBITED.

SCALE: 1:96	SHEET 1 OF 1
SIZE SHEET TITLE: A 5 TON SINGLE BRAKE WALK BEAM	REV
DWG: WALK BEAM SINGLE BRAKES, 5 TON	

WALKING BEAM, 4 WHEEL BRAKES 5 TON

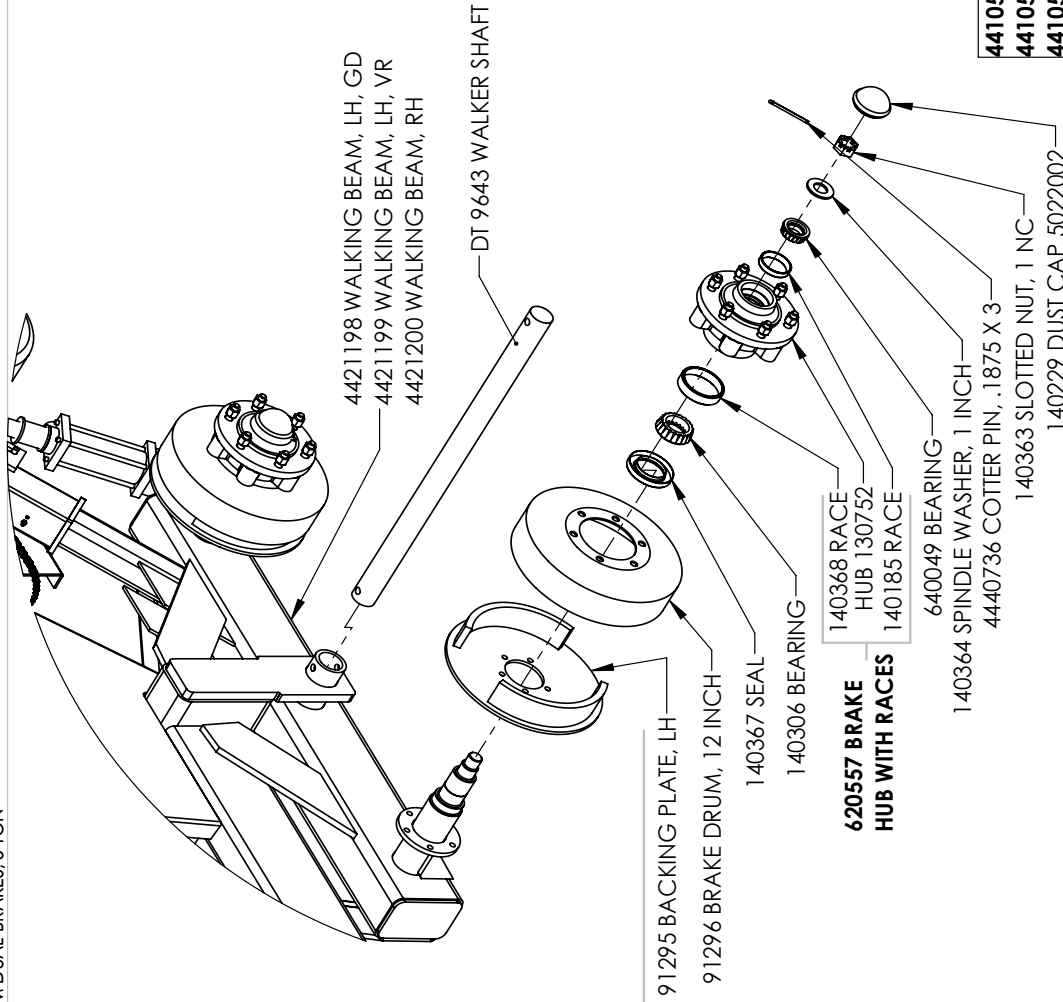

4410510 WALKING BEAM ASSEMBLY, DUAL BRAKES, RH
 4410513 WALKING BEAM ASSEMBLY, DUAL BRAKES, LH
 4410516 WALKING BEAM ASSEMBLY, DUAL BRAKES, LH, GD

4410087 HAB COMPLETE		DRAWN BY	lLong	10/20/2017
<p>PROPRIETARY AND CONFIDENTIAL THE INFORMATION CONTAINED IN THIS DRAWING IS THE SOLE PROPERTY OF DALTON AG. ANY REPRODUCTION IN PART OR AS A WHOLE WITHOUT THE WRITTEN PERMISSION OF DALTON AG IS PROHIBITED.</p> <p>C:_EPDM_Vault\Spreeder\MOBILITY\ms assemblies\</p>		CHECKED BY		
		PRINT DATE	10/25/2017	
		CONFIG.	WALK BEAM DUAL BRAKES	
COMMENTS:				
<p>DWG: WALK BEAM DUAL BRAKES, 5 TON</p> <p>SIZE SHEET TITLE: 5 TON DUAL BRAKES WALK BEAM</p> <p>SCALE: 1:96</p>		<p>REV</p> <p>SHEET 1 OF 1</p>		

5	4	3	2	1
---	---	---	---	---

WALKING BEAM, 2 WHEEL BRAKES 6 & 8 TON

ASSEMBLY

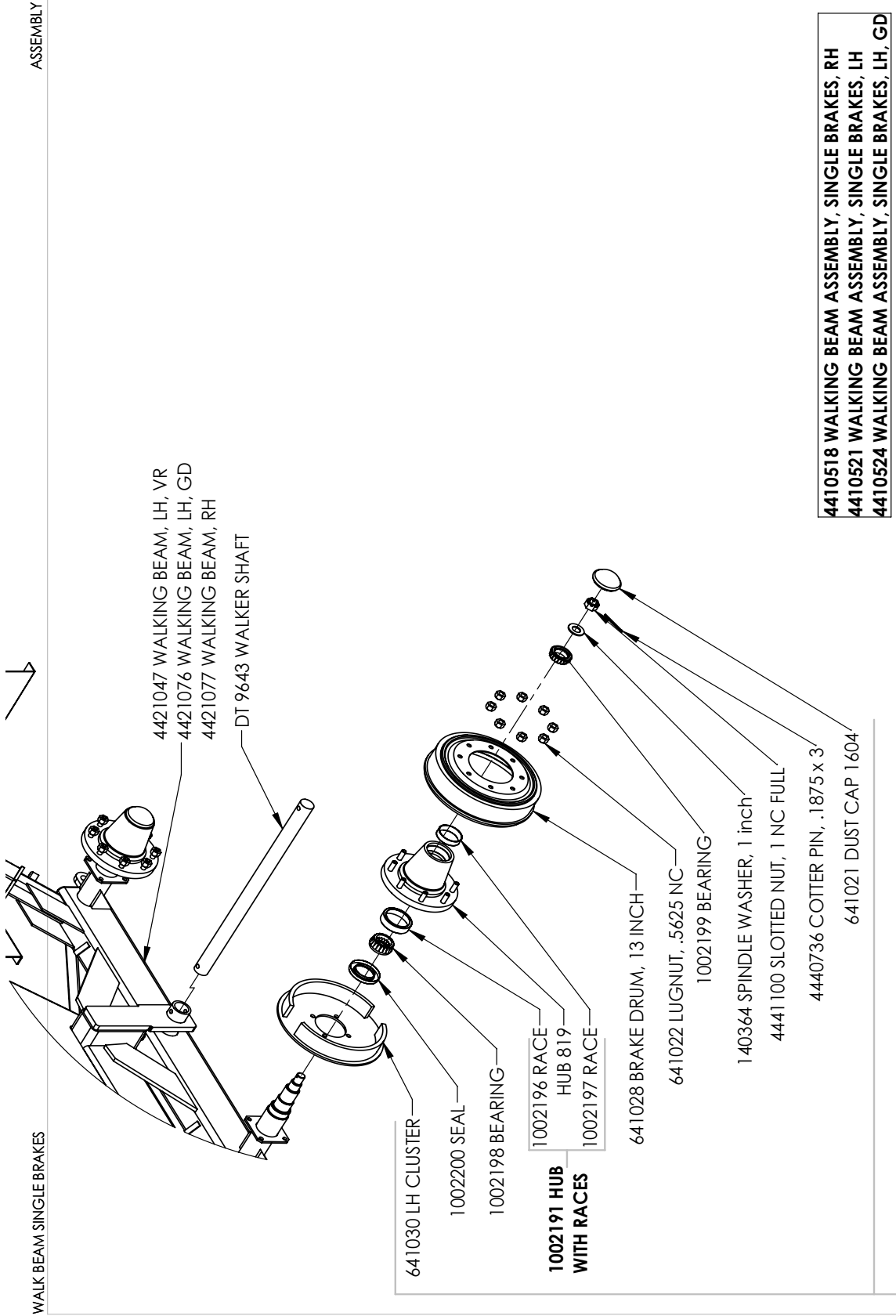

WALK BEAM SINGLE BRAKES

4410518 WALKING BEAM ASSEMBLY, SINGLE BRAKES, RH
4410521 WALKING BEAM ASSEMBLY, SINGLE BRAKES, LH
4410524 WALKING BEAM ASSEMBLY, SINGLE BRAKES, LH, GD

1002164 HUB ASSEMBLY COMPLETE	DRAWN BY	LLong	4/25/2017
<p>PROPRIETARY AND CONFIDENTIAL</p> <p>THE INFORMATION CONTAINED IN THIS DRAWING IS THE SOLE PROPERTY OF DALTON AG. ANY REPRODUCTION IN PART OR AS A WHOLE WITHOUT THE WRITTEN PERMISSION OF DALTON AG IS PROHIBITED.</p>	CHECKED BY		
	PRINT DATE	10/25/2017	
	CONFIG.	WALK BEAM SINGLE BRAKES	
	COMMENTS:		
	DWG:	WALK BEAM SINGLE BRAKES	
	SIZE	SHEET TITLE: 6 & 8 TON SINGLE BRAKES	
	SCALE:	1:96	SHEET 1 OF 1

C:_EPDM_Vault\Spreader\MOBILITY\ms assemblies\ 5 4 3 2 1

WALKING BEAM, 4 WHEEL BRAKES 6 & 8 TON

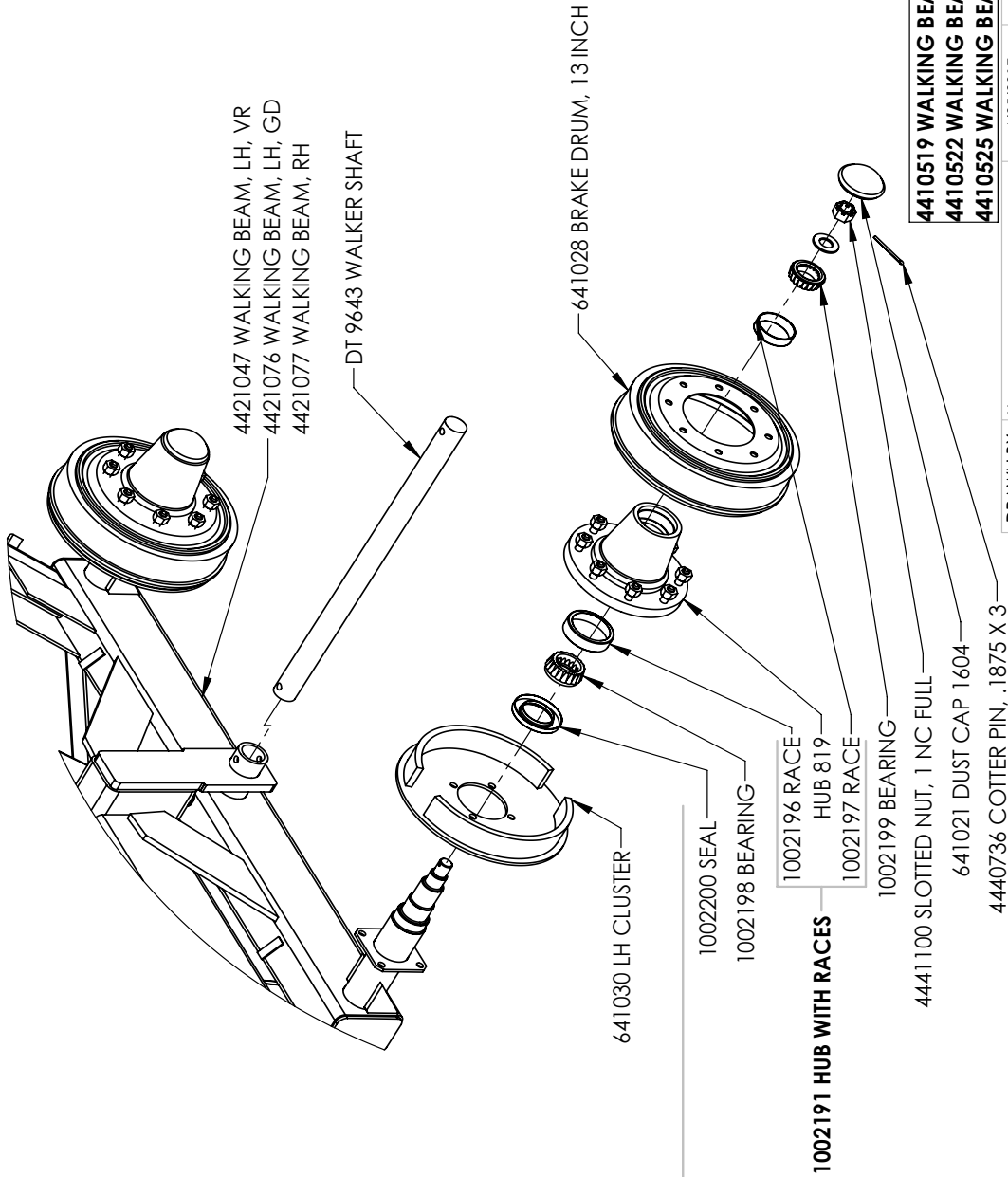

4410519 WALKING BEAM ASSEMBLY, DUAL BRAKES, RH
4410522 WALKING BEAM ASSEMBLY, DUAL BRAKES, LH
4410525 WALKING BEAM ASSEMBLY, DUAL BRAKES, LH, GD

DRAWN BY	lLong	4/25/2017
CHECKED BY		
PRINT DATE	10/25/2017	
CONFIG.	WALK BEAM DUAL BRAKES	
COMMENTS:		
DWG: WALK BEAM DUAL BRAKES		



1002194 HUB ASSEMBLY, COMPLETE

PROPRIETARY AND CONFIDENTIAL
THE INFORMATION CONTAINED IN THIS DRAWING IS THE SOLE PROPERTY OF DALTON AG. ANY REPRODUCTION IN PART OR AS A WHOLE WITHOUT THE WRITTEN PERMISSION OF DALTON AG IS PROHIBITED.

SIZE	A	REV	
SHEET TITLE:	6 & 8 TON DUAL BRAKES		
SCALE:	1:96	SHEET	1 OF 1

C:_EPDM_Yaull\Spreader\MOBILITY\ms assemblies\	3	2	1
	4		

GROUND DRIVE ASSEMBLY

SUB-ASSEMBLY

GROUND DRIVE ASSEMBLY BOOK ONLY

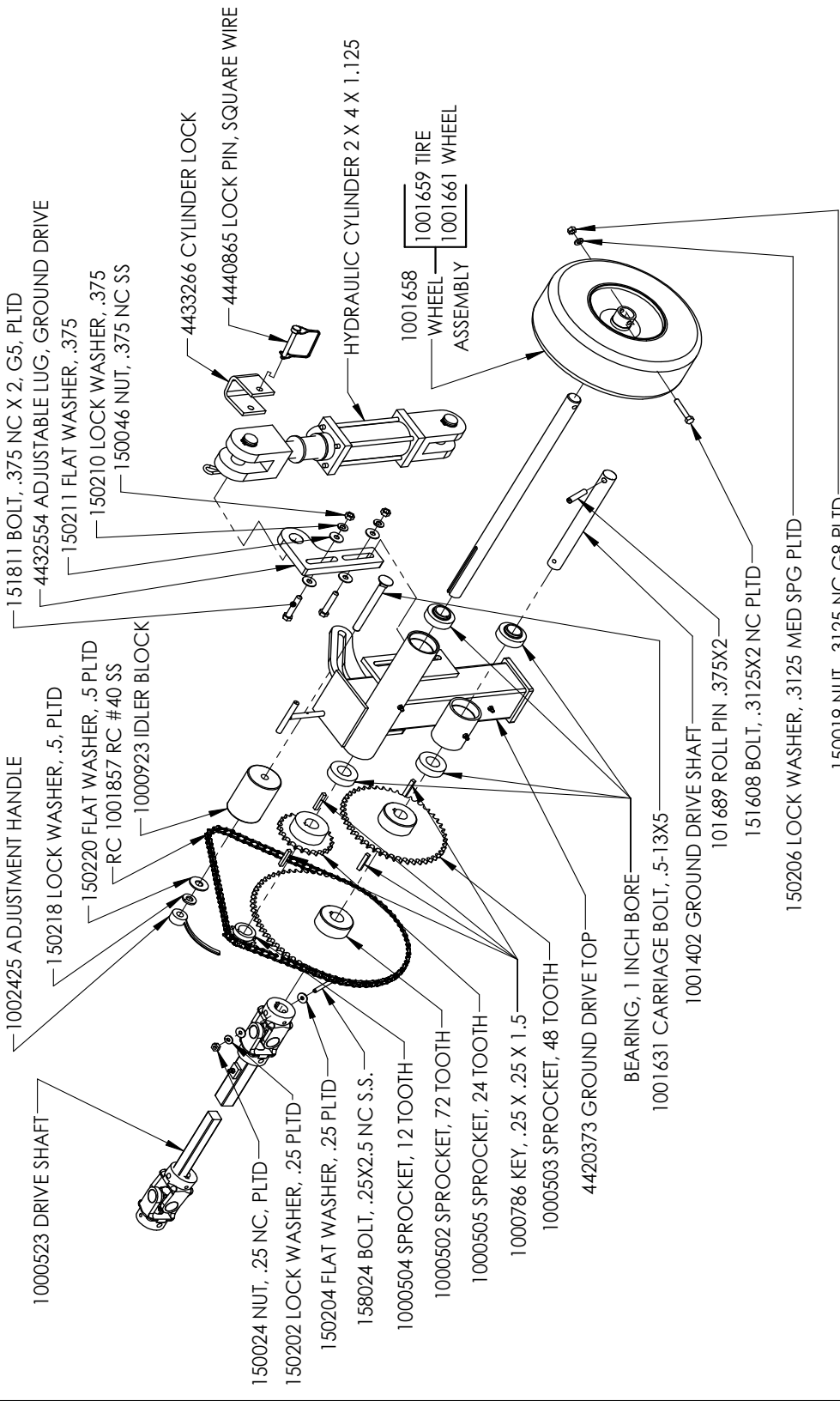

- 1000523 DRIVE SHAFT
- 1002425 ADJUSTMENT HANDLE
- 150218 LOCK WASHER, .5, PLTD
- 150220 FLAT WASHER, .5 PLTD
- RC 1001857 RC #40 SS
- 1000923 IDLER BLOCK
- 150024 NUT, .25 NC, PLTD
- 150202 LOCK WASHER, .25 PLTD
- 150204 FLAT WASHER, .25 PLTD
- 158024 BOLT, .25X2.5 NC S.S.
- 1000504 SPROCKET, 12 TOOTH
- 1000502 SPROCKET, 72 TOOTH
- 1000505 SPROCKET, 24 TOOTH
- 1000786 KEY, .25 X .25 X 1.5
- 1000503 SPROCKET, 48 TOOTH
- 4420373 GROUND DRIVE TOP
- BEARING, 1 INCH BORE
- 1001631 CARRIAGE BOLT, .5-13X5
- 1001402 GROUND DRIVE SHAFT
- 101689 ROLL PIN .375X2
- 151608 BOLT, .3125X2 NC PLTD
- 150206 LOCK WASHER, .3125 MED SPG PLTD
- 150019 NUT, .3125 NC G8 PLTD
- 1001658 WHEEL ASSEMBLY
- 1001659 TIRE
- 1001661 WHEEL
- HYDRAULIC CYLINDER 2 X 4 X 1.125
- 4433266 CYLINDER LOCK
- 4440865 LOCK PIN, SQUARE WIRE
- 151811 BOLT, .375 NC X 2, G5, PLTD
- 4432554 ADJUSTABLE LUG, GROUND DRIVE
- 150211 FLAT WASHER, .375
- 150210 LOCK WASHER, .375
- 150046 NUT, .375 NC SS

DRAWN BY Llong	5/2/2017	 A G P R O D U C T S 602 E. VAN BUREN ST., LENOX, IA 50851	
CHECKED BY			
PRINT DATE	5/2/2017		
CONFIG. Default			
COMMENTS:		DWG: GROUND DRIVE ASSEMBLY BOOK ONLY	
PROPRIETARY AND CONFIDENTIAL THE INFORMATION CONTAINED IN THIS DRAWING IS THE SOLE PROPERTY OF DALTON AG. ANY REPRODUCTION IN PART OR AS A WHOLE WITHOUT THE WRITTEN PERMISSION OF DALTON AG IS PROHIBITED.		SIZE (SHEET TITLE): A 6 AND 8 TON TANDEM	REV
		SCALE: 1:10	SHEET 1 OF 1

FRONT TANK ASSEMBLY

FRONT TANK ASSEMBLY

FRONT TANK ASSEMBLY

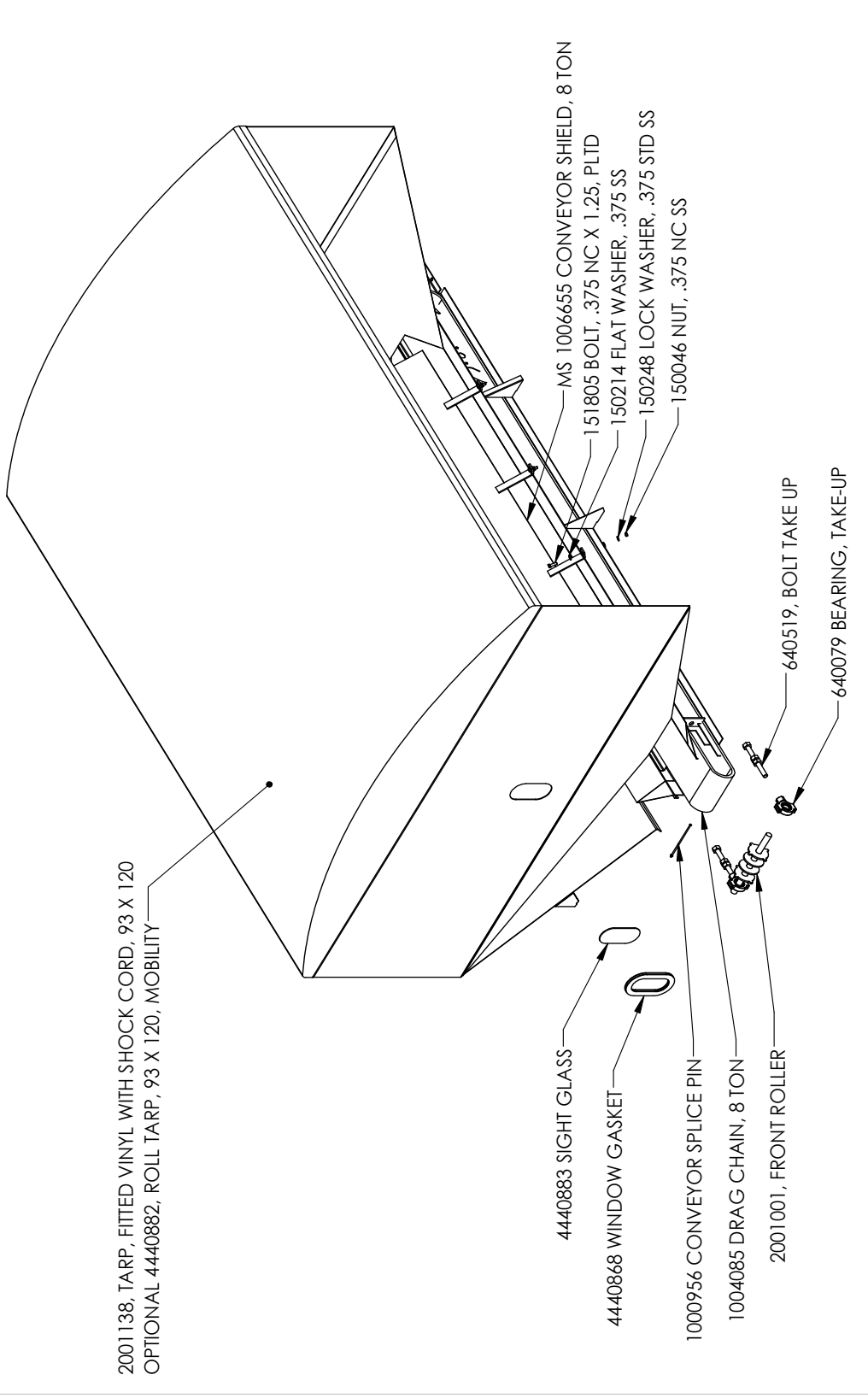

DRAWN BY: Llong CHECKED BY: PRINT DATE: 4/26/2017 CONFIG: FRONT TANK ASSEMBLY, ROW CROP COMMENTS:	4/26/2017	2	3	4	5
Dalton A G P R O D U C T S 602 E. VAN BUREN ST., LENOX, IA 50851		DWG: FRONT TANK ASSEMBLY			
SIZE SHEET TITLE: FRONT TANK ASSEMBLY		REV			
A		SCALE: 1:24			
PROPRIETARY AND CONFIDENTIAL THE INFORMATION CONTAINED IN THIS DRAWING IS THE SOLE PROPERTY OF DALTON AG. ANY REPRODUCTION IN PART OR AS A WHOLE WITHOUT THE WRITTEN PERMISSION OF DALTON AG IS PROHIBITED.		C:\EPDM_Vault\Spreader\MOBILITY\ms assemblies\			
SHEET 1 OF 1		1			

REAR AREA ASSEMBLY

REAR AREA ASSEMBLY

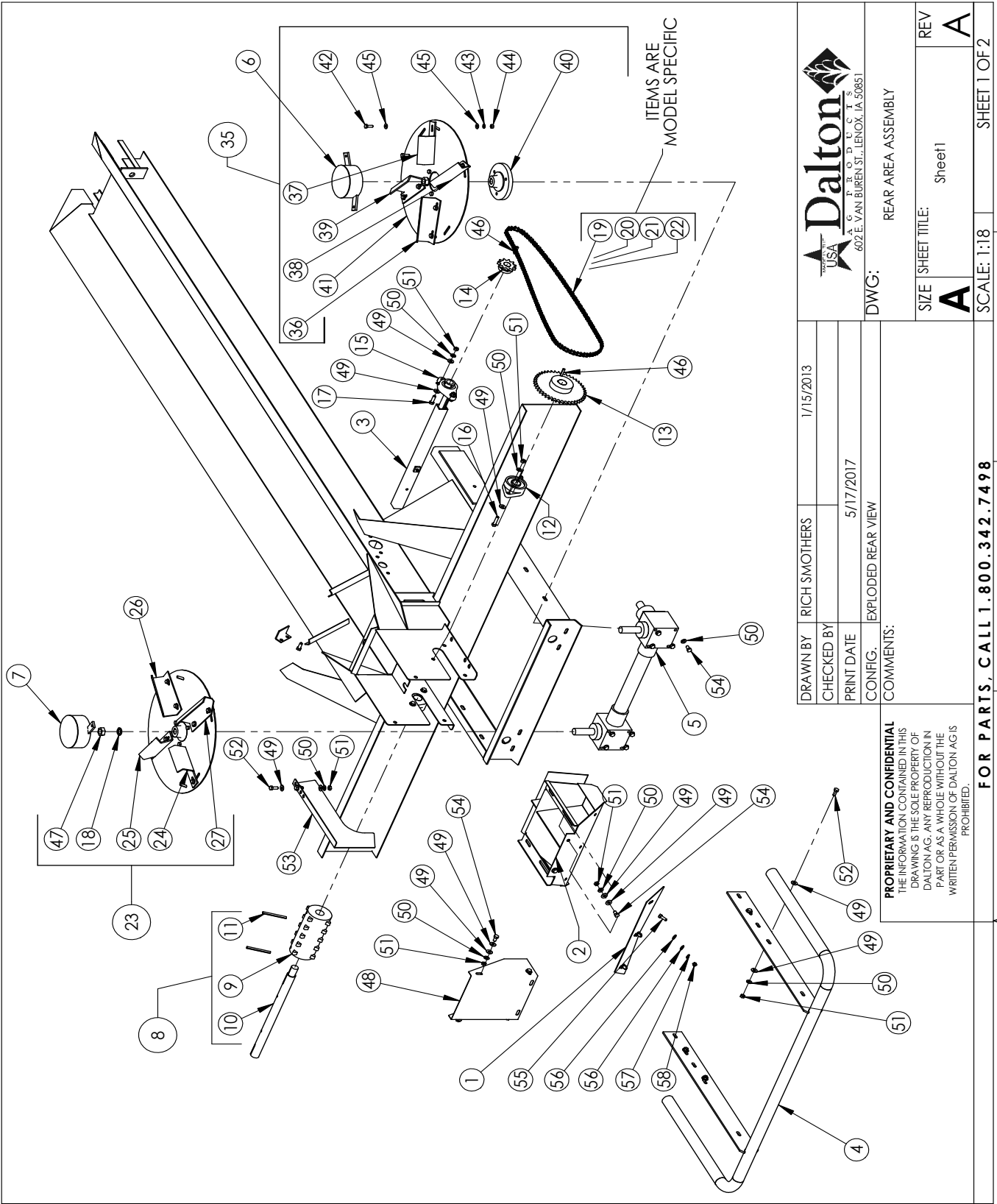

REAR AREA ASSEMBLY

#	PART NUMBER	Q
1	MS 1001501 DIVIDER	1
2	MS 1001379 DIVIDER WELDMENT	1
3	2001108 WLD, FEMALE 0.5, DRIVE SHAFT	1
4	1008033 BUMPER WELDMENT	1
5	1003737 GEAR BOX SET	1
6	1001717 DISC CAP WELDMENT R.H.	1
7	1001716 DISC CAP WELDMENT L.H	1
8	1000838 DRIVE SPROCKET ASSEMBLY	1
9	1000684 CAST SPROCKET, MACHINED	1
10	1000644 SPROCKET SHAFT	1
11	158035 ROLL PIN .3125 x 3.5	2
12	1000646 BEARING, 1.25 BORE 2-BOLT FLANGE	2
13	1000507 SPROCKET 50B36	1
14	1000506 SPROCKET, 50B12	1
15	640034 BEARING, 1 INCH BORE 2-BOLT	1
16	151806 BOLT, .375 NC x 1.5, G5, PLTD	4
17	151805 BOLT, .375 NC x 1.25, PLTD	3
18	150226 LOCK WASHER, .75, PLTD	2
19	4432166-108 STAINLESS #50 CHAIN, 108 PITCH w CONNECTOR (8 TON GROUND DRIVE)	1
20	4432166-125 STAINLESS #50 CHAIN, 125 PITCH w CONNECTOR (6 TON GROUND DRIVE)	1
21	641318 LINK	1
22	641319 1/2 LINK (OFFSET) (6 TON)	1
23	1003733 DISTRIBUTOR DISC ASSEMBLY, L.H.	1
24	MS 1001925 4.375 DISTRIBUTOR BLADE, LEFT	1
25	MS 1001927 DISTRIBUTOR BLADE, 5.5, LEFT	1
26	MS 1001719 7 INCH DISTRIBUTOR BLADE, LEFT	1
27	MS 1001705 EXTRA LONG DISTRIBUTOR BLADE, 8, LEFT	1
28	1003727 DISTRIBUTOR DISC	1
29	1003709-VR SPINNER HUB, VARIABLE RATE, MACHINED	1
30	158053, LOCK WASHER, .3125 SS	12
31	158054 WASHER, .3125 SS	16
32	151615 BOLT, .3125 x .75 SS	10
33	150007 NUT, .3125 NC SS	12
34	151610 .3125x1 NC SS	2
35	1003734 DISTRIBUTOR DISC ASSEMBLY, RH	1
36	MS 1001718 7 INCH DISTRIBUTOR BLADE, RIGHT	1
37	MS 1001924 4.375 DISTRIBUTOR BLADE, RIGHT	1

#	PART NUMBER	Q
38	MS 1001662 EXTRA LONG DISTRIBUTOR BLADE, 8, RIGHT	1
39	MS 1001926 DISTRIBUTOR BLADE, 5.5, RIGHT	1
40	1003709 SPINNER HUB, STANDARD	1
41	1003727 DISTRIBUTOR DISC	1
42	151610 .3125x1 NC SS	12
43	158053, LOCK WASHER, .3125 SS	12
44	150007 NUT, .3125 NC SS	12
45	158054 WASHER, .3125 SS	16
46	641653 KEY, .25 x .25 x 1.25	2
47	150124 NUT, NF, SS	2
48	1001390 TROUGH EXTENSION BACK	1
49	150214 FLAT WASHER, .375 SS	32
50	150248 LOCK WASHER, .375 STD SS	26
51	150046 NUT, .375 NC SS	18
52	151804 BOLT .375 x 1 NC SS	5
53	MS 2001004 PARTER PLATE	1
54	151834 BOLT .375 x .75 NC SS	14
55	151610 .3125x1 NC SS	3
56	158054 WASHER, .3125 SS	6
57	158053, LOCK WASHER, .3125 SS	3
58	150007 NUT, .3125 NC SS	3

****1004466 DISTRIBUTOR BLADE SET
INCLUDES BOTH RIGHT SIDE
AND LEFT SIDE BLADES.**

PROPRIETARY AND CONFIDENTIAL THE INFORMATION CONTAINED IN THIS DRAWING IS THE SOLE PROPERTY OF DALTON AG. ANY REPRODUCTION IN PART OR AS A WHOLE WITHOUT THE WRITTEN PERMISSION OF DALTON AG IS PROHIBITED.	DRAWN BY	RICH SMOTHERS	 <p align="center">www.DaltonAg.com</p>
	CHECKED BY		
	PRINT DATE		
	CONFIG.		
	COMMENTS:		DWG: REAR AREA ASSEMBLY SIZE A SHEET TITLE: Sheet2 REV A
FOR PARTS, CALL 1.800.342.7498			SCALE: 1:20 SHEET 2 OF 2

GATE JACK ASSEMBLY

4410472, GATE JACK ASSEMBLY

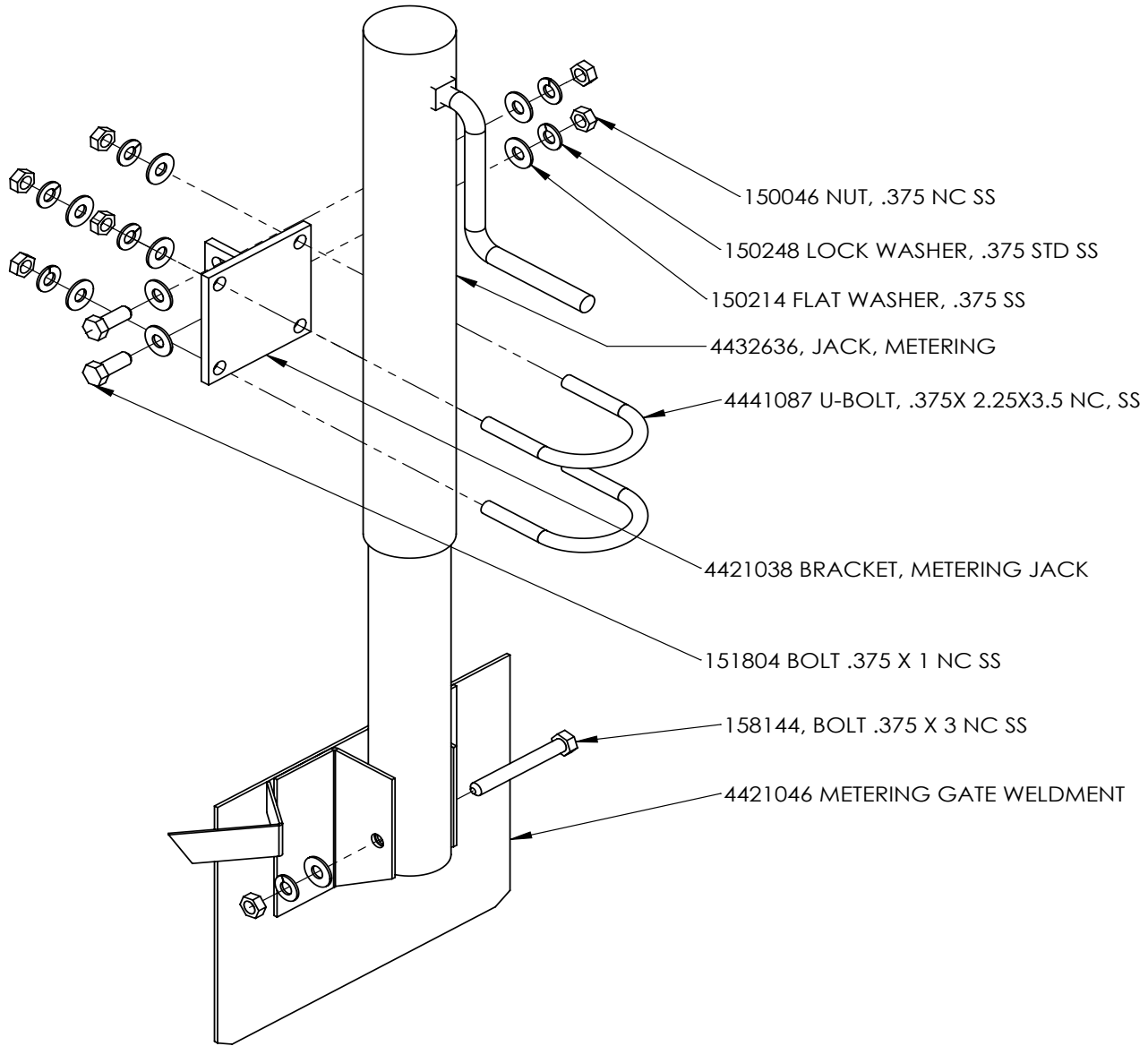

DRAWN BY	RICH SMOTHERS	3/30/2017
CHECKED BY		
PRINT DATE	10/19/2017	
CONFIG.	Default	
COMMENTS:		



DWG: GATE JACK ASSEMBLY

PROPRIETARY AND CONFIDENTIAL
 THE INFORMATION CONTAINED IN THIS DRAWING IS THE SOLE PROPERTY OF DALTON AG. ANY REPRODUCTION IN PART OR AS A WHOLE WITHOUT THE WRITTEN PERMISSION OF DALTON AG IS PROHIBITED.

SIZE	SHEET TITLE:	REV
A	Sheet1	A

FOR PARTS, CALL 1.800.342.7498

SCALE: 1:4 SHEET 1 OF 1

IDLER MOUNT, CHAIN BELT

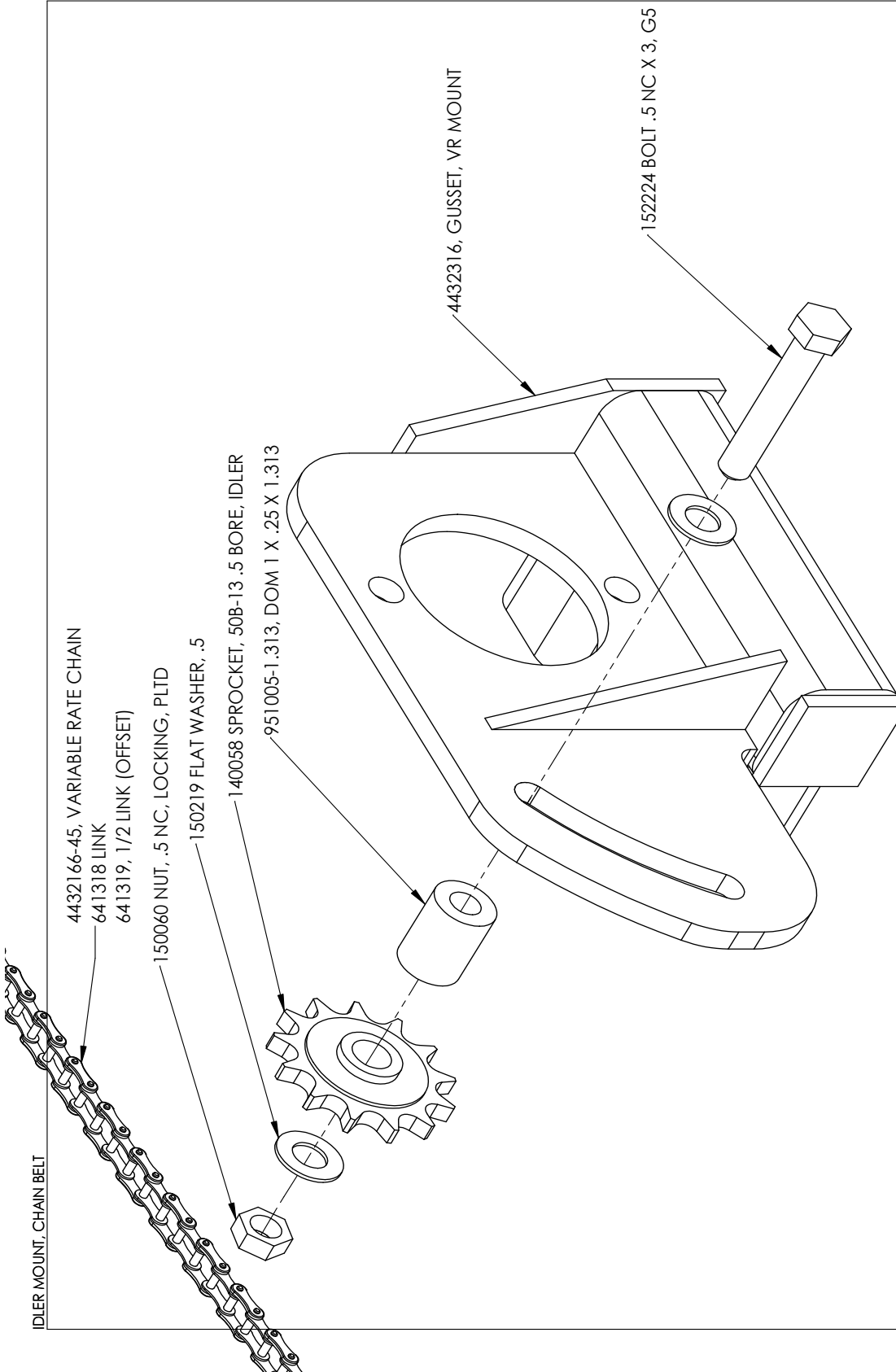

DRAWN BY Llong	DATE 3/30/2017	 A G P R O D U C T S 602 E. VAN BUREN ST., LENOX, IA 50851	
CHECKED BY			
PRINT DATE 5/2/2017		DWG: IDLER MOUNT, CHAIN BELT	
CONFIG: Default			
COMMENTS:		SIZE (SHEET TITLE): A IDLER, DRIVE CHAIN, GD REV	
PROPRIETARY AND CONFIDENTIAL THE INFORMATION CONTAINED IN THIS DRAWING IS THE SOLE PROPERTY OF DALTON AG. ANY REPRODUCTION IN PART OR AS A WHOLE WITHOUT THE WRITTEN PERMISSION OF DALTON AG IS PROHIBITED.		SCALE: 1:2	SHEET 1 OF 1

5	4	3	2	1

1003737, DISTRIBUTOR GEAR BOX

ITEM	PART #	DESCRIPTION	QTY
1	1003735	BOX ASSEMBLY, RH	1
2	1000938	PLUG, SOFT	2
3	1000932	BEARING	8
4	1002426	GEAR	2
5	1000936	HOUSING, RH	1
6	1006856	OIL PLUG	2
7	1000935	KEY, WOODRUFF	2
8	1003730	SHAFT, TAPERED	1
9	1000933	RETAINER RING	5
10	1000931	RETAINER RING	8
11	1000930	SEAL	3
12	1001206	TUBE ASSEMBLY	1
13	1000944	HOUSING BARREL	3
14	1000941	TUBE ASSEMBLY	1
15	1002417	SHAFT, TAPERED	1
16	1000945	PINION GEAR	2
17	1003736	BOX ASSEMBLY, LH	1
18	1003730	SHAFT, TAPERED	1
19	1000947	HOUSING, LH	1
20	1001205	BARREL ASSEMBLY	1
21	1000948	SHAFT & GEAR ASSEMBLY	1
22	1000940	GASKET	3
23	1000834	HHCS, 5/16-18 x 3/4"	12
24	1000836	LOCK WASHER, 5/16"	12
25	1003742	45 DEGREE GREASE ZERK	2

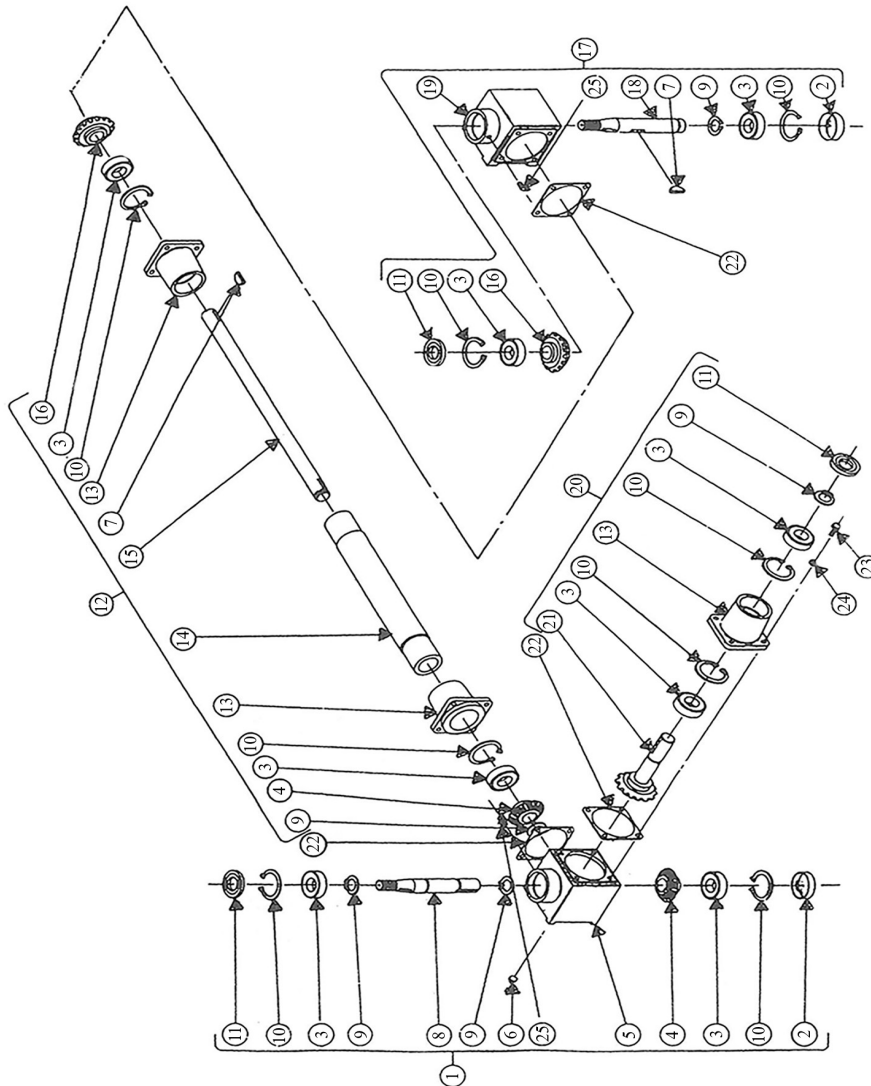

HYDRAULIC SPINNER GEAR BOX

ROW CROP HYD SPINNERS

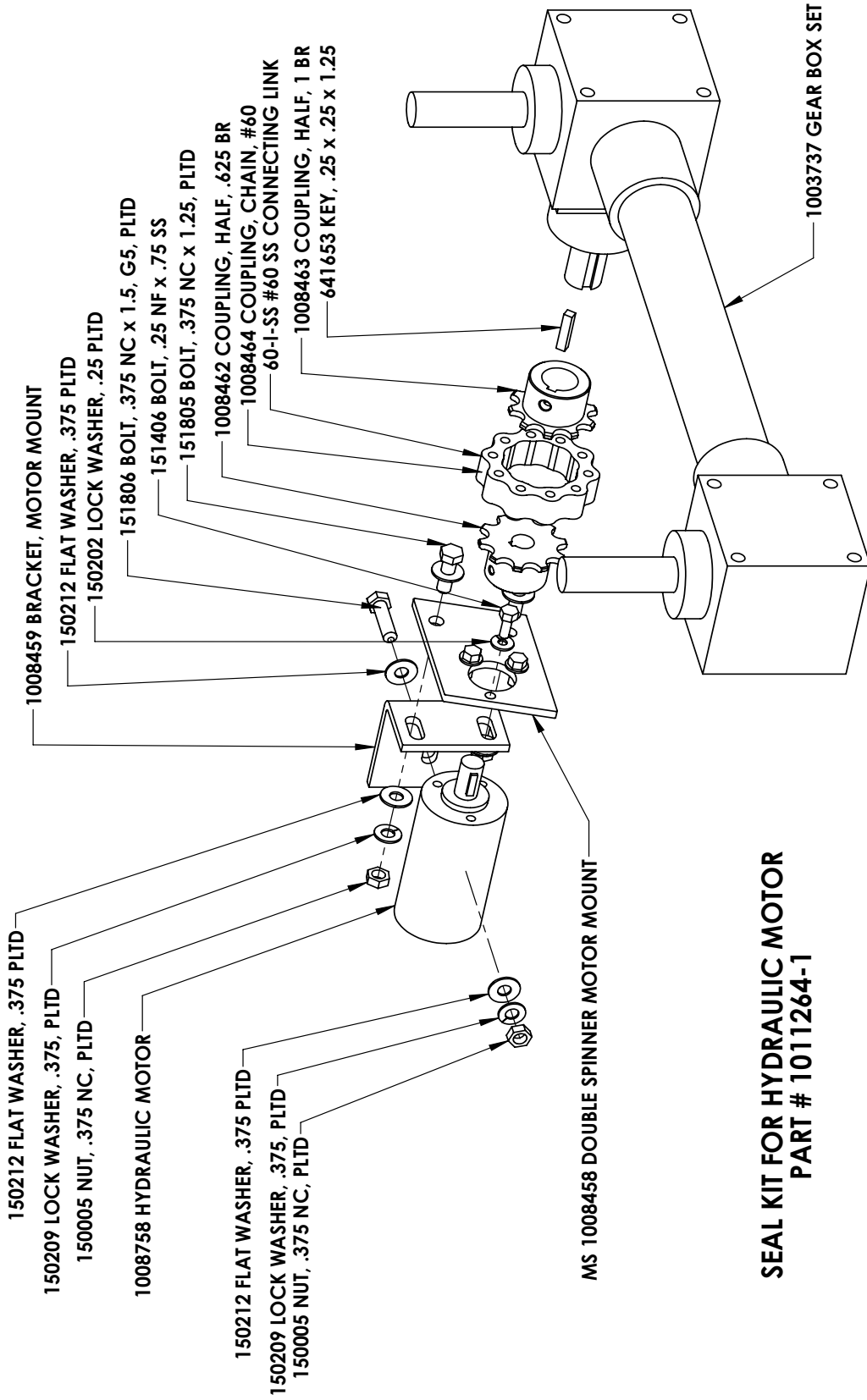

SEAL KIT FOR HYDRAULIC MOTOR PART # 1011264-1

DRAWN BY	RICH SMOTHERS	4/3/2013
CHECKED BY		
PRINT DATE	6/17/2016	
CONFIG.	Default	
COMMENTS:		



DWG: ROW CROP HYD SPINNERS

SIZE **A** SHEET TITLE: Sheet1 REV **A**

SCALE: 1:4 SHEET 1 OF 1

PROPRIETARY AND CONFIDENTIAL
 THE INFORMATION CONTAINED IN THIS DRAWING IS THE SOLE PROPERTY OF DALTON A.G. ANY REPRODUCTION IN PART OR AS A WHOLE WITHOUT THE WRITTEN PERMISSION OF DALTON A.G IS PROHIBITED.

FOR PARTS, CALL 1.800.342.7498

5 4 3 2 1

TRACTOR HYDRAULIC DRIVEN SPINNERS

TRACTOR HYDRAULIC DRIVEN SPINNERS, APRIL 2017

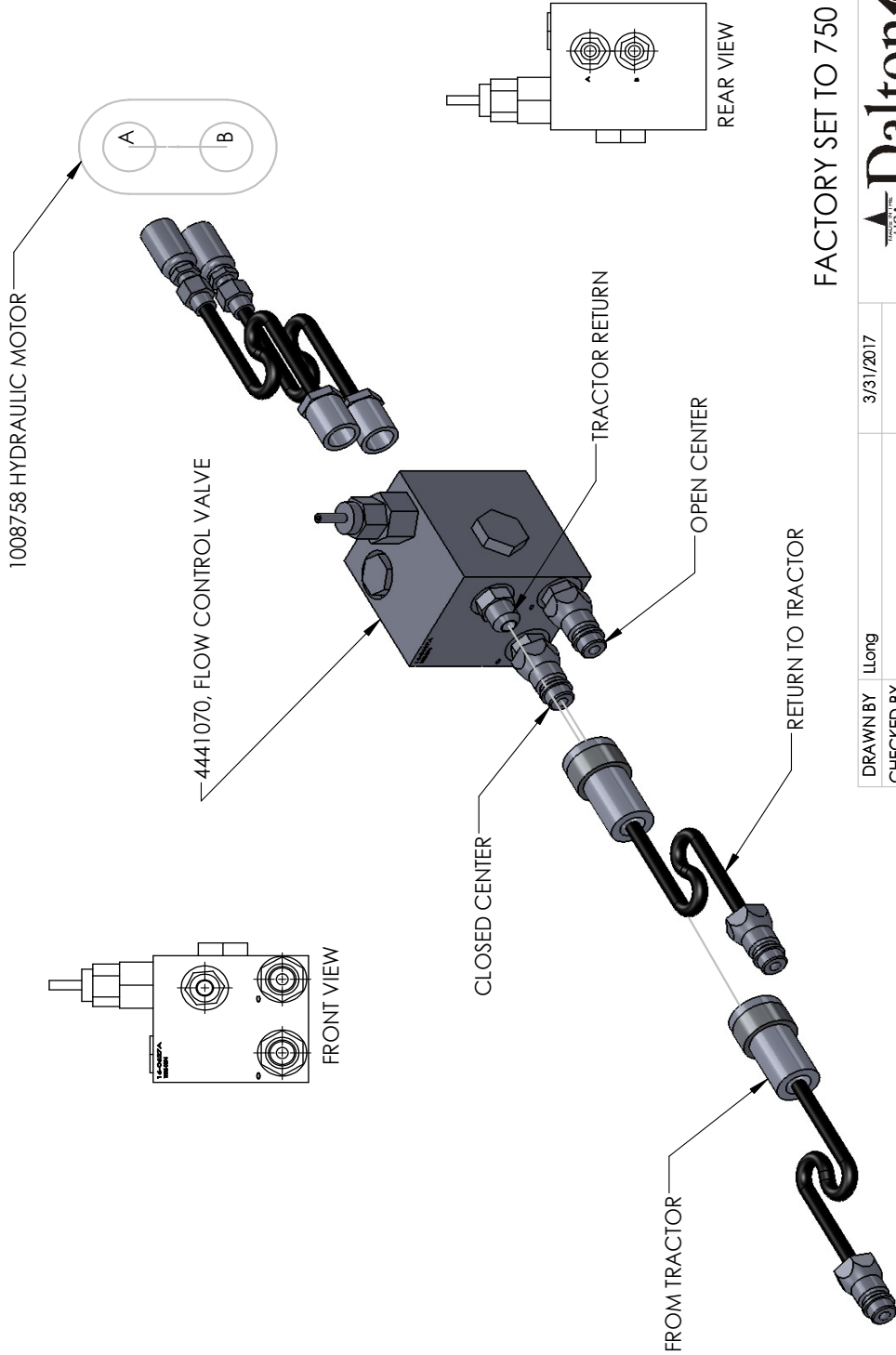

FACTORY SET TO 750 RPM

Dalton
 USA
 A G P R O D U C T S
 602 E. VAN BUREN ST., LENOX, IA 50851

DWG: TRACTOR HYDRAULIC DRIVEN SPINNERS, APRIL 2017

SIZE	A	SHEET TITLE:	SCHEMATIC	REV
SCALE:	1:4	SHEET 1 OF 1		1

DRAWN BY	Llong	3/31/2017
CHECKED BY		
PRINT DATE	5/1/2017	
CONFIG:	Default	
COMMENTS:		

PROPRIETARY AND CONFIDENTIAL
 THE INFORMATION CONTAINED IN THIS DRAWING IS THE SOLE PROPERTY OF DALTON AG. ANY REPRODUCTION IN PART OR AS A WHOLE WITHOUT THE WRITTEN PERMISSION OF DALTON AG IS PROHIBITED.

C:\EPDM_Vault\Spreeder\MOBILITY\MS Documents\MS MANUALS\RC 600 & 800\	3	2	1
	5		

DIGITAL READOUT

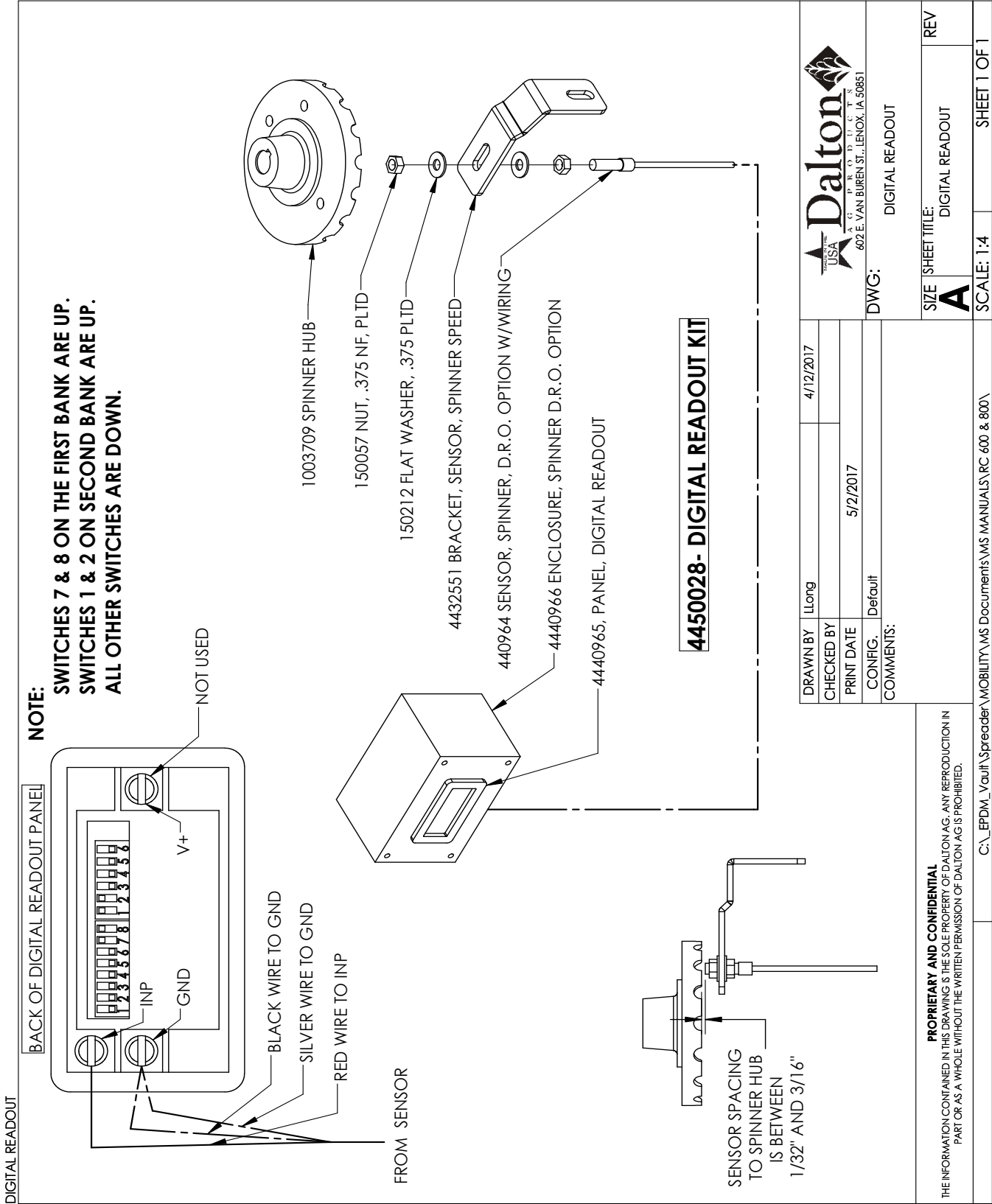

DRAWN BY Llong		4/12/2017
CHECKED BY		
PRINT DATE	5/2/2017	
CONFIG:	Default	
COMMENTS:		
DWG: DIGITAL READOUT		
SIZE (SHEET TITLE):	DIGITAL READOUT	REV
A		
SCALE: 1:4		SHEET 1 OF 1

PROPRIETARY AND CONFIDENTIAL
 THE INFORMATION CONTAINED IN THIS DRAWING IS THE SOLE PROPERTY OF DALTON AG. ANY REPRODUCTION IN PART OR AS A WHOLE WITHOUT THE WRITTEN PERMISSION OF DALTON AG IS PROHIBITED.

C:\EPDM_Vault\Spreader\MOBILITY MS Documents\MS MANUALS\RC 600 & 800\	3	2	1
5	4		

VARIABLE RATE CONTROL, ELECTRICAL PLAN

SCS 660 WITH MASTER SWITCH GRANULAR CONTROL SYSTEM

CONTROL CONSOLE W/ MASTER SWITCH
SCS 660: 063-0172-542

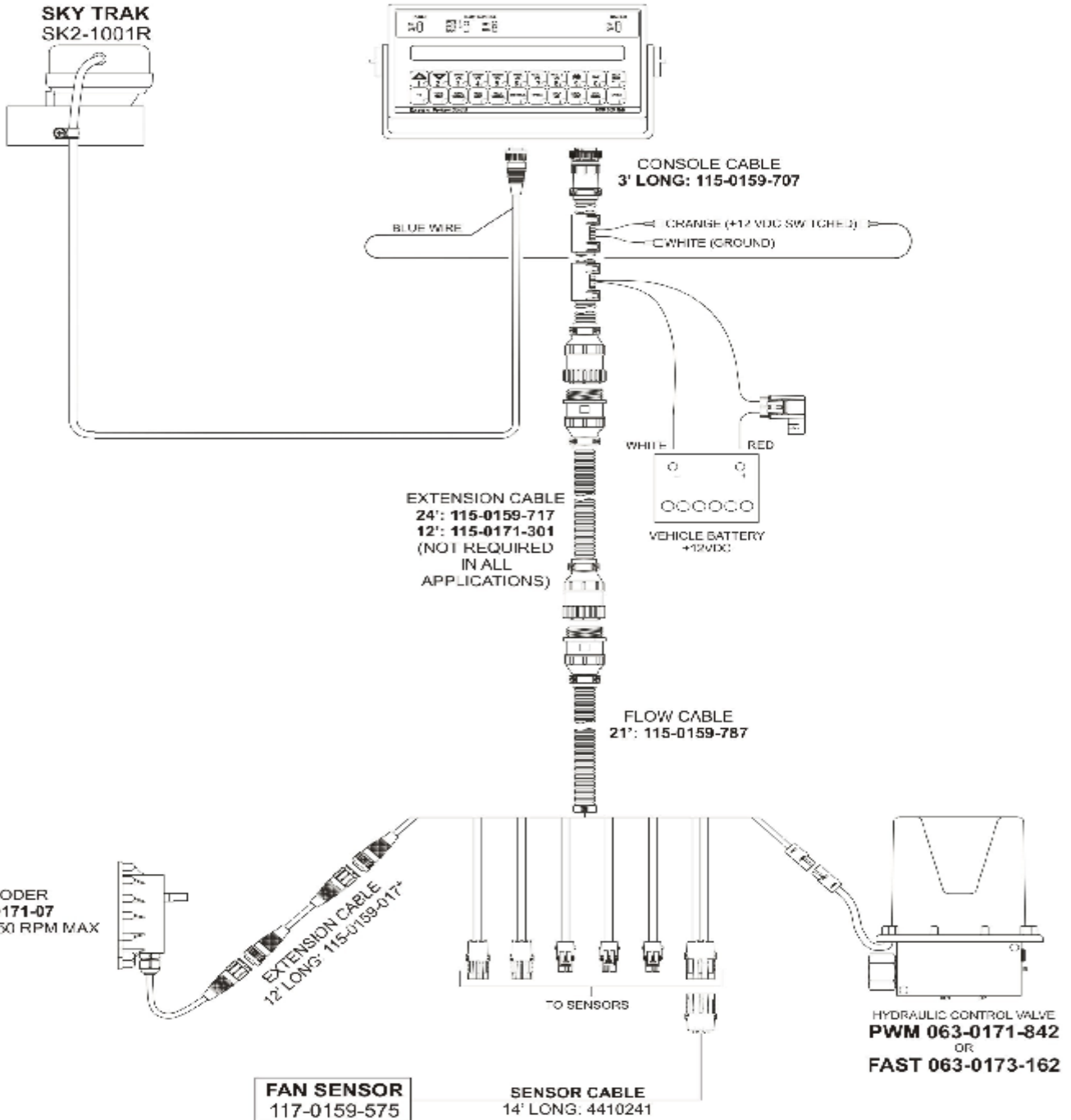

DRAWN BY	RICH SMOTHERS
CHECKED BY	
PRINT DATE	
CONFIG.	
COMMENTS:	



PROPRIETARY AND CONFIDENTIAL
THE INFORMATION CONTAINED IN THIS DRAWING IS THE SOLE PROPERTY OF CMC-DALTON AG. ANY REPRODUCTION IN PART OR AS A WHOLE WITHOUT THE WRITTEN PERMISSION OF CMC-DALTON AG IS PROHIBITED.

DWG: VARIABLE RATE CONTROL, ELECTRICAL PLAN

SIZE	SHEET TITLE:	REV
A	ELECTRICAL PLUMBING	A
SCALE: 1:10	SHEET 1 OF 1	

FOR PARTS, CALL 1.800.342.7498

VARIABLE RATE CONTROL, HYDRAULIC PLAN

VARIABLE RATE CONTROL, HYDRAULIC PLAN

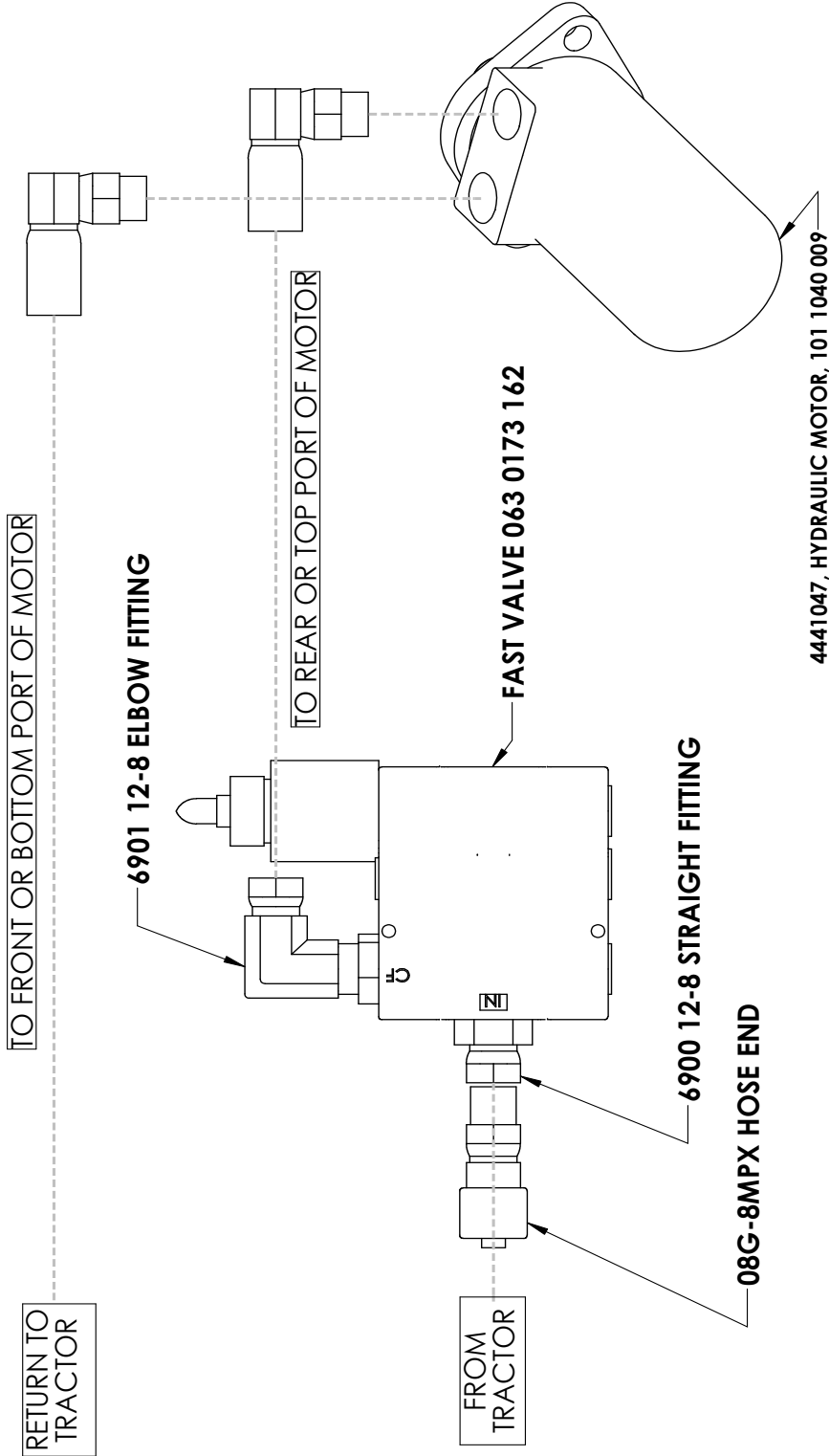

 Dalton USA A G P R O D U C T S 602 E. VAN BUREN ST., LENOX, IA 50851		DWG: VARIABLE RATE CONTROL, HYDRAULIC PLAN	
DRAWN BY: RICH SMOTHERS CHECKED BY: PRINT DATE: 4/11/2017 CONFIG: FOR DWG	4/12/2012		
COMMENTS: PROPRIETARY AND CONFIDENTIAL THE INFORMATION CONTAINED IN THIS DRAWING IS THE SOLE PROPERTY OF DALTON AG. ANY REPRODUCTION IN PART OR AS A WHOLE WITHOUT THE WRITTEN PERMISSION OF DALTON AG IS PROHIBITED.		SIZE SHEET TITLE: HYDRAULIC PLUMBING REV A	
FOR PARTS, CALL 1.800.342.7498		SCALE: 1:3	SHEET 1 OF 1

Calculate the Spreader Constant Value

The Spreader Constant value can be calculated in one of two ways: by performing a mathematical calculation, or by performing a "catch test" by applying and measuring the product used.

Note: The Spreader Constant value must be recalculated every time the gate opening dimensions are changed!

Formula Calculation:

First, use a tape measure to measure the following dimensions on the machine:

- Gate height (GH) in inches [cm]
- Gate width (GW) in inches [cm]
- Distance of travel (D) in inches [cm] of the belt per one revolution of the sensor

Second, determine the number of pulses emitted by the encoder per one revolution of the sensor.

1. Enter a METER CAL value of 10.
2. Enter a TOTAL VOL value of 0.
3. Turn the sensor exactly one revolution. The value in TOTAL VOLUME is the number of encoder pulses per sensor revolution.

Third, determine the cubic feet [cm] of discharge per one revolution of the sensor by multiplying the distance of the belt travel per one sensor revolution by the gate height by the gate width, then dividing it by 1728 (not necessary for determining cubic cm).

For Example:

Distance of Belt Travel per 1 Sensor Revolution (D) = 13 inches [33 cm]

Gate Height (GH) = 3 inches [8 cm]

Gate Width (GW) = 8 inches [38 cm]

Number of Encoder Pulses per 1 Sensor Revolution (P) = 180

$$\frac{D \times GH \times GW}{1728} = \text{Cubic Feet of Discharge per 1 Sensor Revolution}$$

$$\frac{13 \times 3 \times 8}{1728} = .181 \text{ cubic feet of discharge per 1 sensor revolution}$$

Finally, calculate the Spreader Constant value using one of the following formulas, using the example of a 180 CPR granular encoder. Write down this number for future reference when programming the console.

Rate in Pounds:

$$\frac{P}{\text{Cubic Feet of Discharge per 1 Sensor Revolution}} = \text{Spreader Constant Value}$$
$$\frac{180}{.181} = 994 \text{ Spreader Constant}$$

Calibration Numbers for Variable Rate Ready Spreaders

Inches of belt travel per revolution of rear roller = 13"

Encoder pulses per revolution of rear roller = 180

Gate Width = 8"

Gate Height = Actual inches above the floor (chain is ½" thick)

Meter Cal = Product Density

Speed Cal w/ Sky Trak = 600

Speed Cal w/Astro II = 783

Spreader Constant #'s

2" Gate Height = 1500

2.5" Gate Height = 1196

3" Gate Height = 994

3.5" Gate Height = 857

4" Gate Height = 747

4.5" Gate Height = 664

5" Gate Height = 600

*The spreader constant is entered by holding down the meter cal. button until the spreader constant menu comes available.

*These numbers are a good starting point and may be need to be adjusted slightly if your actual rate is off.

MODEL 20 ACTUATOR INSTRUCTIONS & BLEEDING

1. When installing the Model 20 Actuator, make sure the shock (#4) and slider tube (#1) are fully extended or that there is 1-1/4" movement. Bolt to mounting plate, using slots for adjustment. It is important that the blocks on the end of slider tube (#1) are tight against the blocks welded to tongue of running gear and have 1-1/4" of movement from outer diameter of pin (#2) to front of outer case (#6).
2. Fill the master cylinder with DOT 3 or 4 brake fluid. A pressure type brake bleeder may be used. If one is not available, you can bleed the system manually as follows.
3. After the master cylinder has been filled, remove the flat spring (#9) behind the emergency lever (#15). Pull forward on the lever to pump the master cylinder. Use short strokes until bubbling stops in the master cylinder.

Install bleeder hose on the bleeder valve on the first wheel with other end of the hose in a glass container partially filled with the brake fluid. Loosen the bleeder valve one turn and pump the master cylinder until the air bubbles stop coming out of the hose in the glass container, then close the bleeder valve and repeat the process with the other wheel. *Watch the fluid level in the master cylinder and refill so level does not fall below 1/2 full.*

4. After bleeding is completed, refill the master cylinder and put the filler cap on securely. Replace the flat spring behind the emergency lever.

To test the brakes, use a wrench or vise grip and clamp onto the top of the emergency lever to lengthen it. Take hold one foot above the lever pivot point and pull forward with about 100 to 150 lbs pull. Have another person try to rotate the wheels in forward rotation. You should not be able to move them. If you can, set each wheels brake adjustment up 2 to 3 notches.

5. If the emergency brake lever is applied, release the lever by pulling it forward and, with a screwdriver, lift up the front of the flat spring until it releases the lever. Many times these parts are damaged when this happens. An inspection of the lever, flat spring, and chain with S-hooks is required and any damaged parts must be replaced.

Step one: In order to replace the emergency lever, you must remove the master cylinder and the push rod. **(Be careful - Do not get dirt into the master cylinder).**

Step two: Remove the flat spring. Take the S-hook off the lever. Take the lever out from the inside.

Step three: Install the new lever from the inside and up through the slot. Replace the new flat spring. Replace the push rod, master cylinder and new gasket.

Step four: Take the new chain and fasten the S-hook to the lever by squeezing the hook shut with pliers. Check the master cylinder to make sure it is full and if needed, fill with DOT 3 or 4 brake fluid. Rebleed system following steps 2 thru 4.

MODEL 20 ACTUATOR

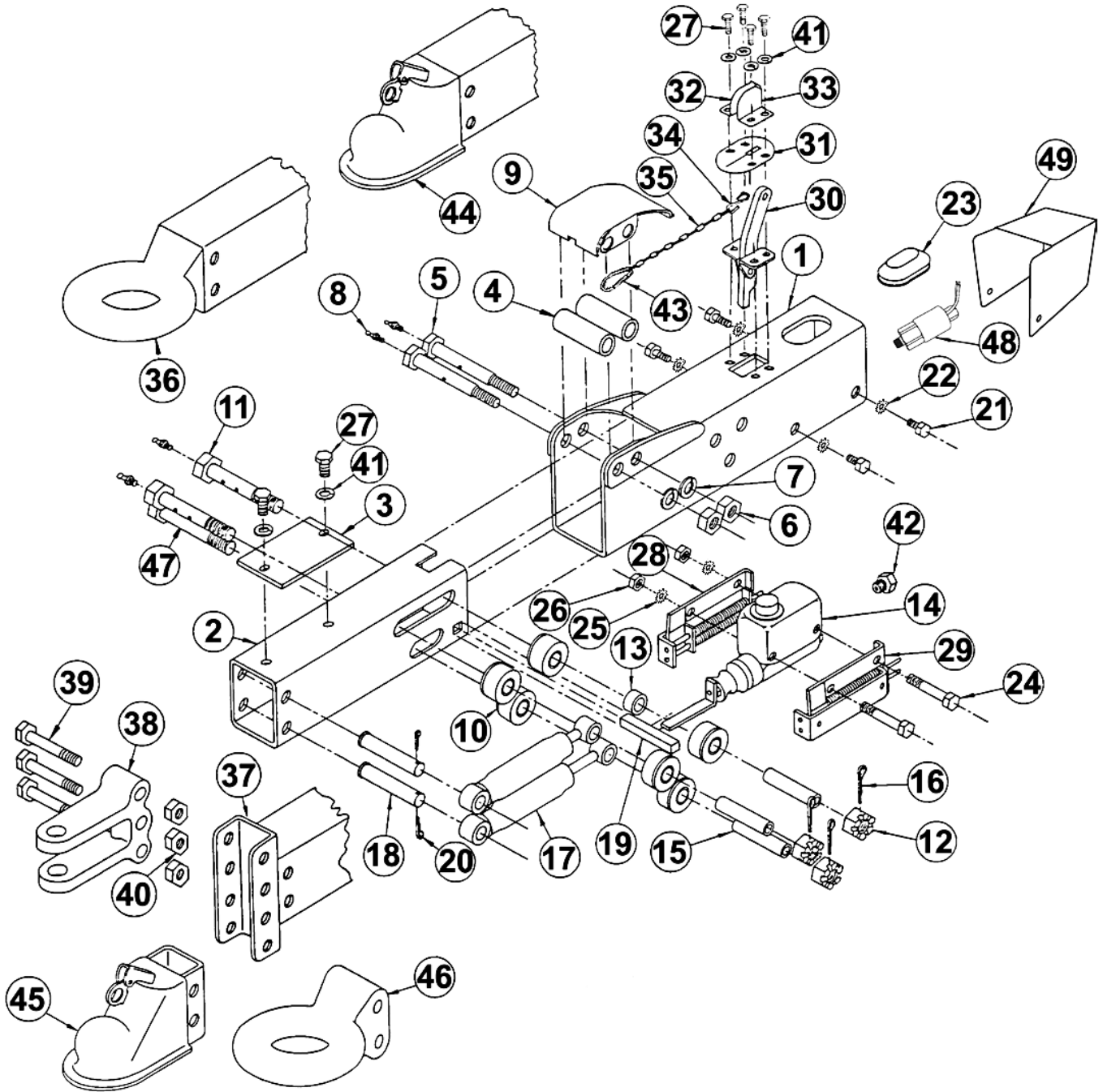

MODEL 20 ACTUATOR PARTS LIST

Model 20 Actuator Parts List

Ref No.	Part No.	Description	Quantity
1	1000000317	Outer Case, Painted, 1/4" Id Dia	1
*	1734900	Outer Case with Mounting Channel, Painted	1
*	4488000	Outer Case with Mounting Channel, Plated	1
2	1866000317	Inner Side - No Coupler, Painted	1
*	4490400317	Inner Side with 2-5/16" Drop Coupler, Painted	1
*	4490400188	Inner Side with 2-5/16" Drop Coupler, Plated	1
3	0828400	Cambering Rod	1
4	1801500	Front Roller, Plated	2
5	0828600	Front Roller Bolt, Plated	2
6	0798500	Hex Nut, 1/2" NC	2
7	0798700	Lockwasher, 1/2" Standard	2
8	0141900	Grease Felt	4
9A	0828900317	Front Roller Cover, Painted	1
9B	0828900188	Front Roller Cover, Plated	1
10	0829100	Rear Roller	6
11	0829400	Upper Rear Roller Bolt, 5/8" x 5/8" NF, Grade 5	2
12	0790100	Slotted Hex Nut, 5/8" NF	3
13	0832600	Spacer	1
	4830600	Filler Cap, Replacement for 2874400 Master Cylinder	1
14A	2874400	Master Cylinder, Drum Brake, 1-1/4" Bore	1
	4831600	Master Cylinder, Drum Brake, with 1289800 Orifice Connector	
14B	4747100	Master Cylinder, Disc Brake, 1-1/4" Bore	1
15	0829700	Spacer Sleeve	3
16	0798400	Cotter Pin 1/8" x 1-1/4"	3
17	0776400	Damper	2
18	0829600	Damper Pin	2
19	0830300	Push Rod Block	1
20	0799700	Cotter Pin 1/8" x 1"	2
21	0794600	Bolt, 5/16" x 1/2" NC, Grade 5	4
22	1346600	Star Lockwasher 5/16"	4
23	1807000	Master Cylinder Cover	1
24	0827100	Bolt, 3/4" x 3/8" NC, Grade 5	2
25	1286200	Star Lockwasher 3/8"	2
26	0797600	Hex Nut, 3/8" NC	2
27	0794800	Bolt 5/16" x 5/8" NC, Grade 5	6
28	0836600	Right Hand Cylinder Spring Bracket	1
29	0836800	Left Hand Cylinder Spring Bracket	1
30	1894100	Breakaway Lever Assembly	1
31	1895200	Weather Seal	1
32	1895700	Right Hand Breakaway Lock	1
33	1895600	Left Hand Breakaway Lock	1
34	1895500	S-Block	1
35	0776800	Safety Chain	1
36*	1297600	Inner Side, 3" Lunette Eye	1
37A	1000000317	Inner Side, 4-Hole Lever Channel, Painted	1
37B	1000000188	Inner Side, 4-Hole Lever Channel, Plated	1
38	1807800	3 Bolt Clevis Hitch	1
39	0809600	Bolt, 4-1/4" x 5/8" NC, Grade 5	1
40	1840500	Locknut, 5/8" NC	1
41	0792600	Lockwasher, 5/16" Standard	6
42	1308600	Orifice Connector, Drum Brake, 1/8" NPT	1
*	1308900	Orifice, Drum Brake, Earlier 1/2" NPT Thread Master Cylinder	1
*	0774500	Copper Gasket Used With 1308600 Orifice	1
43	4877900	Shim Wash	1
44A	1278900	Inner Side, 2-5/16" Coupler, Painted	1
44B	4498400	Inner Side, 2-5/16" Coupler, Plated	1
45A	1892000	Adjustable 2-5/16" Coupler, Painted	1
45B	4721500	Adjustable 2-5/16" Coupler, Plated	1
46A	1815700	Lunette Eye, 3" Adjustable, Uncoated	1
46B	1815700188	Lunette Eye, 3" Adjustable, Plated	1
47	0829500	Lower Rear Roller Bolt, 5/8" x 5/8" NF, Grade 5	1
48	4746600	Solenoid Valve for Disc Brakes, with Male 1/8" NPT and Female 3/8" x 24 NF with Inverted Seat for Flared Fittings	1
*	4750200	Adapter, 1/2" NF to 1/8" NPT for Solenoid Valve On Early Master Cylinder	1
49A	4896100188	Cover for Solenoid Valve, Plated	1
49B	4896100	Cover for Solenoid Valve, Painted	1
*	1816700	2874400 Master Cylinder Repair Kit	1
*	4898100	Master Cylinder Boot	1
*	4898400188	Inner Side, 6-Hole Lever Channel, Off-set	1
*	4898400188	Inner Side, 6-Hole Lever Channel, Centered	1
*	1846700	2-5/16" Coupler Repair Kit	1
*	2874600	Drum Brake Master Cylinder Assembly with Brackets	1
*	4298500042	Disc Brake Master Cylinder Assembly with Brackets	1

* = Not Shown

GATE MARKER DECAL INFO

1000529 - DECAL, GATE HEIGHT MARKER, ALL MOBILITY MODELS

To replace decal (Mobility VR Model):

Place 1/2" material on top of chain, lower gate to material, set pointer at 1"

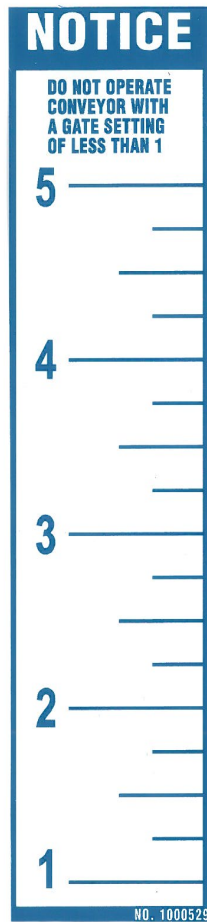

#1000529

DECAL LAYOUT

SPREADER

GROUND DRIVE



VARIABLE RATE

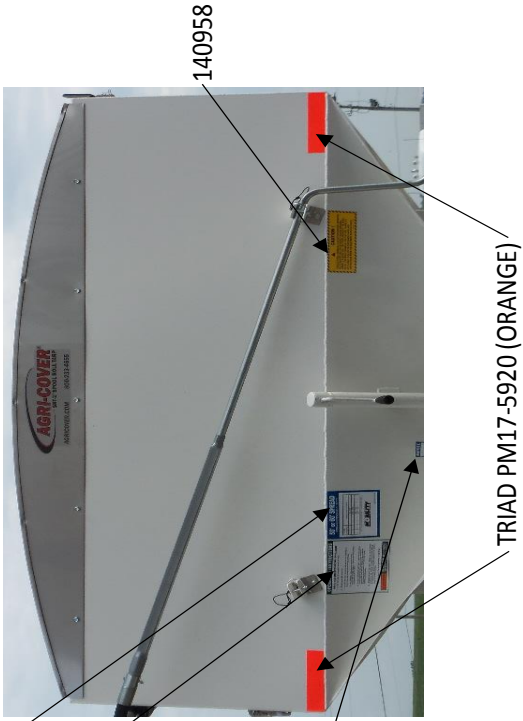

DECAL LAYOUT



TRIAD PM17-5920
 90620 BLUE
 1008495 (8TON)
 1008494 (6TON)
 1008493 (5TON)



TRIAD PM17-5910
 90620 BLUE
 1008495 (8TON)
 1008494 (6TON)
 1008493 (5TON)

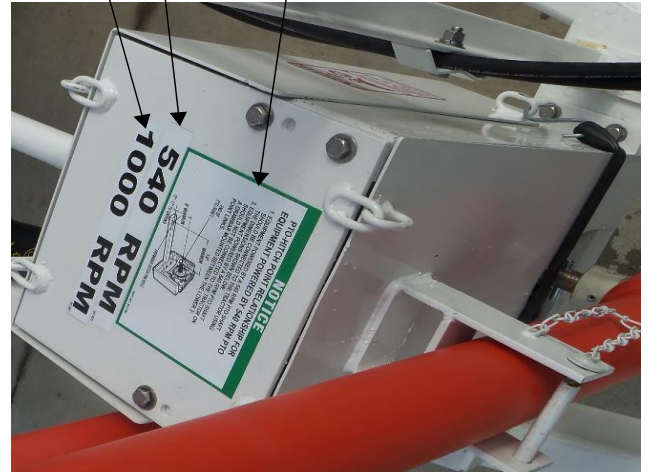

MS031 (WITH 1000/540 OPTION)
 MS030
 641702



91284

PARTS ORDERING PROCEDURE

Your Dalton Ag dealer is interested in your new fertilizer application equipment and has the desire to help you get the most value from it. Through the help of this manual, you will find you can do some of the regular maintenance yourself. For parts and service, contact the Dalton Ag Dealership from which you purchased your fertilizer application equipment or your local Dalton Ag dealer.

When replacement parts are required, consult the applicable illustration and parts list to obtain the correct part name and number. When requesting a replacement part, always include the following information:

1. Complete Part Number
2. Description
3. Quantity Required
4. Machine and Model Number
5. Machine Serial Number - located on the topside of the frame near hitch
6. Provide complete name and address for where and how parts are to be shipped.

NOTE: Right and left hand parts and sides of the units are determined by standing at the rear and facing in the direction of forward travel.

EQUIPMENT MODEL: _____

EQUIPMENT SERIAL NO.: _____

DATE OF PURCHASE: _____

NAME OF DEALER: _____

DEALER'S PHONE NUMBER: _____

Thank you for your business!

DaltonAg.com

602 E. Van Buren Lenox, Iowa 50851
100% Employee Owned

800.342.7498

NOTES

NOTES



www.daltonag.com

602 E. VAN BUREN / LENOX, IOWA 50851 / 800-342-7498