



OPERATING AND PARTS MANUAL

REACH POLE TRAILER

2019



TABLE OF CONTENTS

TO YOU THE OWNER.....	1
LIMITED WARRANTY STATEMENT.....	2
NEW MACHINE CHECKOUT.....	3
IMPLEMENT SAFETY.....	4
PRE-SEASON CHECK.....	5
BOLT TORQUE CHART.....	6
ANHYDROUS AMMONIA SAFETY.....	7
FIRST AID.....	11
ADJUSTABLE AND NON-ADJUSTABLE STANDARD AXLE REACH POLE TRAILER.....	13
4420391, REACH POLE TONGUE.....	15
4410234, EXTENDABLE TONGUE.....	16
SPRING ASSEMBLY AND FIFTH WHEEL ASSEMBLY.....	18
WN1300 REACH POLE WAGON.....	19
WN1360 REACH POLE WAGON.....	20
WA1300 REACH POLE WAGON.....	21
4410086, 888 6-BOLT HUB ASSEMBLY, COMPLETE	22
WN1600 REACH POLE WAGON.....	23
WN1660 REACH POLE WAGON.....	24
WA1600 REACH POLE WAGON	25
4410087, 6-BOLT HEAVY HUB ASSEMBLY.....	26
WN1800 REACH POLE WAGON.....	27
WN1860 REACH POLE WAGON.....	28
WA1800 REACH POLE WAGON.....	29
4410089, 813 8-BOLT HUB ASSEMBLY.....	30
PARTS ORDERING PROCEDURE.....	31

TO YOU, THE OWNER

Your Dalton Ag Equipment is the most modern, up-to-date, versatile, machine available for fertilizer application. The machine is the result of many years of experience, research, development and testing of equipment for fertilizer application. It is soundly engineered and carefully built to rigid specifications. It is of rugged and simple construction, with a minimum of moving parts.

However, to obtain maximum performance from your Dalton Ag Equipment, it is necessary to follow the instructions and safety suggestions in this manual. Each section has been carefully prepared for the purpose of providing needed and valuable information to the owner and operator. Each operator of this unit should be familiar with the contents of this manual. Keep it in a safe and convenient location. THERE ARE MANY SAFETY SUGGESTIONS (CAUTION AREAS) PRINTED THROUGHOUT THIS MANUAL. CAREFULLY READ THEM ALL BEFORE OPERATING THIS UNIT.

DESIGN IMPROVEMENTS

Dalton Ag Products follows a policy of continuous products improvement. We therefore reserve the right to make design improvements, and changes in specifications and prices, without incurring obligations to make revisions or additions to equipment previously sold.

**REGISTER
WARRANTY
ONE OF
FOUR WAYS**

- Register on-line at:
www.daltonag.com
- Fax your completed warranty registration form to:
641-333-4429
- E-mail your completed warranty registration form to:
office@daltonag.com
- Mail your completed warranty registration form to:
Dalton Ag, Inc.
P.O. Box 70
Lenox, IA 50851

LIMITED WARRANTY STATEMENT

DALTON AG, INC. warrants to the original purchaser only that all products manufactured under the Dalton Ag and Mobility Brands will be free from defects in material and workmanship under normal use and service.

DALTON AG's obligation under this warranty is limited to repairing or replacing, as it may elect, free of charge and without charge for installation, at the place of business of a dealer or distributor authorized to handle the equipment covered by this warranty or at a DALTON AG facility, any parts that prove, in DALTON AG's judgment, to be defective in material or workmanship within two (2) years after delivery to the original purchaser. DALTON AG shall not be liable for personal injuries or any special or consequential damages of any kind, either direct or indirect. This warranty is subject to acts of God, fire and existing conditions of supply and demand, production, ability or inability to deliver, or for any other valid reason beyond the reasonable control of DALTON AG. No distributor, dealer, agent or DALTON AG employee (other than DALTON's President in writing) is authorized to extend or make any other or further express or implied warranty or incur any additional obligation on DALTON AG's behalf in connection with the sale of this product.

Customer Responsibility

Product Registration - It is a condition of this warranty that the original purchaser fill out the warranty card furnished by DALTON AG and return it to DALTON AG to be recorded in DALTON AG's owner file. Registration may also be done on line at www.DaltonAg.com/warrantyregistration. If the original purchaser's card or electronic registration is not on file at DALTON AG's office, the warranty period will extend only from date equipment was picked up or shipped from the DALTON AG plant.

Maintenance - It is the customer's responsibility to maintain their equipment in accordance with the instructions provided in the Operator's Manual. DALTON AG recommends that you keep records and receipts as the customer may be required to verify the maintenance instructions have been followed.

Operation - It is the customer's responsibility to operate the equipment only for the purpose for which it was designed and in accordance with all safety and operational recommendations contained in the Operator's Manual. If a defect in materials or workmanship occurs, it is the customer's responsibility to cease operating the equipment until authorized repairs are made. Damage incurred from continued operation after a defect is discovered may not be covered by this warranty.

What this Warranty Covers

This warranty covers failures caused by defects in materials or workmanship only.

This Warranty does not cover failures caused by:

- | | | |
|------------------------------|------------------------------|---|
| - Improper operation | - Unauthorized repairs | - Usage contrary to the intended purpose of the product |
| - Natural calamities | - Use of Non DALTON AG parts | |
| - Unauthorized modifications | - Neglected maintenance | |

This Warranty does not cover replacement of Wear or Maintenance Items including, but not limited to:

- | | | | | |
|--------------|---------|----------|----------|------------|
| - Lubricants | - Hoses | - Disks | - Idlers | - Belts |
| - Filters | - Tires | - Chains | - Blades | - Bearings |

This Warranty does not cover:

- Pickup and delivery of the equipment
- Service Calls or Travel Time to and from sites
- Rental of replacement equipment during repair period
- Products that have been declared a total loss and subsequently salvaged
- Overtime labor charges

Parts Warranty

DALTON AG warrants its replacement parts against defects in materials or workmanship for a period of 90 days or the remainder of the product warranty, whichever is longer under the terms set out above. Remedy for defective replacement parts for units that are beyond the original product warranty, will be limited to replacement of the failed part.

NEW MACHINE CHECKOUT

1. All hardware properly tightened.
2. Lubrication of grease fittings.
3. Wheel bolts tightened to proper specs.

MAINTENANCE

1. Visually inspect machine daily.
2. Repair or replace any worn or damaged parts.

LUBRICATION SCHEDULE

Careful observance of the following lubrication schedule is the best preventative maintenance program for your Dalton Ag Equipment. We recommend that you establish a firm program to insure lubrication in strict compliance with the following schedule. Use only good grade pressure gun type grease unless otherwise specified.

Daily Lubrication

Hinge points

Weekly Lubrication

Wheel bearings

Annual Lubrication

Check all bearings - repack or replace as needed

IMPLEMENT SAFETY

In addition to design and configuration of equipment, safety and accident prevention are dependent upon the awareness, concern, and proper training of personnel involved in the operation, transport, maintenance, and storage of equipment. Failing to follow these safety messages can result in machine damage, personal injury, and/or death.

- Before operating your DALTON AG equipment, thoroughly read and understand your operator's manual. If you do not understand any portion of the operator's manual, contact your local Dalton Ag dealer immediately for clarification.
- Furnish this manual to a new operator.
- Tow with tractor only. Never transport equipment in excess of 20 MPH. Maintain a safe speed.
- Use a Slow-Moving-Vehicle (SMV) emblem when transporting.
- Be sure safety decals are readable. All safety related decals must be replaced if the equipment is painted or the decals are otherwise rendered unreadable.
- Install transport link before transporting.
- Always check for overhead obstacles in transporting equipment.
- Never permit riders on the equipment or tractor.
- Proceed slowly on rough or slippery roadways, on side hills, and around curves to avoid tipping.
- Reduce speed when approaching ditches and corners. Do not make sharp turns with brakes.
- Machinery should be operated only by persons familiar to the tractor, equipment, and the safety related items.
- Do not stand on, or straddle tongue when unhitching.
- Do not modify or permit anyone to modify this equipment and any of its components without first consulting your Dalton Ag dealer.
- Do not lubricate, adjust, or repair when equipment is in motion.
- Use only approved replacement parts.
- Always check torque on wheel bolts before transporting.

PRE-SEASON CHECK

1. Carefully review the safety suggestions in this manual.
2. Check all bolts for proper tightness. When the implement is new, check after one hour and every few hours of operation.
3. Check tires for proper inflation. All tires should be inflated equally to avoid side draft.
4. Check the wheel lug bolts daily, keep wheel bolts tight.
5. Grease all fittings.
6. Inspect, repack, or replace (if necessary) wheel bearings and seals.





OFF-SEASON STORAGE

Following these suggestions will extend service life and satisfaction:

1. A little time and effort spent cleaning your machine before storing will repay in longer service, easier operation and higher resale value.
2. Inspect for worn or damaged parts. Replace, if required, and avoid delays the next season.
3. Repaint all areas where the original paint is worn off.
4. Lubricate your implement.
5. Store the unit inside a shed to protect from weather and on a level area.
6. Raise tires off ground or remove and store in cool dry location out of sunlight.

IMPORTANT : Over tightening hardware can be as damaging as under tightening. Tightening beyond recommended torque will reduce the fastener's shock load capacity.

BOLT TORQUE CHART

SIZE	 SAE GRADE 2		 SAE GRADE 5		 SAE GRADE 8		 L9
	ASSEMBLY TORQUE		ASSEMBLY TORQUE		ASSEMBLY TORQUE		ASSEMBLY TORQUE
	DRY	LUBRICATED	DRY	LUBRICATED	DRY	LUBRICATED	LUBRICATED
1/4-20	66*	49*	8	75*	12	9	11
1/4-28	76*	56*	10	86*	14	10	13
5/16-18	11	8	17	13	20	18	21
5/16-24	12	9	19	14	25	20	23
3/8-16	20	15	30	23	45	30	33
3/8-24	23	17	35	25	50	35	38
7/16-14	30	24	50	35	70	55	60
7/16-20	35	25	55	40	80	60	65
1/2-13	50	35	75	55	110	80	95
1/2-20	55	40	90	65	120	90	105
9/16-12	65	50	110	80	150	110	140
9/16-18	75	55	120	90	170	130	150
5/8-11	90	70	150	110	220	170	185
5/8-18	100	80	180	130	240	180	205
3/4-10	160	120	260	200	380	280	290
3/4-16	180	140	300	220	420	320	355
7/8-9	190	140	400	300	600	460	505
7/8-14	210	155	440	320	660	500	585
1-8	220	160	580	440	900	680	775
1-14	240	170	640	480	1000	740	900
1 1/8-7	300	220	800	600	1280	960	1150
1 1/8-12	340	260	880	660	1440	1080	1325
1 1/4-7	420	320	1120	840	1820	1360	1600
1 1/4-12	460	360	1240	920	2000	1500	1750
1 3/8-6	560	420	1460	1100	2380	1780	---
1 3/8-12	640	460	1680	1260	2720	2040	---
1 1/2-6	740	560	1940	1460	3160	2360	3250
1 1/2-12	840	620	2200	1640	3560	2660	3650

**ITEMS WITH * = INCH POUNDS
ALL OTHERS = FOOT POUNDS**

WARNING: Never work around any raised implement while in the raised position without using safety lockups.

ANHYDROUS AMMONIA SAFETY

(Source: Pennsylvania State University. Agricultural Safety and Health)

Anhydrous ammonia (NH₃) is a nitrogen crop fertilizer that can cause severe chemical burns; frostbite to the eyes, skin, and respiratory tract; and death. It is important for all individuals working with this type of fertilizer to understand the potential risks, necessary safety precautions, and proper response in the event of accidental contact.

Anhydrous ammonia is a hygroscopic compound, meaning that it takes up water from the nearest source, which can include the human body—especially the eyes, lungs, and skin because of their high moisture content. Anhydrous ammonia is caustic, corrosive, and damaging to tissue high in moisture content when it contacts the human body. Anhydrous ammonia inhalation incidents are typically severe because the victim's throat can swell shut, causing suffocation. When vapors or liquid come in contact with a person's eyes, blindness may occur.

Typically, anhydrous ammonia is stored under pressure, but it vaporizes to a colorless gas. It has a unique odor that can be detected at a low concentration of 5 ppm. The concentration in fertilizer is approximately 1,000,000 ppm, but even brief exposure to a concentration of 2,500 to 6,500 ppm can result in death.

Anhydrous ammonia is transported under pressure as a liquid, so all equipment used for transport must be designed for use under high pressure to avoid ruptures or breaks. Incidents can occur when anhydrous ammonia escapes from transfer hoses or valves, equipment malfunctions and sprays anhydrous ammonia in multiple directions, hoses pull apart during transportation or application, and so on.

PPE and Supplies

It is essential that all workers who use anhydrous ammonia wear the appropriate personal protective equipment (PPE), be equipped with necessary response supplies, and know how to respond in an emergency. PPE should include ventless goggles or a full-face shield, rubber gloves with long cuffs that can be rolled to catch drips, and a long-sleeved shirt. Non-rubber gloves made of ammonia-proof material are acceptable. Because contact lenses can trap the gas and become fused to the eye, it is recommended that individuals not wear contact lenses while working with anhydrous ammonia.

In the event of an exposure emergency, the most important resource is an ample supply of clean water to begin flushing the eyes and skin. If you use a vehicle to transport anhydrous ammonia, you must carry a 5 gal. container of clean water. Each person working with anhydrous ammonia should carry a 6 to 8 fl. oz. squeeze bottle of water at all times for rapid response to an emergency.

Basic First Aid for Anhydrous Ammonia Exposure

The first-response treatment for anhydrous ammonia exposure is to flush the exposed area (skin, nose, throat, eyes, and so on) with clean water for a minimum of 15 minutes.

- Flush the exposed area immediately to decrease injury caused by the anhydrous ammonia coming in contact with skin or clothes. Although clean water is the ideal resource for flushing exposed areas of the body, if you do not have water available, other nontoxic liquids, such as cold coffee or orange juice, can be used.
- Remove contaminated clothing unless the clothing is frozen to the victim's skin.
- Seek medical attention immediately and inform medical staff of the exposure to anhydrous ammonia so that they will not treat the wounds with oils or ointments that can intensify the damage.

If you find a person who is in a continuous stream of anhydrous ammonia, contact your local emergency service responders or 911. Inform the emergency medical responders about the type of incident so they can bring the proper equipment to the scene. A self-contained breathing apparatus (SCBA) and protective clothing are necessary to remove a person from a continuous stream. Rescue workers will contact a hazardous materials (HAZMAT) disposal team if HAZMAT services are needed at the scene.

Note that these guidelines are not comprehensive, and all individuals working with anhydrous ammonia should receive training in the proper response to exposure emergencies.

Storage and Transportation

Anhydrous ammonia is a strong alkali that, when dissolved in water, readily reacts with copper, zinc, brass, and other alloys. Therefore, the only types of containers, fittings, and piping that should come in contact with anhydrous ammonia should be non-galvanized steel or iron. Do not store other materials, such as propane or liquefied petroleum gas, in a tank that has been used to store anhydrous ammonia.

When filling your anhydrous ammonia tank, do not fill it more than 85% full, and always disconnect the fill hose before moving the tank. Remember to bleed pressurized anhydrous ammonia from the hose before connecting or disconnecting the hose.

When transporting anhydrous ammonia, be sure to adhere to the following precautions and safety rules:

- **Running Gear:** Regularly inspect the wagon's frame tongue, reach poles, anchor devices, wheel bearings, knuckles, ball joints, and pins for structural damage and wear and make necessary repairs and adjustments.
- **Tires:** Check tires for proper inflation, bald spots, and signs of wear and ensure that lug nuts are tight.
- **Hoses and Valves:** Inspect and replace hoses and valves as needed.
 - o The hydrostatic relief valve should be replaced every five years.
 - o The transfer hose should be replaced five years from the date of manufacture.

- **Lubrication:** Annually lubricate the wagon's knuckle, wheels, tongues, and so on.
- **Towing Vehicle:** To increase the driver's ability to control the towing vehicle, ensure that the towing vehicle weighs at least as much as the tank.
 - o A tractor can tow two tanks, but a truck can tow only one tank at a time.
- **Speed Limit:** When towing an anhydrous ammonia tank, observe a speed limit of 25 mph.
- **Hitch Pin:** Use a hitch pin with a safety chain when towing a tank wagon.
- **Warning Lights:** Ensure that the tank is equipped with a seven-terminal breakaway connector plug to properly operate turn signals, flashing warning lights, and a red brake light.
- **Safety Signage:** If operating on a highway, outfit the tank with all required safety markings, including a slow-moving vehicle (SMV) sign.
 - o The words *Anhydrous Ammonia* must appear on both sides of the tank and on the rear of the tank in letters 4 in. high. The words should be in contrast to the tank so that they can be read easily.
 - o *Inhalation Hazard* must appear on both sides of the tank in letters 3 in. high.
 - o A Department of Transportation (DOT) placard number 1005 for nonflammable gas should be placed on the front, back, and sides of the tank.

Additional Safety Recommendations

- Paint the tank with reflective white paint to decrease excessive pressure buildup that can occur when the tank is heated from direct sunlight.
- Do not use dented or damaged tanks until they have been checked by an authorized inspector and necessary repairs are completed.
- Allow only certified welders to perform welding on the tank.
- Regulations and codes regarding towing of anhydrous ammonia and signage may vary, so be familiar with and obey the regulations in your state.

Summarized by:

Linda M. Fetzer, Pennsylvania State University – lmf8@psu.edu

Reviews:

LaMar Grafft, University of Iowa – lamar-grafft@uiowa.edu

Dennis J. Murphy, Pennsylvania State University – djm13@psu.edu

J. Samuel Steel, Pennsylvania State University – jss13@psu.edu

Aaron M. Yoder, University of Nebraska Medical Center - aaron.yoder@unmc.edu

Use the following format to cite this article:

Anhydrous ammonia safety. (2012) Farm and Ranch eXtension in Safety and Health (FReSH) Community of Practice. Retrieved from <http://www.extension.org/pages/63196/anhydrous-ammonia-safety>.

Sources

Schwab, C., Hanna, M., & Miller, L. (2008) Anhydrous ammonia safety: Play it safe with anhydrous ammonia. Iowa State University Extension and Outreach. Retrieved from <https://store.extension.iastate.edu/ItemDetail.aspx?ProductID=4989>.

Training module: Safe handling of anhydrous ammonia (NH₃). (2002) Ohio State University Extension. Retrieved from <http://nasdonline.org/1731/d001719/safe-handling-of-anhydrous-ammonia-nh....>

Training module: Towing anhydrous ammonia tanks. (2002) Ohio State University Extension Agricultural Tailgate Safety Training. Retrieved from <http://nasdonline.org/1794/d001750/towing-anhydrous-ammonia-tanks.html>

FIRST AID

Decontaminate the victim as quickly as possible. Start with the eyes. The whole body, or exposed area, must be flushed with generous amounts of water; this includes the hair, ears, under the chin, and armpits. Water sources such as showers, hoses, eye wash stations, or stock tanks are acceptable [29 CFR 1910.151(c)]

Ensure trained personnel and adequate first aid supplies are readily available [29 CFR 1910.151(b)]



Eyewash Station

Contact with the Eyes

Even if only a small amount of ammonia enters the eyes, irrigate the eyes with an abundance of water for a minimum of 15 minutes. Continually and thoroughly flush the entire eye surface and the inner lining of the eyelids. Eyes affected by ammonia close involuntarily, so the eyelids must be held open so that water can flush the entire eye surface, as well as the inner lining of the eyelid.

If there is no physician available, continue irrigation for an additional 15 minutes.

Do not wear contact lenses when handling anhydrous ammonia. If ammonia gets in the eyes, the ammonia will get trapped under the lenses causing even more damage. They may also prevent immediate flushing of the eye surface.

Serious eye injury should be treated by an ophthalmologist, but in an emergency, wash with large quantities of water for 15 minutes or more as quickly as possible. In fact, the only real hope for preventing permanent eye injury lies in quick and generous washing.

One suggestion for those likely to be exposed is to carry a small, eight-ounce squeezable squirt bottle filled with water, which can be used to get excess ammonia out of the eyes until a larger water supply can be reached. This small amount of water is not sufficient to remove all the ammonia. It is essential that the eyes be irrigated for a minimum of 15 minutes as soon as possible.



Squirt Bottle

Another emergency method is to duck the head in water and rapidly blink and move or rotate the eyes about.

Contact with the Skin

It is essential that any ammonia spilled on the worker be removed immediately and that the worker be moved to an uncontaminated area quickly.

Clothes that have been saturated by liquid ammonia may freeze to the skin. In any case, the victim, still clothed, should get immediately under a shower, if available, or jump into a stock tank, pond, or into any other source of water. Time is important! Remove clothes only after they are thawed and they can be freely removed from frozen areas. If the clothing is removed incorrectly, whole sections of skin can be torn off.

No salves, creams, ointments, or jellies should be applied to the skin during a 24-hour period following the injury since this will prevent natural elimination of the ammonia from the skin. After the 24 hour period, the medical treatment is the same for thermal burns. A physician should view any second- or third-degree freeze burns of the skin.

Taken Internally: This is what you should do if ammonia is ingested:

- Call a physician.
- If conscious, have the victim drink large amounts of water.
- Do not induce vomiting if the victim is in shock, in extreme pain, or is unconscious.
- If vomiting begins, place the victims face down with head lower than hips. This prevents vomit from entering the lungs and prevents severe injury.

Inhalation

In all inhalation exposures, severe or minimal:

- Take the exposed workers at once to a clean, uncontaminated area.
- Watch workers exposed to low concentrations for a short period of time. They will usually require no treatment and can be released.
- For severe exposure to higher concentrations:

Call a physician.

Administer oxygen by an individual who is trained and authorized to do so by a physician. This will help relieve pain and symptoms of lack of oxygen.

Begin artificial respiration immediately if the patient is not breathing.

Keep victim warm (but not hot) and rested until transported to the hospital.

Summary: In any accident involving contact with ammonia with the eyes or skin:

- Immediately flush the affected area with large quantities of clean water.
- Place the injured person into a container of clean water or under an emergency shower.
- Provide the injured worker with first aid treatment and call a physician at once in the case of extreme exposure. Give the physician a complete account of the incident.
- Seconds count, wash the ammonia away with water immediately.

Information from U.S. Department of Labor - OSHA

https://www.osha.gov/SLTC/etools/ammonia_refrigeration/emergency/index.html#firstaid

ADJUSTABLE AND NON-ADJUSTABLE STANDARD AXLE REACH POLE TRAILER

ASSEMBLY: Recommended Procedures for Standard Axle Adjustable and Non-Adjustable

The only difference between these two trailers is the adjustable axle. Assembly for both is the same.

Assembly will be easier if the sub-assembly sections of the trailers are laid out in the manner and order in which they will be put together.

Starting by placing front and rear axles on sturdy saw horses. Lay the tongue assembly in front of the axle, and place the reach pole off to the side, but laid lengthwise. Place the fifth wheel assembly on the floor behind the front axle.

FIFTH WHEEL ASSEMBLY - Both Trailers

Refer to drawing, page 4 & 6, for parts location and placement.

1. Remove fifth wheel king pin (621037) from fifth wheel assembly.
2. Allow fifth wheel brace (621068) to swing back, out of the way. If necessary, loosen its retaining nut and bolt.
3. Place fifth wheel assembly of fifth wheel plate on the front axle.
4. Swing fifth wheel brace into position. The top side of this brace fits flush against the bottom side of the front axle.
5. Insert king pin, making sure it passes through the upper and lower fifth wheel plates, the axle, and through the hole in the brace. Secure king pin with nut and bolt provided.
6. Tighten fifth wheel brace retaining nut and bolt if it was loosened for fifth wheel assembly.

REACH POLE ASSEMBLY - Both Trailers

NOTE: Notice that each end of the reach pole contains two sets of holes. The spacing of these holes is different in each end of the reach pole. One set of holes will match holes on the sleeve of the fifth wheel assembly. By measuring, or holding the reach pole next to the fifth wheel assembly reach pole sleeve, be sure you have the correct end of the reach pole facing the fifth wheel sleeve.

1. Insert the reach pole in the fifth wheel assembly reach pole sleeve.
2. Align the mounting holes in the reach pole with the holes in the sleeve. Secure with two nuts and bolts provided.
3. To attach reach pole to the rear bolster, position the reach pole collar to allow reach pole to slide into position.
4. Align bolt holes and secure with bolts and nuts provided in a separate bag or container.

REAR BLOCK RISER/SPRING ASSEMBLY - Both Trailers

1. Depending on your choice of options, mount and attach either rear block risers, or rear spring assemblies.

NOTE: It is a good idea, when mounting the risers or springs, to leave these assemblies loose enough so that they can be moved by hand. Also, it is a good idea at this point, to loosen the front spring assemblies so that they may be easily moved by hand. This will make tank mounting, seating, and securing easier. Once the tank is mounted, tighten springs and riser assemblies.

ADJUSTING AXLE - Adjustable Axle

1. Loosen U-Bolt (641561)* on both sides of front axle.
2. Move both sliding axles outward, precisely the same amount on each side, to desired axle width.
3. Tighten U-Bolt nuts on both sides of front axle.
4. Repeat steps 1 through 3 above for rear axle adjustment.

TONGUE ASSEMBLY - Both Trailers

1. Remove nuts, washers, and bolts from tongue assembly.
2. Attach tongue to front bolster tongue attach points with hardware just removed.
3. Attach safety chains, mount wheels, and remove your completed trailer from blocks or saw horses.

OPERATIONS - Recommendations For Better Operating Performance

To get the most out of your Dalton Ag running gear. Perform the following steps on a regular basis.

1. Inspect nuts, bolts and connections, especially moving parts, or points of stress. Look for unusual wear and correct the problem.
2. Inspect springs or risers and tank mounting hardware. Look for bolt stress, loose nuts, and unusual wear.
3. The following is the manufacturer's recommended tire pressure at 20 MPH.

TIRE SIZE	MAX. LOAD	PRESSURE
11 L X 15 6-PLY	2150 LBS.	24 PSI
11 L X 15 8-PLY	2550 LBS.	32 PSI
12.5 L X 15 8-PLY	2010 LBS.	32 PSI

4. Check wheel bearings for wear and proper lubrication. Repack at least once per year.
5. Lubricate tongue attach points at two zerks on tongue assembly.
6. Lubricate fifth wheel plates at zerks located on upper fifth wheel plate.
7. Inspect fifth wheel king pin.

4420391 REACH POLE TONGUE

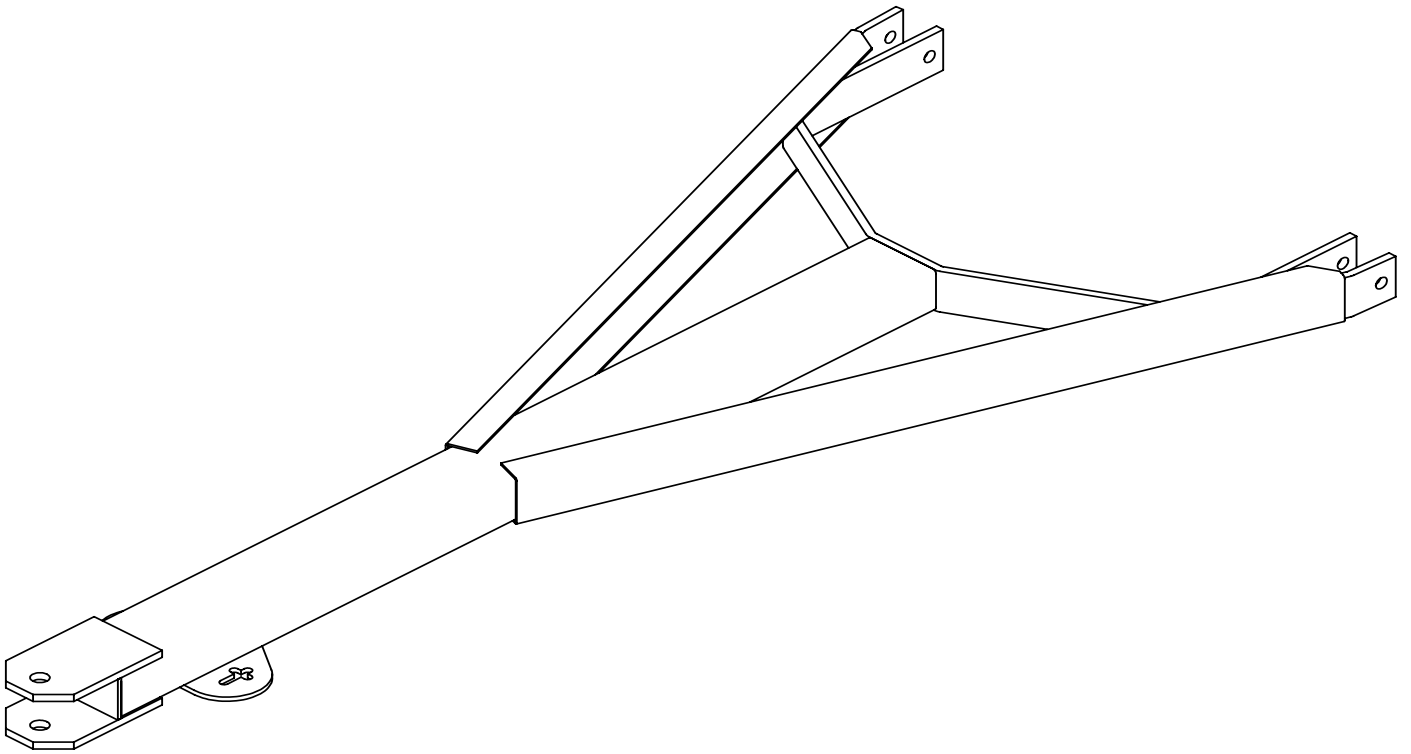

RP 4420391 TONGUE

Available:
610500-SAFETY CHAIN, PAIR

DRAWN BY	RICH SMOTHERS	8/11/2010
CHECKED BY		
PRINT DATE	4/28/2015	
CONFIG.	Default	
COMMENTS:		



PROPRIETARY AND CONFIDENTIAL
THE INFORMATION CONTAINED IN THIS DRAWING IS THE SOLE PROPERTY OF DALTON AG. ANY REPRODUCTION IN PART OR AS A WHOLE WITHOUT THE WRITTEN PERMISSION OF DALTON AG IS PROHIBITED.

DWG: REACH POLE TONGUE

SIZE	SHEET TITLE:	REV
A	Sheet1	A

FOR PARTS, CALL 1.800.342.7498

SCALE: 1:10

SHEET 1 OF 1

4410234 EXTENDABLE TONGUE

ADJUSTABLE TONGUE

4410234 ADJUSTABLE TONGUE

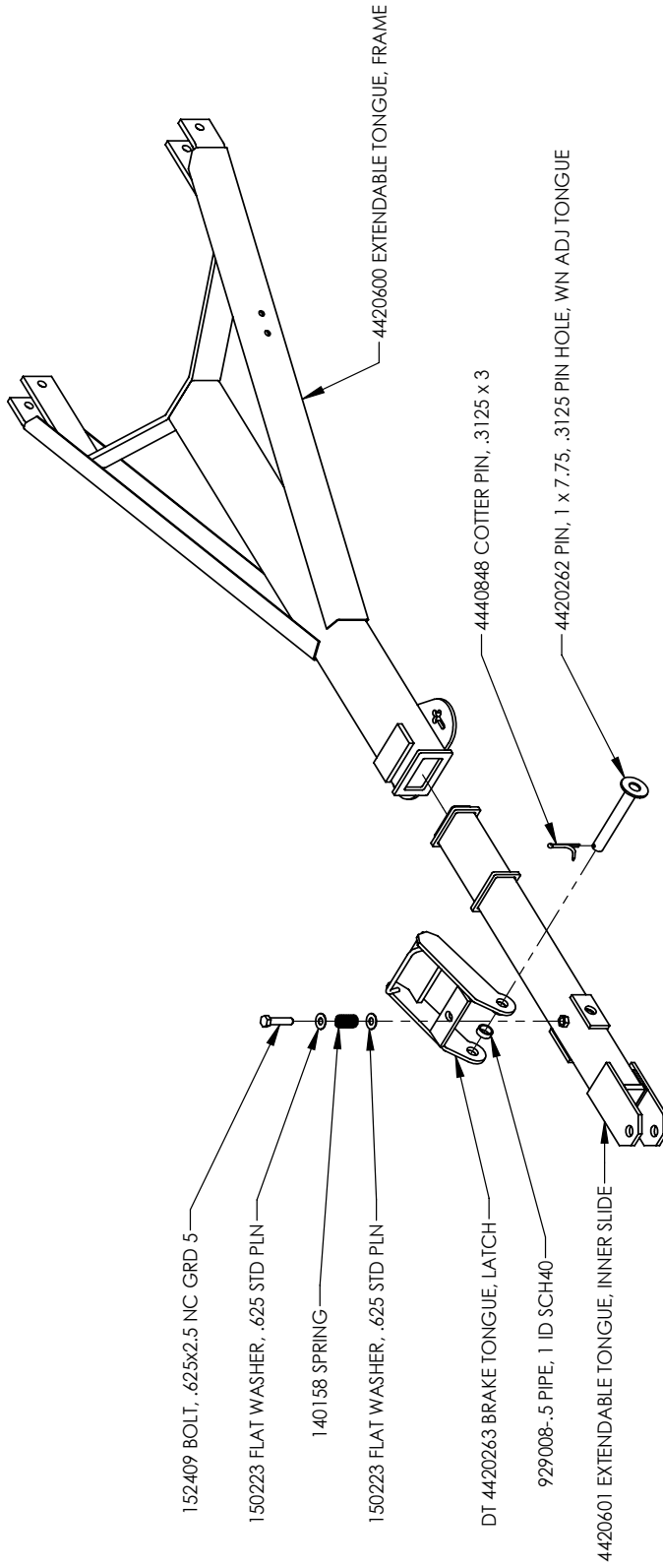

Available:
610500-SAFETY CHAIN, PAIR

DRAWN BY	RICH SMOTHERS	1/27/2014
CHECKED BY		
PRINT DATE	4/18/2016	
CONFIG.	EXPLODED VIEW	
COMMENTS:		



DWG: ADJUSTABLE TONGUE

SIZE	A	SHEET TITLE:	Sheet1	REV	A
------	---	--------------	--------	-----	---

SCALE: 1:15 SHEET 1 OF 1

PROPRIETARY AND CONFIDENTIAL
THE INFORMATION CONTAINED IN THIS DRAWING IS THE SOLE PROPERTY OF DALTON AG. ANY REPRODUCTION IN PART OR AS A WHOLE WITHOUT THE WRITTEN PERMISSION OF DALTON AG IS PROHIBITED.

FOR PARTS, CALL 1.800.342.7498

5

4

3

2

1

COMING SOON:
LIFT ASSIST FOR TONGUE

SPRING ASSEMBLY AND FIFTH WHEEL ASSEMBLY

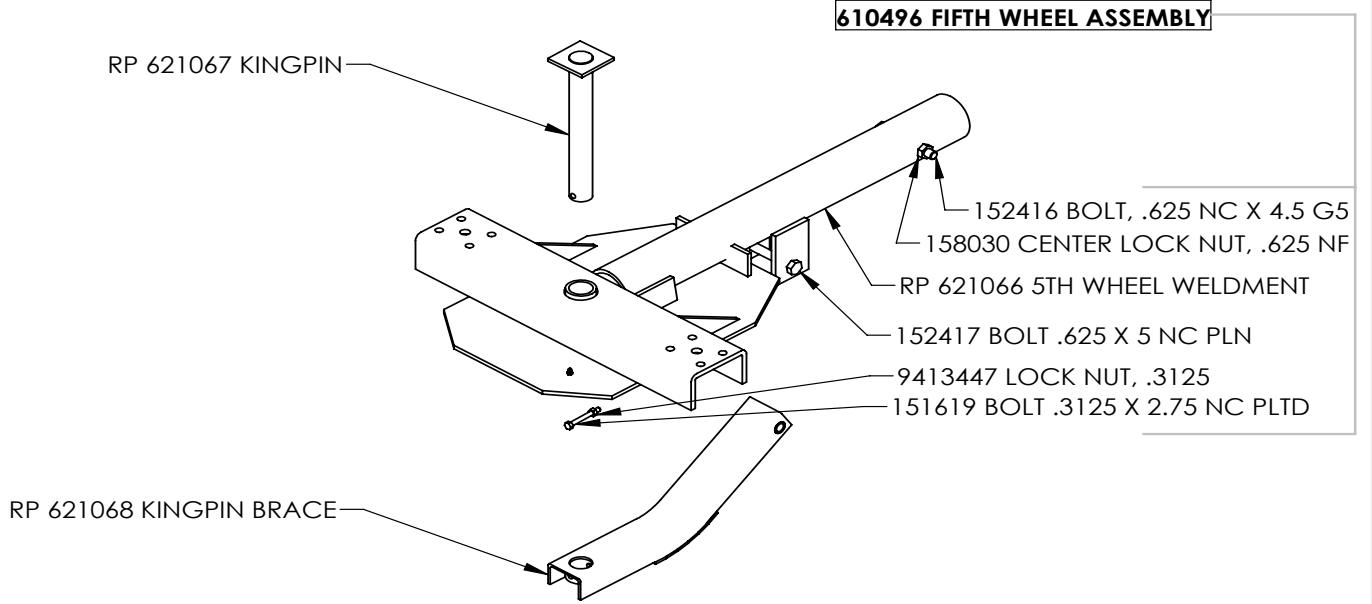
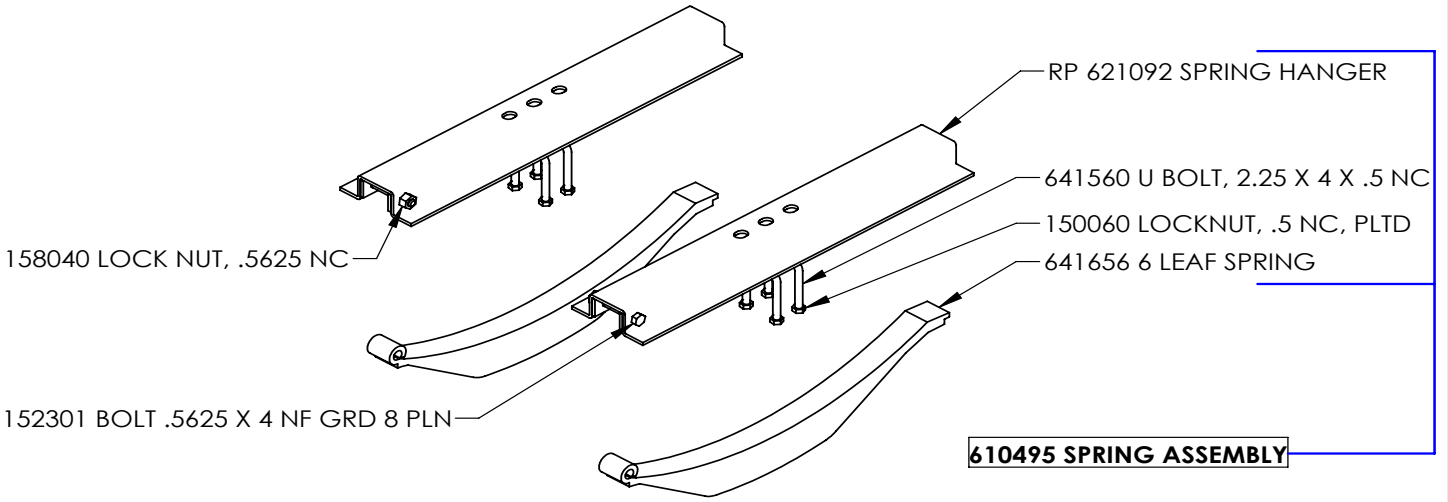

DRAWN BY	RICH SMOTHERS	9/5/2014
CHECKED BY		
PRINT DATE	11/16/2015	
CONFIG.	Default	
COMMENTS:		



PROPRIETARY AND CONFIDENTIAL
 THE INFORMATION CONTAINED IN THIS DRAWING IS THE SOLE PROPERTY OF DALTON AG. ANY REPRODUCTION IN PART OR AS A WHOLE WITHOUT THE WRITTEN PERMISSION OF DALTON AG IS PROHIBITED.

DWG: REACH POLE COMMON COMPONENTS

SIZE A	SHEET TITLE: Sheet1	REV A
SCALE: 1:12		SHEET 1 OF 1

FOR PARTS, CALL 1.800.342.7498

WN1300 REACH POLE WAGON

WN1300 REACH POLE WAGON

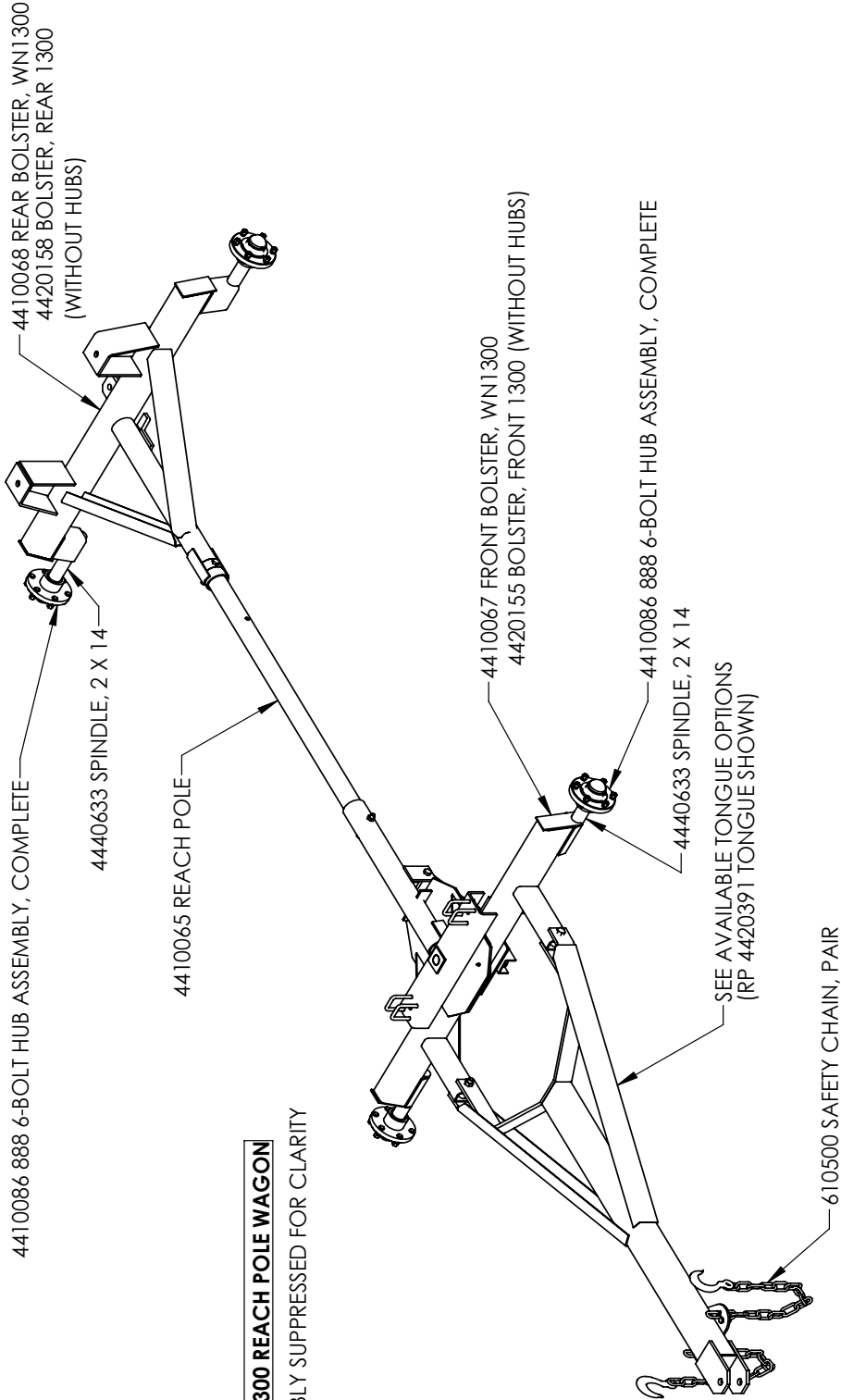

DRAWN BY	RICH SMOTHERS	9/5/2014	 602 E. VAN BUREN ST., LENOX, IA 50851	
CHECKED BY				
PRINT DATE	5/12/2015		DWG:	WN1300 REACH POLE WAGON
CONFIG.	Default		SIZE	A
COMMENTS:			SHEET TITLE:	Sheet1
			REV	A
<p>PROPRIETARY AND CONFIDENTIAL THE INFORMATION CONTAINED IN THIS DRAWING IS THE SOLE PROPERTY OF DALTON A.G. ANY REPRODUCTION IN PART OR AS A WHOLE WITHOUT THE WRITTEN PERMISSION OF DALTON A.G. IS PROHIBITED.</p>			SCALE:	1:24
<p>FOR PARTS, CALL 1.800.342.7498</p>			SHEET 1 OF 1	

WN1360 REACH POLE WAGON

WN1360 REACH POLE WAGON

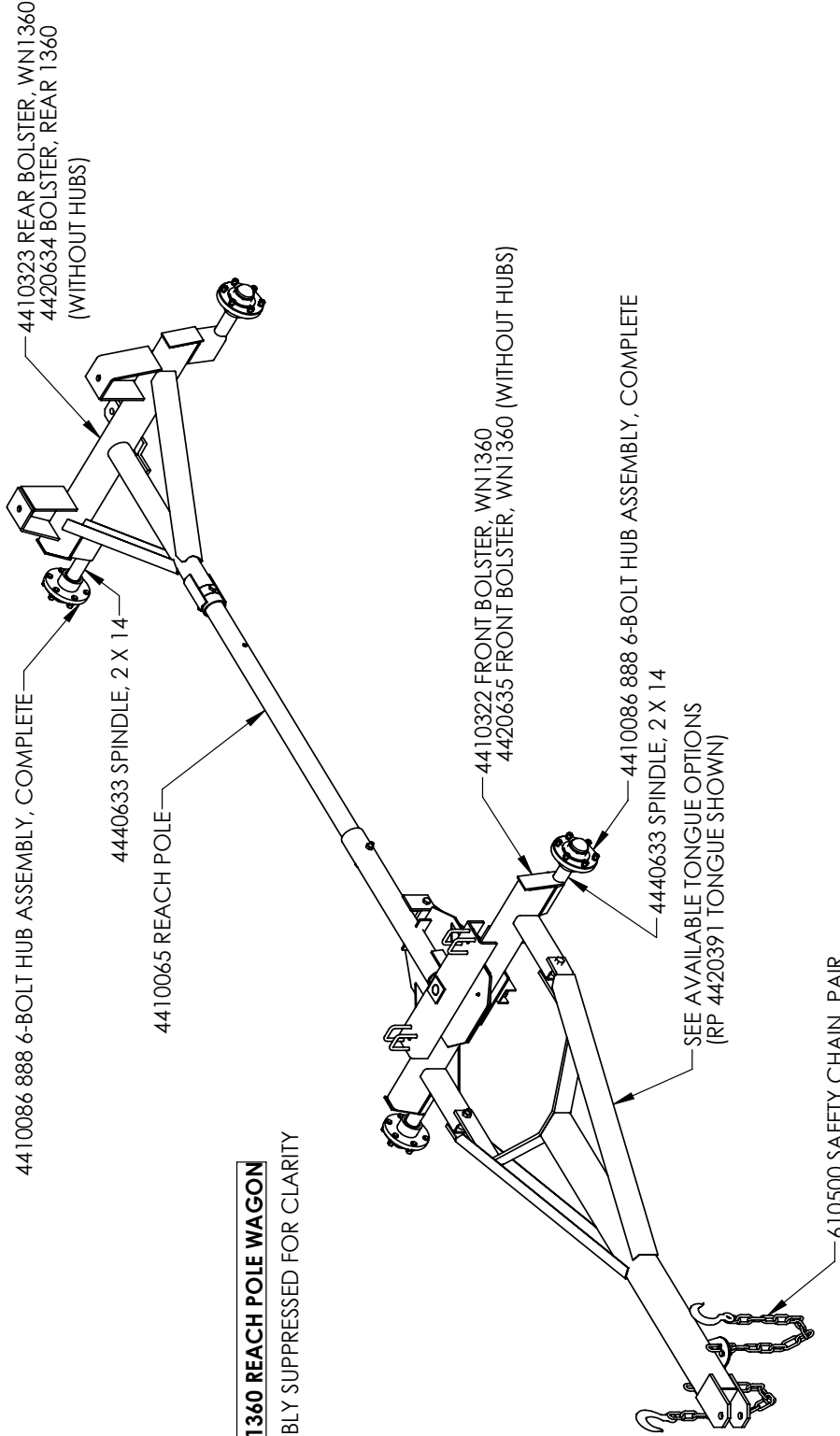

4400072 WN1360 REACH POLE WAGON

SPRING ASSEMBLY SUPPRESSED FOR CLARITY

DRAWN BY	RICH SMOTHERS	9/5/2014	 <p>602 E. VAN BUREN ST., LENOX, IA 50851</p>	
CHECKED BY				
PRINT DATE	5/11/2015		DWG:	WN1360 REACH POLE WAGON
CONFIG.	Default		SIZE	A
COMMENTS:			SHEET TITLE:	Sheet1
			REV	A
<p>PROPRIETARY AND CONFIDENTIAL THE INFORMATION CONTAINED IN THIS DRAWING IS THE SOLE PROPERTY OF DALTON A.G. ANY REPRODUCTION IN PART OR AS A WHOLE WITHOUT THE WRITTEN PERMISSION OF DALTON A.G. IS PROHIBITED.</p>			SCALE:	1:24
<p>FOR PARTS, CALL 1.800.342.7498</p>			SHEET 1 OF 1	

WA1300 REACH POLE WAGON

WA1300 REACH POLE WAGON

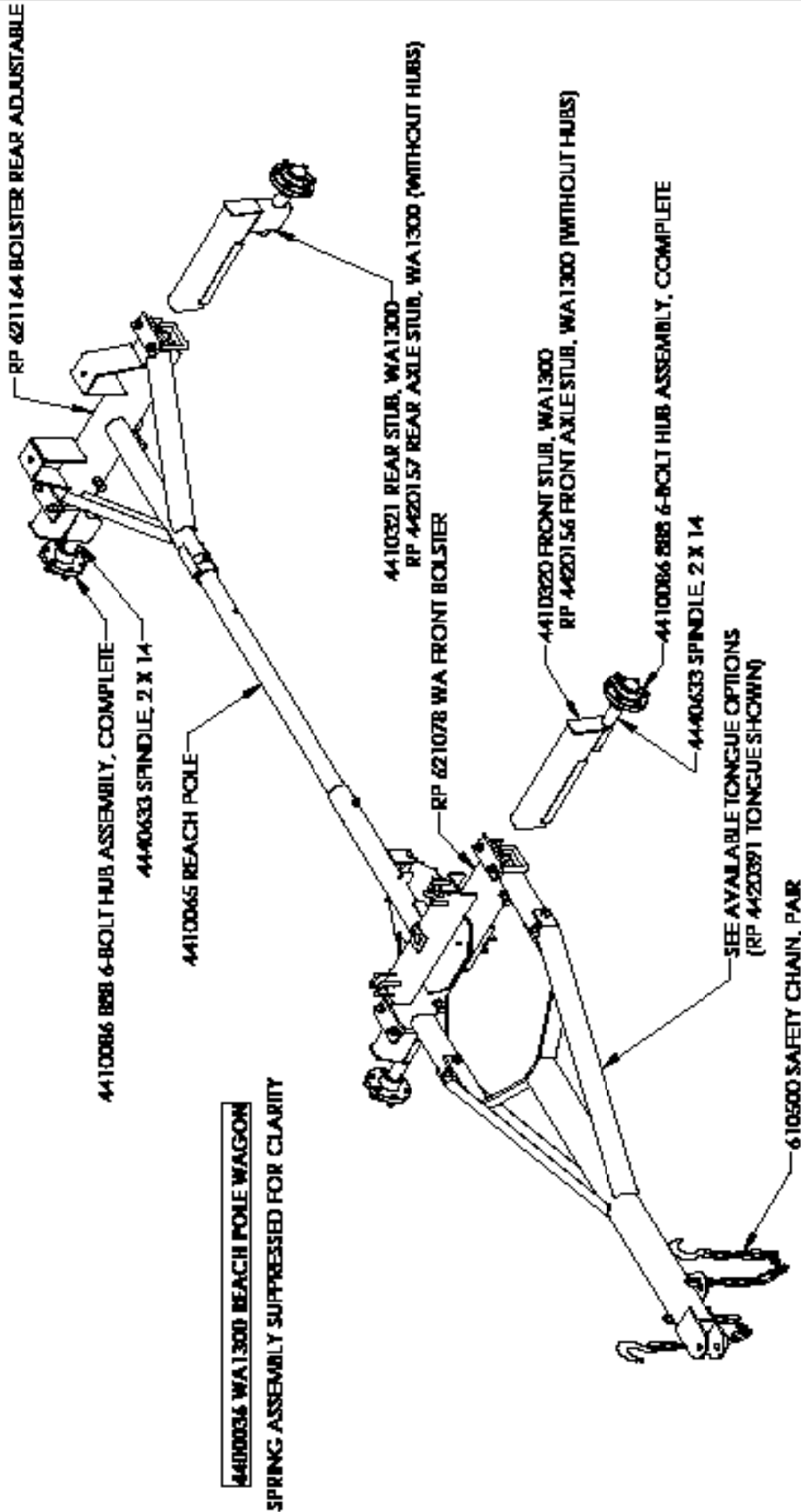

DRAWN BY RICH SMOTHERS	9/8/2014		DMG: WA1300 BEACH POLE WAGON
CHECKED BY			
PERM DATE	5/11/2015		
CONFIG. Default			
COMMENTS:			
PROPRIETARY AND CONFIDENTIAL THE INFORMATION CONTAINED IN THIS DRAWING IS THE SOLE PROPERTY OF DALTON AND ANY REPRODUCTION IN PART OR AS A WHOLE WITHOUT THE WRITTEN PERMISSON OF DALTON IS FORBIDDEN.			
FOR PARTS, CALL 1.800.342.7478		SCALE: 1:24	SHEET 1 OF 1
5	4	3	2
			1

4410086, 888 6-BOLT HUB ASSEMBLY, COMPLETE

ASSEMBLY

4410086 888 6-BOLT HUB ASSEMBLY, COMPLETE

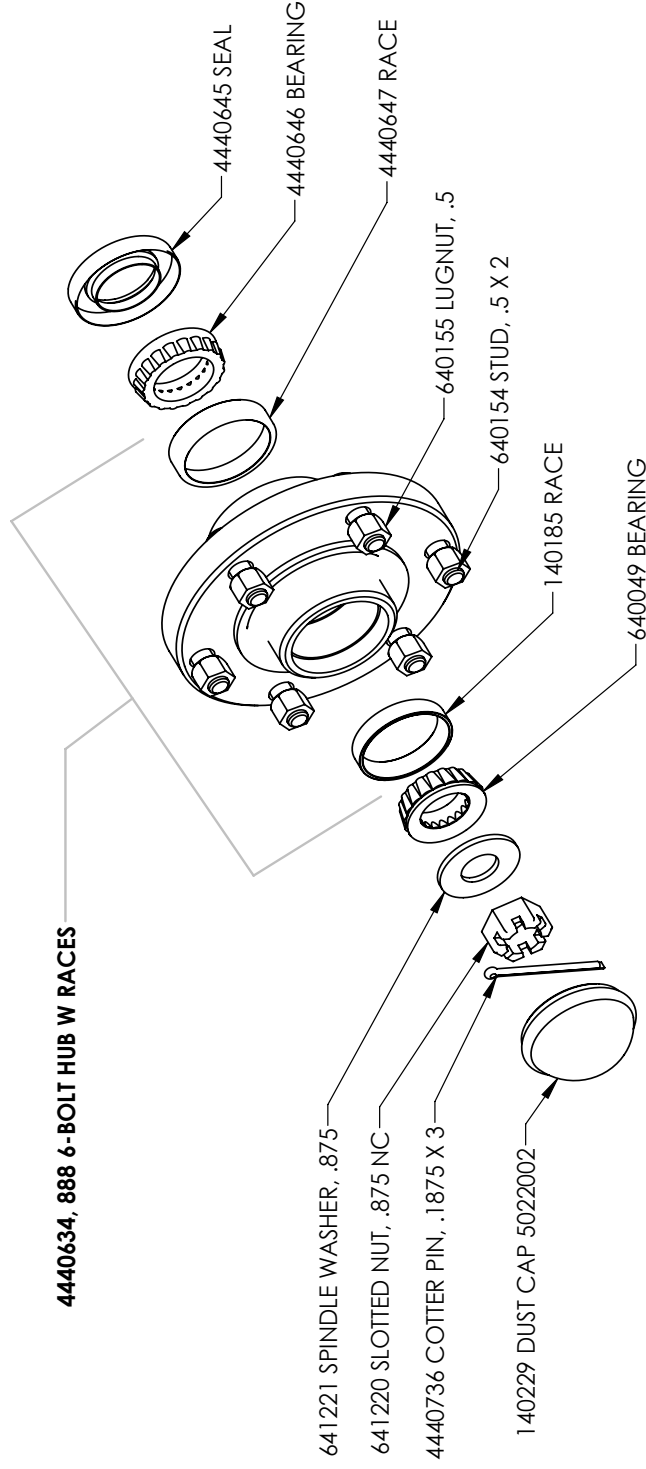

4410086 888 6-BOLT HUB ASSEMBLY, COMPLETE

DRAWN BY	RICH SMOTHERS	5/4/2009		
CHECKED BY				
PRINT DATE	12/13/2017			
CONFIG.	EXPLODED			
COMMENTS:	<p>PROPRIETARY AND CONFIDENTIAL THE INFORMATION CONTAINED IN THIS DRAWING IS THE SOLE PROPERTY OF DALTON AG. ANY REPRODUCTION IN PART OR AS A WHOLE WITHOUT THE WRITTEN PERMISSION OF DALTON AG IS PROHIBITED.</p>			
DWG:	4410086 888 6-BOLT HUB ASSEMBLY, COMPLETE			
SIZE	A	SHEET TITLE:	Sheet1	REV
SCALE:	1:4	SHEET 1 OF 1		A

WN1600 REACH POLE WAGON

WN1600 REACH POLE WAGON

4400116 WN1600 REACH POLE WAGON, DOUBLE

610499-1 REACH POLE

610494 REAR BOLSTER, WN1600
RP 621064 WN REAR BOLSTER
SOLID 1600 (WITHOUT HUBS)

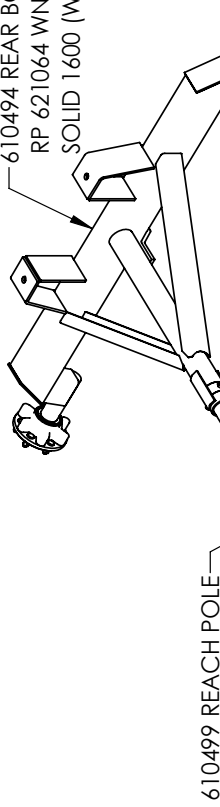

600652 WN1600 REACH POLE WAGON

SPRING ASSEMBLY SUPPRESSED FOR CLARITY

140350-13 SPINDLE, 13 INCH
4410087 6 BOLT HEAVY, HUB ASSEMBLY, COMPLETE
610493 FRONT BOLSTER, WN1600
RP 621063 WN FRONT BOLSTER SOLID 1600 (WITHOUT HUBS)

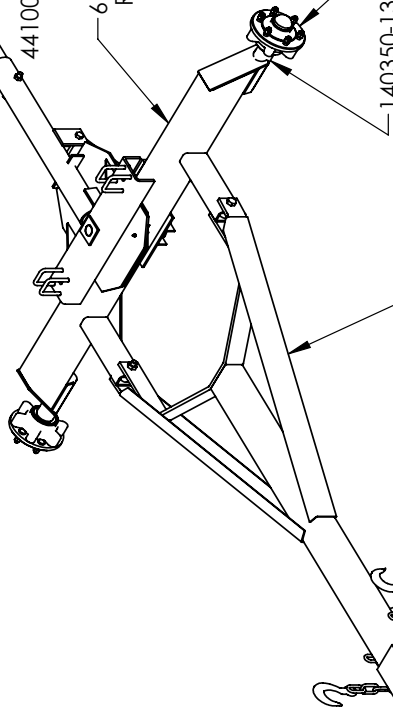

SEE AVAILABLE TONGUE OPTIONS
(RP 4420391 TONGUE SHOWN)

610500 SAFETY CHAIN, PAIR

DRAWN BY RICH SMOTHERS 9/5/2014

CHECKED BY

PRINT DATE 5/12/2015

CONFIG. Default

COMMENTS:

PROPRIETARY AND CONFIDENTIAL
THE INFORMATION CONTAINED IN THIS
DRAWING IS THE SOLE PROPERTY OF
DALTON A.G. ANY REPRODUCTION IN
PART OR AS A WHOLE WITHOUT THE
WRITTEN PERMISSION OF DALTON A.G. IS
PROHIBITED.



DWG: WN1600 REACH POLE WAGON

SIZE **A** SHEET TITLE: Sheet1 REV **A**

SCALE: 1:24 SHEET 1 OF 1

FOR PARTS, CALL 1.800.342.7498

5

4

3

2

1

WN1660 REACH POLE WAGON

WN1660 REACH POLE WAGON

4400115 WN1660 REACH POLE WAGON, DOUBLE

610499-1 REACH POLE

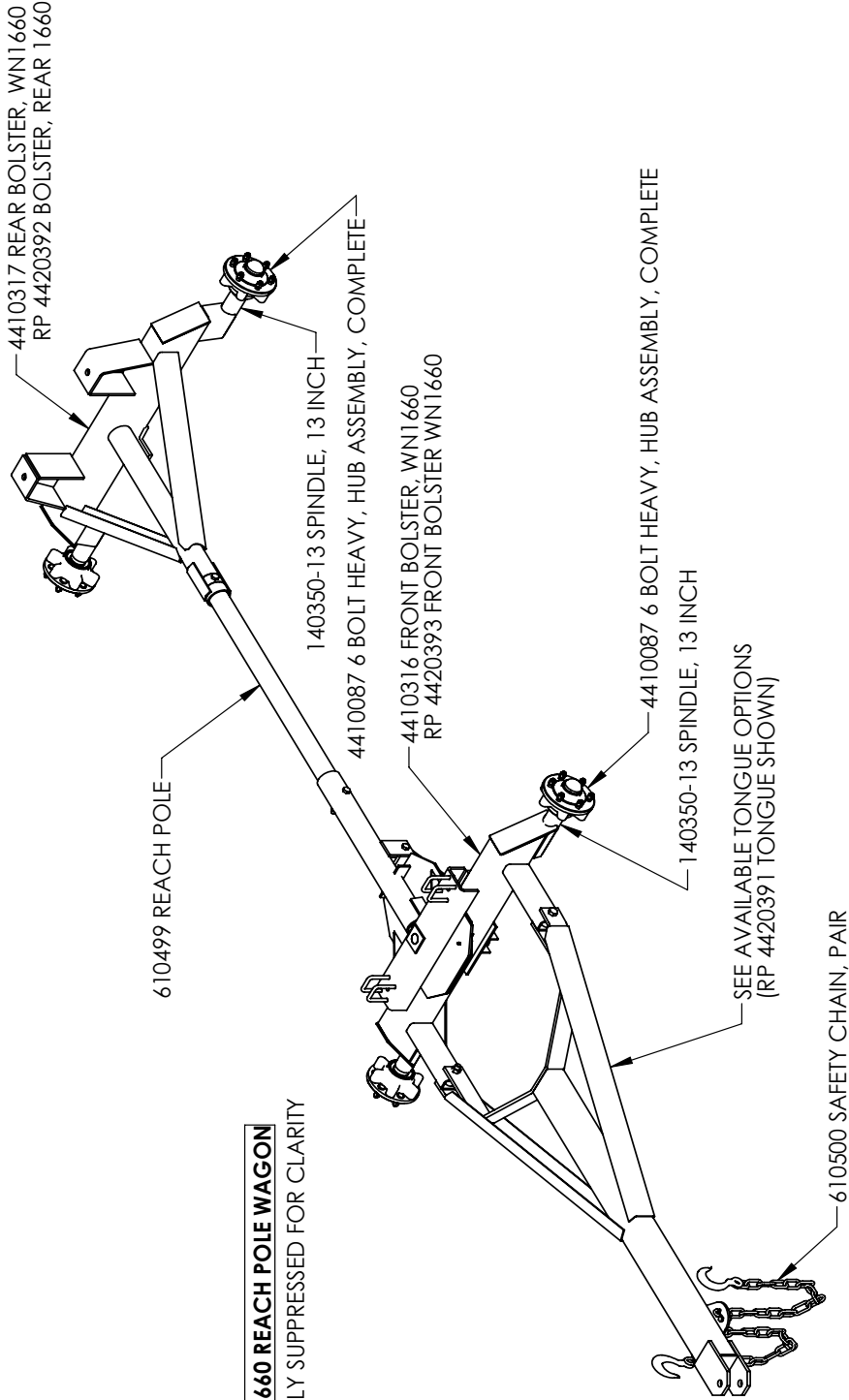

4400073 WN1660 REACH POLE WAGON

SPRING ASSEMBLY SUPPRESSED FOR CLARITY

DRAWN BY: RICH SMOTHERS CHECKED BY: PRINT DATE: 5/12/2015 CONFIG: Default COMMENTS:	3/20/2015 DWG: WN1660 REACH POLE WAGON	DALTON 602 E. VAN BUREN ST., LENOX, IA 50851	REV: A SHEET TITLE: Sheet1 SCALE: 1:24 SHEET 1 OF 1
<p>FOR PARTS, CALL 1.800.342.7498</p>			

WA1600 REACH POLE WAGON

WA1600 REACH POLE WAGON

**4400114 WA1600 REACH POLE WAGON, DOUBLE
610499-1 REACH POLE**

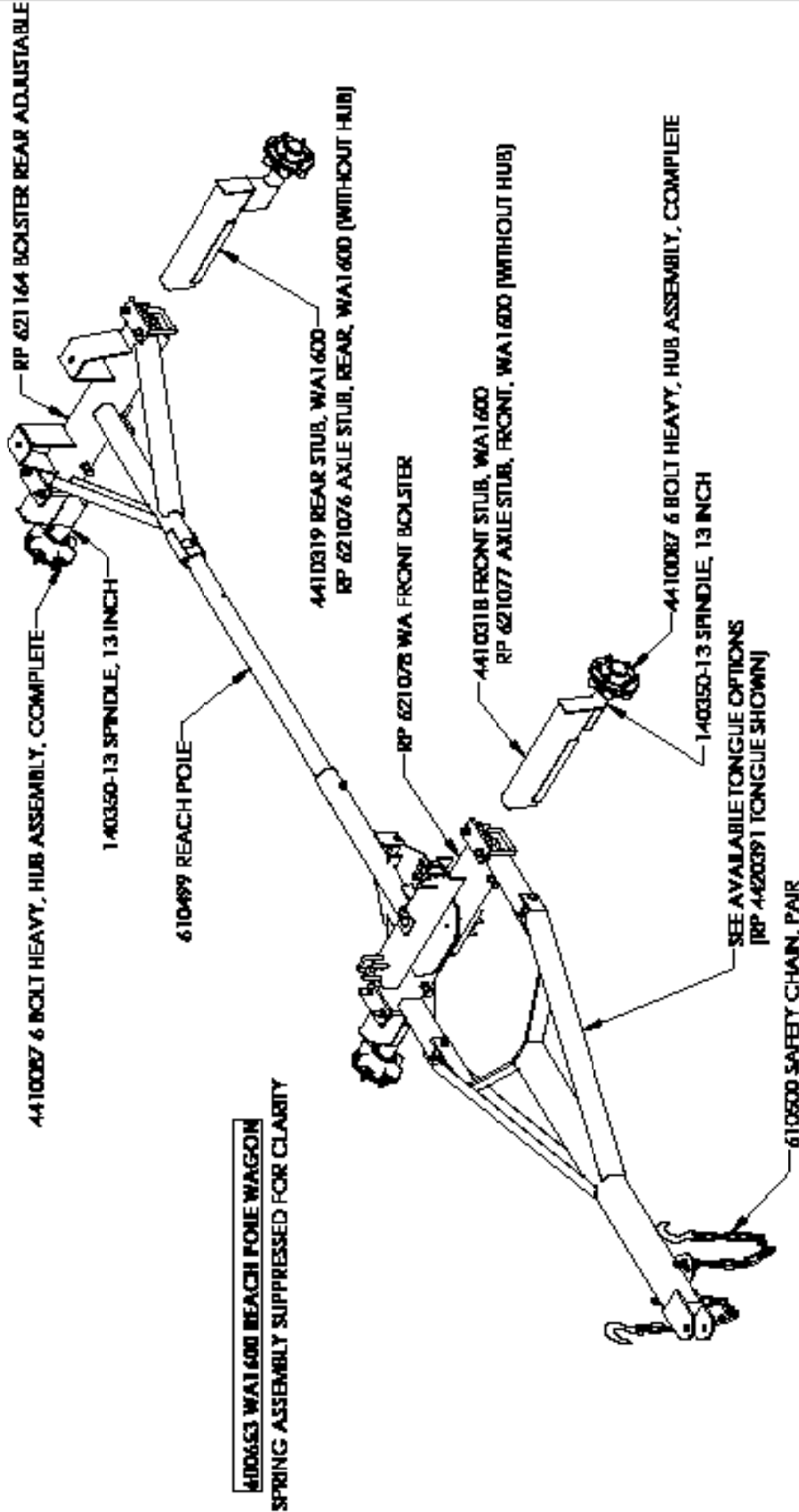

DRAWN BY BICH SMOTHERS	9/8/2014	USA DALTON CORP. LYN BURNETT, LYNOK VA 08681	DMG: WA1600 REACH POLE WAGON
CHECKED BY			SIZE SHEET TITLE A Sheet A
REVIS DATE 5/11/2015			SCALE 1:24
CONF: Default			SHEET 1 OF 1
COMMENTS:			
PROPRIETARY AND CONFIDENTIAL THE INFORMATION CONTAINED IN THIS DRAWING IS THE SOLE PROPERTY OF DALTON AND ANY REPRODUCTION IN PART OR AS A WHOLE WITHOUT THE WRITTEN PERMISSON OF DALTON IS FORBIDDEN.			
FOR PARTS, CALL 1.800.342.7478			
5	4	3	2
			1

4410087, 6-BOLT HEAVY HUB ASSEMBLY

4410087 6 BOLT HEAVY, HUB ASSEMBLY

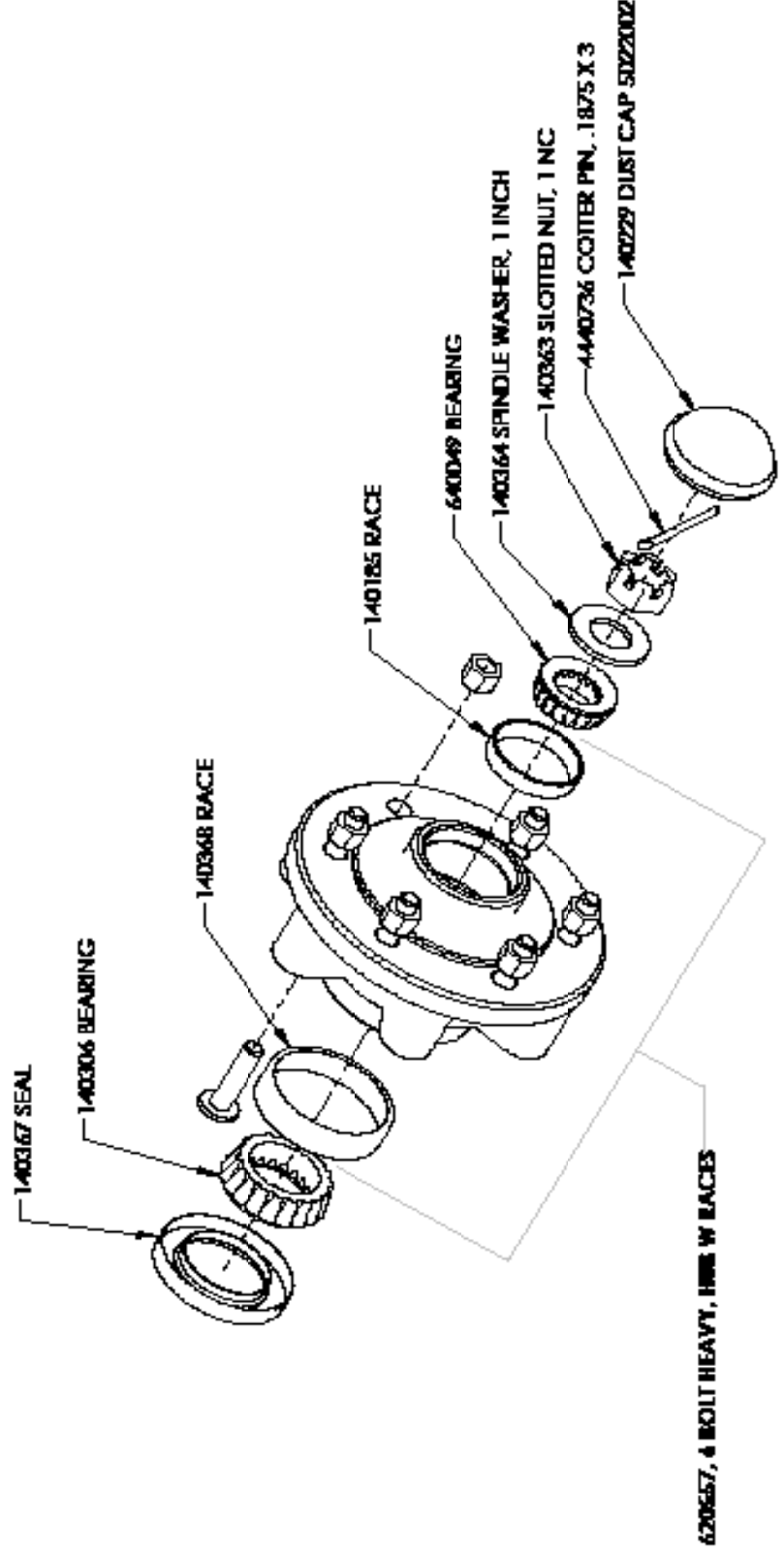

620657, 4 BOLT HEAVY, HUB W RACES

4410087 6 BOLT HEAVY, HUB ASSEMBLY, COMPLETE

640155 LUG NUT, .5 NC - QUANTITY - 6
 640154 LUG BOLT, .5 NC - QUANTITY - 6

DRAWN BY: RICH SMOTHERS CHECKED BY: PUBLISH DATE: 5/6/2015 CONFIG: EXPLODED VIEW COMMENTS:	9/4/2014 5/6/2015 EXPLODED VIEW	DALTON 4410087 6 BOLT HEAVY, HUB ASSEMBLY	SIZE: A SHEET TITLE: Sheet 1 REV: A SCALE: 1:4 SHEET 1 OF 1
FOR PARTS, CALL 1.800.342.7478			
5	4	3	2
			1

PROPRIETARY AND CONFIDENTIAL
 THE INFORMATION CONTAINED IN THIS
 DRAWING IS THE SOLE PROPERTY OF
 DALTON AND ANY REPRODUCTION IN
 PART OR AS A WHOLE WITHOUT THE
 WRITTEN PERMISSION OF DALTON IS
 PROHIBITED.

WN1800 REACH POLE WAGON

WN1800 REACH POLE WAGON

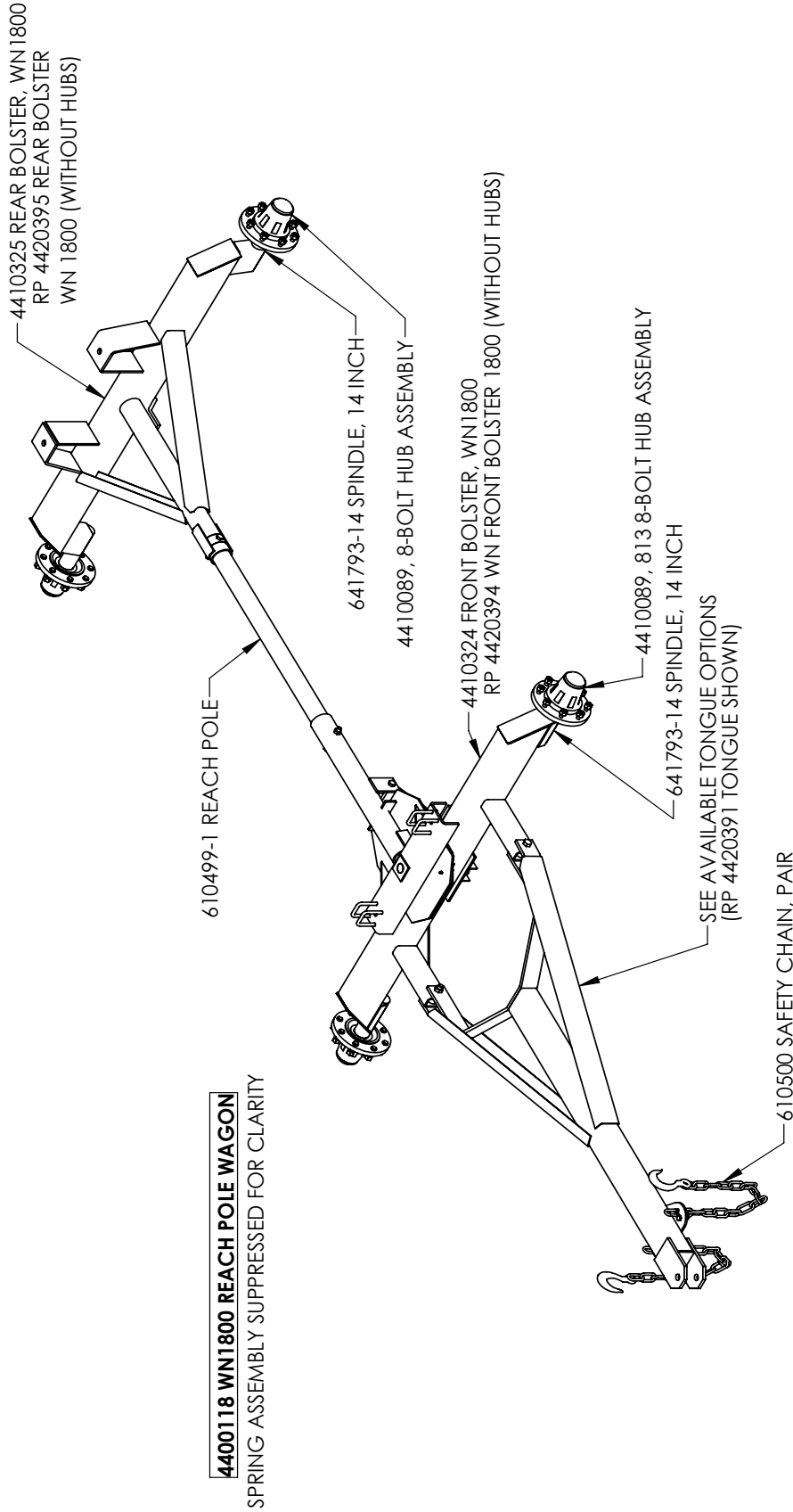

DRAWN BY	RICH SMOTHERS	9/5/2014
CHECKED BY		
PRINT DATE	5/11/2015	
CONFIG.	Default	



DWG: WN1800 REACH POLE WAGON

PROPRIETARY AND CONFIDENTIAL
THE INFORMATION CONTAINED IN THIS DRAWING IS THE SOLE PROPERTY OF DALTON A.G. ANY REPRODUCTION IN PART OR AS A WHOLE WITHOUT THE WRITTEN PERMISSION OF DALTON A.G. IS PROHIBITED.

SIZE	A	SHEET TITLE:	Sheet1	REV	A
SCALE:	1:24			SHEET 1 OF 1	

FOR PARTS, CALL 1.800.342.7498

5

4

3

2

1

WN1860 REACH POLE WAGON

WN1860 REACH POLE WAGON

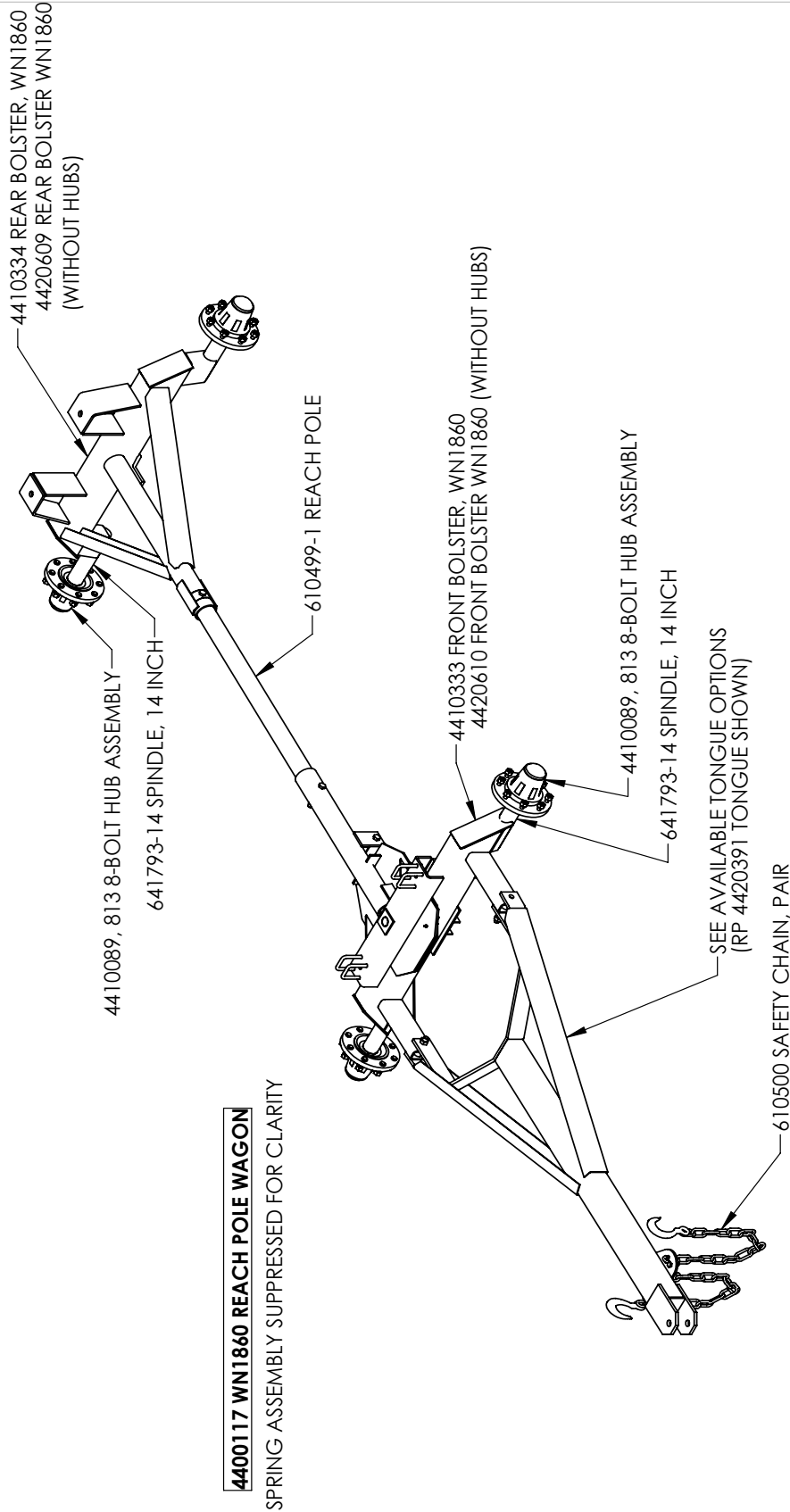

DRAWN BY RICH SMOTHERS		3/20/2015	 DALTON 602 E. VAN BUREN ST., LENOX, IA 50851	
CHECKED BY		5/11/2015		
PRINT DATE		5/11/2015	DWG: WN1860 REACH POLE WAGON	
CONFIG: Default			SIZE SHEET TITLE: Sheet1 REV A	
COMMENTS:			SCALE: 1:24 SHEET 1 OF 1	
PROPRIETARY AND CONFIDENTIAL THE INFORMATION CONTAINED IN THIS DRAWING IS THE SOLE PROPERTY OF DALTON AG. ANY REPRODUCTION IN PART OR AS A WHOLE WITHOUT THE WRITTEN PERMISSION OF DALTON AG IS PROHIBITED.		FOR PARTS, CALL 1.800.342.7498		1
		3		
		4		
		5		

WA1800 REACH POLE WAGON

WA1800 REACH POLE WAGON

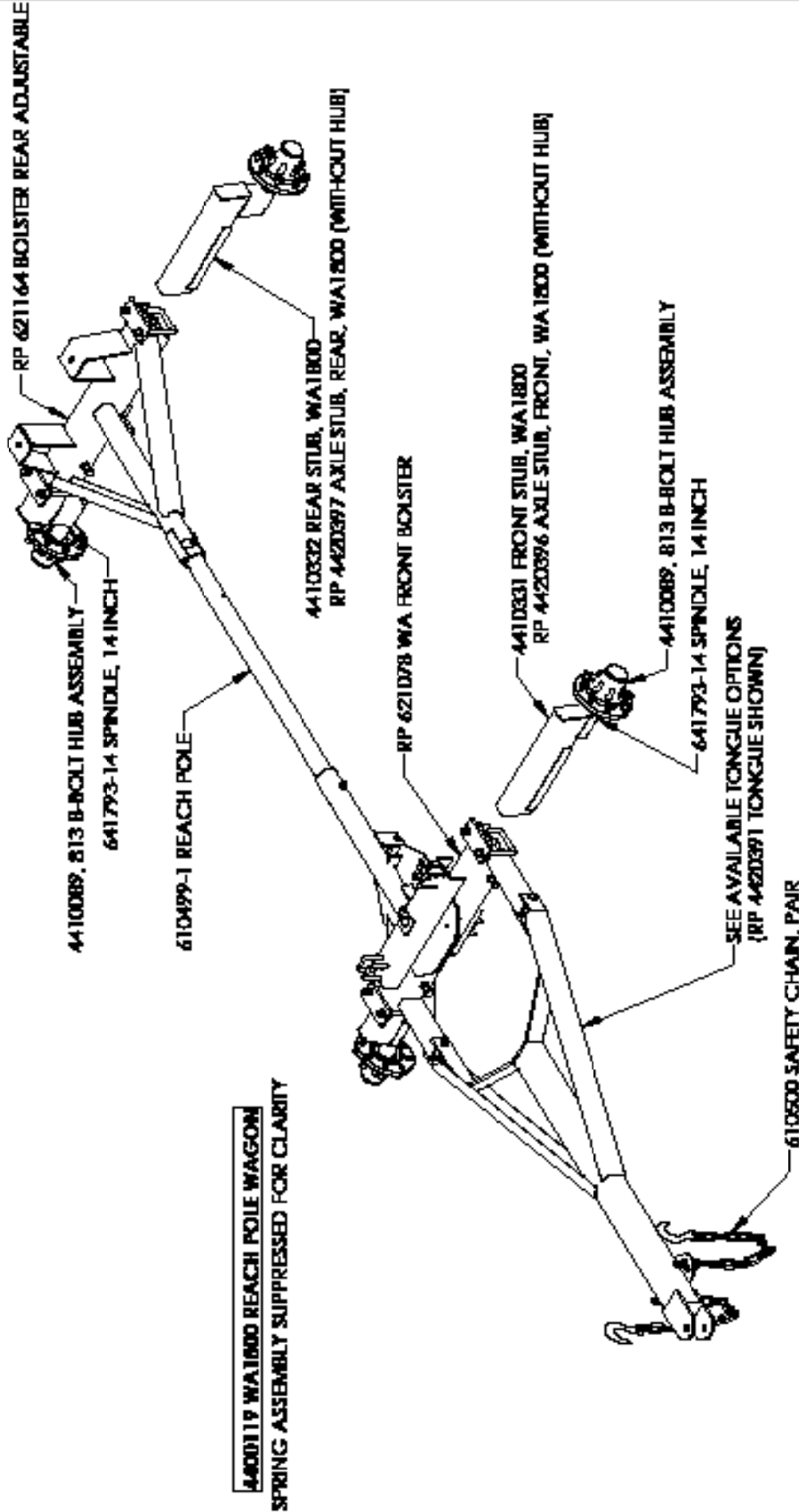

DRAWN BY: BUCH SMOTHERS CHECKED BY: REVISION DATE: 5/11/2015 CONFIG: Default COMMENTS:	9/8/2014 5/11/2015 Default COMMENTS:	DALTON USA 400 E. VAN BUREN ST., LINCOLN, VA 23060	DWG#: WA1800 REACH POLE WAGON SIZE: SHEET TITLE: A SHEET: Sheet 1 REV: A SCALE: 1:24 SHEET 1 OF 1	
PROPRIETARY AND CONFIDENTIAL THE INFORMATION CONTAINED IN THIS DRAWING IS THE SOLE PROPERTY OF DALTON AND ANY REPRODUCTION IN PART OR AS A WHOLE WITHOUT THE WRITTEN PERMISSON OF DALTON IS FORBIDDEN.				
FOR PARTS, CALL 1.800.342.7478				
5	4	3	2	1

4410089, 813 8-BOLT HUB ASSEMBLY

4410089, 813 8-BOLT HUB ASSEMBLY

4450040 HUB REBUILD KIT

- INCLUDES BEARINGS, RACES, AND SEALS

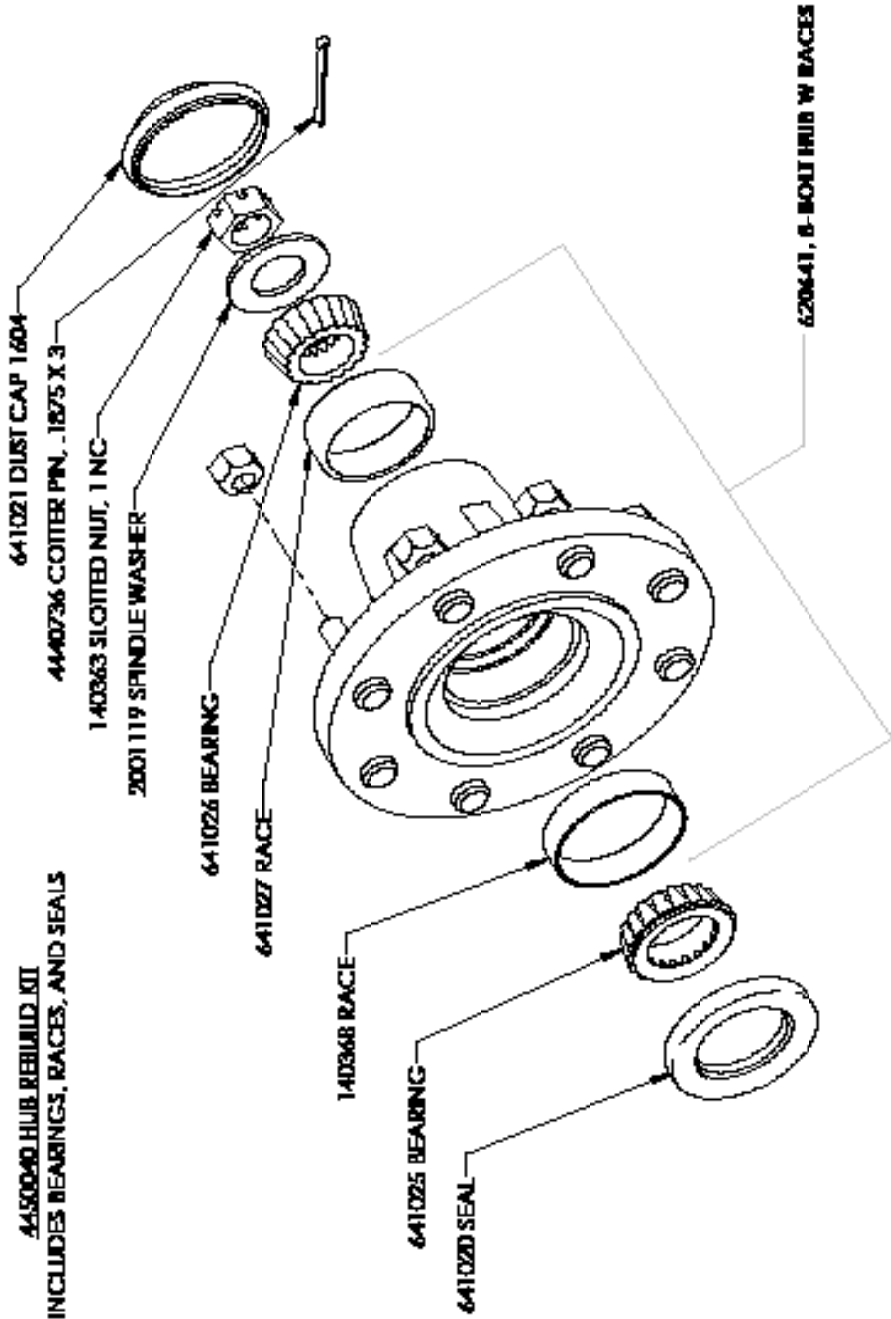

4410089, 813 8-BOLT HUB ASSEMBLY, COMPLETE

641022 LUG NUT .5625 NC - QUANTITY - 8
 641024 LUG BOLT .5625 NC - QUANTITY - 8

DRAWN BY: BCH SMOTHERS CHECKED BY: PUBLISH DATE: 4/23/2014 CONFIG: Default COMMENTS:	8/4/2009	DALTON USA 400 E. VAN BUREN ST., LINCOLN, NE 68501	DWG#: 4410089, 813 8-BOLT HUB ASSEMBLY
PROVISIONARY AND CONFIDENTIAL THE INFORMATION CONTAINED IN THIS DRAWING IS THE SOLE PROPERTY OF DALTON AND ANY REPRODUCTION IN PART OR AS A WHOLE WITHOUT THE WRITTEN PERMISSION OF DALTON IS PROHIBITED.	SIZE: A SHEET TITLE: Sheet 1 REV: A	SCALE: 1:4 SHEET 1 OF 1	1 2 3 4 5

PARTS ORDERING PROCEDURE

Your Dalton Ag dealer is interested in your new fertilizer application equipment and has the desire to help you get the most value from it. Through the help of this manual, you will find you can do some of the regular maintenance yourself. For parts and service, contact the Dalton Ag Dealership from which you purchased your fertilizer application equipment or your local Dalton Ag dealer.

When replacement parts are required, consult the applicable illustration and parts list to obtain the correct part name and number. When requesting a replacement part, always include the following information:

1. Complete Part Number
2. Description
3. Quantity Required
4. Machine and Model Number
5. Machine Serial Number - located on the topside of the frame near hitch
6. Provide complete name and address for where and how parts are to be shipped.

NOTE: Right and left hand parts and sides of the units are determined by standing at the rear and facing in the direction of forward travel.

EQUIPMENT MODEL: _____

EQUIPMENT SERIAL NO.: _____

DATE OF PURCHASE: _____

NAME OF DEALER: _____

DEALER'S PHONE NUMBER: _____

Thank you for your business!

DaltonAg.com

602 E. Van Buren Lenox, Iowa 50851
100% Employee Owned

800.342.7498

NOTES



www.daltonag.com

602 E. VAN BUREN / LENOX, IOWA 50851 / 800-342-7498