

# ANHYDROUS AMMONIA TOOLBAR

**Dalton**  
AG PRODUCTS



*DW High Speed*  
**SHADOW** series



**DISCOVER THE QUIET EFFICIENCY OF THE DALTON SHADOW**

## EXCLUSIVE FEATURES

- ◆ 6"X6" HEAVY DUTY FRAME
- ◆ ROBUST PIN ON TONGUE
- ◆ YETTER 10K MAGNUM ROW UNIT
- ◆ NO MAINTENANCE WALKER PIVOTS
- ◆ SINGLE POINT DEPTH CONTROL
- ◆ SELF LEVELING REAR HITCH
- ◆ VERSATILE CUSTOM ROW SPACING OPTIONS
- ◆ UNIVERSAL SHADOW GRAY COLOR



DALTON AG TOOLBARS

# SHADOW SERIES

## HIGH SPEED (HS)

### DW HIGH SPEED SERIES TOOLBAR SPECIFICATIONS

FEATURES	DW CLASS 1	DW CLASS 2	DW CLASS 3
Rows	11 to 14	15 to 18	19 to 23
Row Spacing	30" Standard	30" Standard	30" Standard
Custom Row Spacing	Optional	Optional	Optional
Working Width	Up to 35'	Up to 45'	57.5'
Center Section Width	13'	13', 14', 15.5'	15.5', 16'
Frame Tubing	6" x 6"	6" x 6"	6" x 6"
Rank	54"	54"	54"
Heavy Duty Pin On Adjustable Tongue	6" x 6"	6" x 6"	6" x 6"
Hitch	CAT4 Bull Pull	CAT4 Bull Pull	CAT4 Bull Pull
Telescoping/Swinging HD Self- Leveling Rear Hitch	Standard	Standard	Standard
Wing Sections	3 Sections	3 or 5 Sections	5 Sections
Quick Coupler Stand	Standard	Standard	Standard
Tires	320/70 R15	320/70 R15	320/70 R15
Axles - Lift & Gauge Wheels	Walker	Walker	Walker
Hydraulic Outboard Gauge Wheels	N/A	Hydraulic	Hydraulic
Greaseless Primary Pivot Points	Standard	Standard	Standard
Hydraulic Hose & Gauge Stand	Standard	Standard	Standard
Light Kit	Standard	Standard	Standard
HP Requirement (Typical Application)	165-280	225-360	285-460
2 Year Main Frame Warranty	Standard	Standard	Standard
Row Units	Yetter 10K Magnum	Yetter 10K Magnum	Yetter 10K Magnum

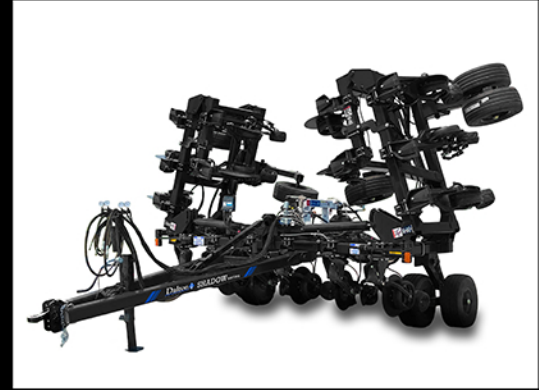

**TOOLBAR TRAVELING POSITION**



**Yetter Magnum 1000**



**SELF-LEVELING REAR HITCH**



Manufactured by:



602 E. Van Buren  
Lenox, Iowa 50851

office@daltonag.com

1-800-342-7498

www.DaltonAg.com

**SEE YOUR LOCAL DEALER**

