



OPERATING AND PARTS MANUAL

WIDE SPREAD SPREADERS

6, 8, 10 & 12 Ton

2024



TABLE OF CONTENTS

TO YOU THE OWNER.....	1
LIMITED WARRANTY STATEMENT.....	2
NEW MACHINE CHECKOUT.....	3
OPERATION AND SAFETY.....	4
LUBRICATION SCHEDULE.....	5
LUBRICATION DETAIL.....	6
BOLT TORQUE CHART.....	7
MACHINE ADJUSTMENT.....	8
SPECIFICATIONS.....	9
SPREAD ADJUSTMENT AND APPLICATION RATES.....	10
SPREAD PATTERN DETAILS.....	11
60' SPREAD SETUP.....	12
90' SPREAD SETUP.....	13
DISTRIBUTOR BLADE TUNING.....	14
DISTRIBUTOR BLADE TUNING, WIDE SPREAD.....	15
60' SPREAD PATTERN DECAL.....	16
90' SPREAD PATTERN DECAL.....	17
60' OR 90' SPREAD PATTERN DECAL, VARIABLE RATE.....	18
FRAME AND DRIVELINE.....	19
540 PTO.....	20
1000 PTO.....	21
6 TON AXLE/HUB PARTS.....	22
8 TON AXLE /HUB PARTS.....	23
10 & 12 TON AXLE/HUB PARTS.....	24
GROUND DRIVE ASSEMBLY.....	25
BOLT ON GROUND DRIVE.....	26
FRONT TANK ASSEMBLY.....	27
GATE JACK ASSEMBLY.....	28
REAR AREA ASSEMBLY.....	29
REAR AREA ASSEMBLY CONT.....	30
DISTRIBUTOR GEAR BOX.....	31
HYDRAULIC SPINNER GEAR BOX.....	32
TRACTOR HYDRAULIC DRIVEN SPINNERS.....	33
HYDRAULIC SPINNER DRIVE LAYOUT.....	34
DIGITAL READOUT.....	35
VARIABLE RATE CONTROL, ELECTRICAL PLAN.....	36
VARIABLE RATE CONTROL, HYDRAULIC PLAN.....	37
INITIAL ASSEMBLY HARDWARE, FREIGHT SHIPPING.....	38
LOAD CELL & JUNCTION BOX MOUNTING.....	39
SPREADER CONSTANT VALUE.....	40
CALIBRATION NUMBERS FOR VARIABLE RATE SPREADERS 360 ENCODER.....	41
GATE MARKER DECAL.....	42
DECAL LAYOUT.....	43
DECAL LAYOUT.....	44
PARTS ORDERING PROCEDURE.....	45

TO YOU, THE OWNER

Your Dalton Ag Equipment is the most modern, up-to-date, versatile, machine available for fertilizer application. The machine is the result of many years of experience, research, development and testing of equipment for fertilizer application. It is soundly engineered and carefully built to rigid specifications. It is of rugged and simple construction, with a minimum of moving parts.

However, to obtain maximum performance from your Dalton Ag Equipment, it is necessary to follow the instructions and safety suggestions in this manual. Each section has been carefully prepared for the purpose of providing needed and valuable information to the owner and operator. Each operator of this unit should be familiar with the contents of this manual. Keep it in a safe and convenient location. THERE ARE MANY SAFETY SUGGESTIONS (CAUTION AREAS) PRINTED THROUGHOUT THIS MANUAL. CAREFULLY READ THEM ALL BEFORE OPERATING THIS UNIT.

DESIGN IMPROVEMENTS

Dalton Ag Products follows a policy of continuous products improvement. We therefore reserve the right to make design improvements, and changes in specifications and prices, without incurring obligations to make revisions or additions to equipment previously sold.

**REGISTER
WARRANTY
ONE OF
FOUR WAYS**

- Register on-line at:
www.daltonag.com
- Fax your completed warranty registration form to:
641-569-7033
- Email your completed warranty registration form to:
office@daltonag.com
- Mail your completed warranty registration form to:
Dalton Ag, Inc.
P.O. Box 70
Lenox, IA 50851

LIMITED WARRANTY STATEMENT

DALTON AG PRODUCTS warrants to the original purchaser only that all products manufactured under the Dalton Ag and Mobility Brands will be free from defects in material and workmanship under normal use and service.

DALTON AG’s obligation under this warranty is limited to repairing or replacing, as it may elect, free of charge and without charge for installation, at the place of business of a dealer or distributor authorized to handle the equipment covered by this warranty or at a DALTON AG facility, any parts that prove, in DALTON AG's judgment, to be defective in material or workmanship within two (2) years after delivery to the original purchaser. DALTON AG shall not be liable for personal injuries or any special or consequential damages of any kind, either direct or indirect. This warranty is subject to acts of God, fire and existing conditions of supply and demand, production, ability or inability to deliver, or for any other valid reason beyond the reasonable control of DALTON AG. No distributor, dealer, agent or DALTON AG employee (other than DALTON's President in writing) is authorized to extend or make any other or further express or implied warranty or incur any additional obligation on DALTON AG’s behalf in connection with the sale of this product.

Customer Responsibility

Product Registration - It is a condition of this warranty that the original purchaser fill out the warranty card furnished by DALTON AG and return it to DALTON AG to be recorded in DALTON AG’s owner file. Registration may also be done on line at www.DaltonAg.com/warrantyregistration. If the original purchaser's card or electronic registration is not on file at DALTON AG’s office, the warranty period will extend only from date equipment was picked up or shipped from the DALTON AG plant.

Maintenance - It is the customer’s responsibility to maintain their equipment in accordance with the instructions provided in the Operator’s Manual. DALTON AG recommends that you keep records and receipts as the customer may be required to verify the maintenance instructions have been followed.

Operation – It is the customer’s responsibility to operate the equipment only for the purpose for which it was designed and in accordance with all safety and operational recommendations contained in the Operator's Manual. If a defect in materials or workmanship occurs, it is the customer’s responsibility to cease operating the equipment until authorized repairs are made.

Damage incurred from continued operation after a defect is discovered may not be covered by this warranty.

What this Warranty Covers

This warranty covers failures caused by defects in materials or workmanship only.

This Warranty does not cover failures caused by:

- Improper operation
- Natural calamities
- Unauthorized modifications
- Unauthorized repairs
- Use of Non DALTON AG parts
- Neglected maintenance
- Usage contrary to the intended purpose of the product

This Warranty does not cover replacement of Wear or Maintenance Items including, but not limited to:

- Lubricants
- Filters
- Hoses
- Tires
- Disks
- Chains
- Idlers
- Blades
- Belts
- Bearings

This Warranty does not cover:

- Pickup and delivery of the equipment
- Service Calls or Travel Time to and from sites
- Rental of replacement equipment during repair period
- Products that have been declared a total loss and subsequently salvaged
- Overtime labor charges

Parts Warranty

DALTON AG warrants its replacement parts against defects in materials or workmanship for a period of 90 days or the remainder of the product warranty, whichever is longer under the terms set out above. Remedy for defective replacement parts for units that are beyond the original product warranty, will be limited to replacement of the failed part.

NEW MACHINE CHECKOUT

Before attempting to use or operate the spreader it is important to be thoroughly familiarized with the contents of this manual. Then the machine should be checked using the following check list:

1. Ground drive tire inflated to 22 PSI. Tires inflated to manufacturing specifications.
2. All bearings lubricated and tightly mounted with collars securely locked.
(See lubrication schedule page 5.)
3. Conveyor chains, drive chain & ground drive chain adjusted to correct tension. Conveyor chain should be flush or just below the bottom of the trough in the area approximately 2' behind the front roller.
4. Sprockets tightened & in proper alignment.
5. Inspect entire machine for loose bolts, especially in the spinner assembly and drive line area.
6. Distributor fan blades set properly. (See spread adjustment and application rates)
7. Place 1/2" material on top of chain, lower gate to material, set pointer at 1".
8. Tighten wheel bolts daily – 95 foot pounds single axle spreaders.
9. Check drive line for ease of operation by turning shaft by hand. If the foregoing inspection reveals that additional lubrication or adjustment is required, refer to the proper section of this manual for detailed instructions.
10. Ground drive wheel and universal joint shear pins in place and tight.
11. Check both spinner gear boxes for oil; fill to level of pipe plug with SAE No. 90 non-detergent oil.

OPERATION

SPREADER SAFETY

Before starting in motion please read the following words of caution.

- A. It is recommended that initial spreading be done in as low a range as possible to permit easy break-in.
- B. Always shut off or disconnect power to spreader before attempting to repair or adjust the spreader.
- C. Do not transport machine with ground drive wheel engaged.
- D. NEVER back-up spreader with ground drive wheel engaged.
- E. Make sure that the towing vehicle brakes are operating properly and are capable of stopping the towing vehicle.
- F. If a pick-up is used as the towing vehicle, it is wise to add ballast for additional safety and traction. We recommend that all towing vehicles be ballast loaded to their recommended G.V.W.
- G. Hitches should be of heavy construction and should be welded or bolted directly to the towing vehicle frame. Hitches should be checked routinely for loose bolts, cracked welds, etc.
- H. Never tow a spreader with a drawbar pin less than 1" in diameter. Pins should also have a locking device.
- I. Do not tow spreader at speeds in excess of 20 mph loaded or 40 mph empty.
- J. Remember, that the stopping and braking distances vary with load and vehicle speed. It is well to familiarize yourself with the characteristics of your machine under different load and speed conditions.
- K. Be sure to attach safety break-away chain and the safety chain to towing vehicle to assure control of spreader in the case of pin or hitch failure.
- L. The unit is designed for hitching to vehicles with drawbar heights between 12 and 18 inches above the ground level. It will operate with all standard tractor hitches and PTO's. WARNING: Hydraulically mounted drawbars must be securely and mechanically locked because a fully loaded spreader applies a load in the order of 2000 lbs. to the hitch.
- M. WARNING: Remember this unit is designed for agricultural use only and is primarily an off-the-road vehicle and should be towed at tractor speeds ONLY, not to exceed 20 mph loaded or 40 mph empty. Inspect hubs routinely to see if they are heating, which indicates either a need for lubrication or improper adjustment of brakes or bearings, also check stud nuts for tightness.
- N. WARNING: The maximum capacity of this unit is 8 tons (800) or 270 cubic feet and 10 tons (1000) or 333 cubic feet, based on a material density of 60 pounds per cubic foot. DO NOT EXCEED THIS LIMIT!

OPERATING INSTRUCTIONS

Please read the following completely before spreading.

- 1) Attach spreader to towing vehicle, make sure hitch and hitch pin are sound.
- 2) Attach PTO shaft to proper rpm PTO.
- 3) Spinner discs, adjustable chute and conveyor floor should be clean for accurate metering.
- 4) Set metering gate to desired spread rate according to decal on the back end sheet of tank. Always keep the machine in the lowest possible range.
- 5) Before starting to spread, rotate the ground drive wheel several revolutions by hand to make sure the conveyor chain is operating freely. If chain is frozen or moves with too much resistance, correct problem before using spreader.
- 6) If the ground drive wheel operates properly, check with chain and sprocket arrangement for desired range setting and chain tension.
- 7) When spreading is complete, disengage ground drive assembly from the tire and install transport lockup.

LUBRICATION SCHEDULE

DAILY LUBRICATION SCHEDULE	DRIVELINE	ALL MODELS	(4) BEARINGS
			(2) U-JOINTS
		GROUND DRIVE	(1) BEARING
			(4) U-JOINTS
			(2) TELESCOPING TUBES
	CONVEYOR DRIVE	ALL MODELS	(6) BEARINGS
	GROUND DRIVE	ALL MODELS	(2) SHAFT HOUSINGS
			(2) U-JOINTS
TELESCOPING TUBE			
(2) SQUIRTS OF SAE 90 OIL INTO JACK CRANK			
		OIL CAP	

Pay particular attention to the daily cleaning and greasing of the telescoping tube assembly.

WEEKLY LUBRICATION SCHEDULE	CHAINS	OIL	LUBRICATE PIN JOINTS WITH SAE 80-90
	PTO SHAFT	GREASE	(2) U-JOINTS AND SLIP TUBE
	SPINNER GEARBOX	GREASE	UNIVERSAL GREASE ON EACH FITTING UNDER SPINNER HUB

MONTHLY LUBRICATION SCHEDULE	DRIVE SHAFT SPLINES	COAT WITH GREASE OR ANTI-SEIZE COMPOUND
	SPINNER GEAR BOX	CHECK TO SEE THAT OIL LEVEL IS UP TO OIL LEVEL PLUG. USE SAE 90 OIL

ANNUAL LUBRICATION SCHEDULE	WHEEL BEARINGS	REPACK
	GEAR BOXES	DRAIN, FLUSH, AND REFILL WITH SAE 90 OIL

MAINTENANCE SCHEDULE

WEEKLY	WASH SPREADER
	CHECK GROUND DRIVE TIRE INFLATION (22 PSI)
	CORRECT BELT TENSION
	ADJUST TENSION OF CONVEYOUR AND DRIVE CHAINS (SEE MACHINE CHECKOUT)

SEMI-ANNUALLY	TIGHTEN LOOSE BOLTS
	REPLACE WORN OR FAILED PARTS
	TOUCH-UP PAINT

LUBRICATION DETAIL

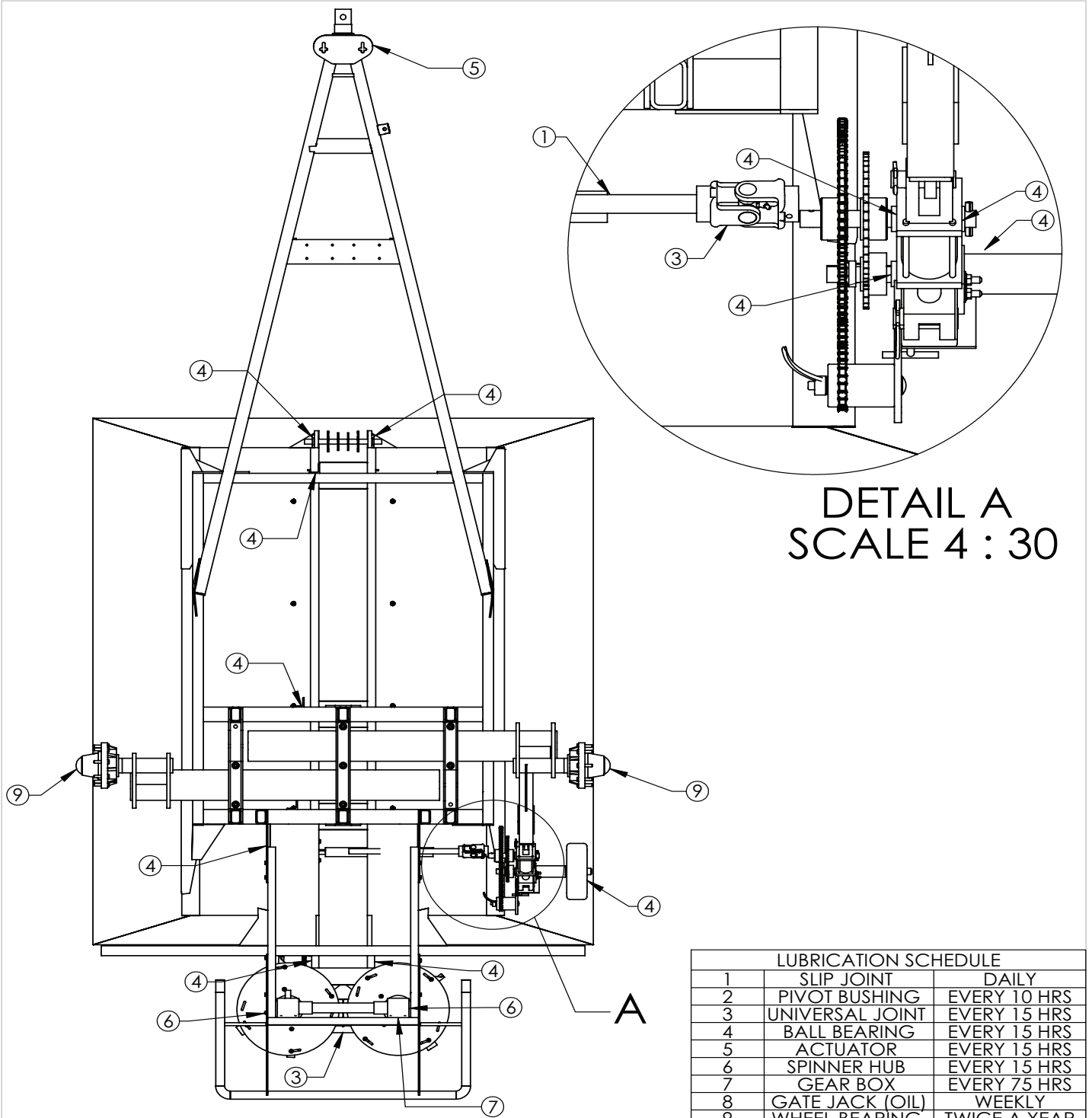

DETAIL A
SCALE 4 : 30

LUBRICATION SCHEDULE		
1	SLIP JOINT	DAILY
2	PIVOT BUSHING	EVERY 10 HRS
3	UNIVERSAL JOINT	EVERY 15 HRS
4	BALL BEARING	EVERY 15 HRS
5	ACTUATOR	EVERY 15 HRS
6	SPINNER HUB	EVERY 15 HRS
7	GEAR BOX	EVERY 75 HRS
8	GATE JACK (OIL)	WEEKLY
9	WHEEL BEARING	TWICE A YEAR

DRAWN BY	RICH SMOTHERS	2/9/2010
CHECKED BY		
PRINT DATE	7/28/2014	
CONFIG.	Default	
COMMENTS:		







PROPRIETARY AND CONFIDENTIAL
THE INFORMATION CONTAINED IN THIS DRAWING IS THE SOLE PROPERTY OF DALTON AG. ANY REPRODUCTION IN PART OR AS A WHOLE WITHOUT THE WRITTEN PERMISSION OF DALTON AG IS PROHIBITED.

DWG:	LUBRICATION SCHEDULE	
SIZE	SHEET TITLE:	REV
A	Sheet1	A
SCALE: 1:26	SHEET 1 OF 1	

FOR PARTS, CALL 1.800.342.7498

IMPORTANT : Over tightening hardware can be as damaging as under tightening. Tightening beyond recommended torque will reduce the fastener's shock load capacity.

BOLT TORQUE CHART

SIZE	 SAE GRADE 2		 SAE GRADE 5		 SAE GRADE 8		 L9
	ASSEMBLY TORQUE DRY	LUBRICATED	ASSEMBLY TORQUE DRY	LUBRICATED	ASSEMBLY TORQUE DRY	LUBRICATED	ASSEMBLY TORQUE LUBRICATED
1/4-20	66*	49*	8	75*	12	9	11
1/4-28	76*	56*	10	86*	14	10	13
5/16-18	11	8	17	13	20	18	21
5/16-24	12	9	19	14	25	20	23
3/8-16	20	15	30	23	45	30	33
3/8-24	23	17	35	25	50	35	38
7/16-14	30	24	50	35	70	55	60
7/16-20	35	25	55	40	80	60	65
1/2-13	50	35	75	55	110	80	95
1/2-20	55	40	90	65	120	90	105
9/16-12	65	50	110	80	150	110	140
9/16-18	75	55	120	90	170	130	150
5/8-11	90	70	150	110	220	170	185
5/8-18	100	80	180	130	240	180	205
3/4-10	160	120	260	200	380	280	290
3/4-16	180	140	300	220	420	320	355
7/8-9	190	140	400	300	600	460	505
7/8-14	210	155	440	320	660	500	585
1-8	220	160	580	440	900	680	775
1-14	240	170	640	480	1000	740	900
1 1/8-7	300	220	800	600	1280	960	1150
1 1/8-12	340	260	880	660	1440	1080	1325
1 1/4-7	420	320	1120	840	1820	1360	1600
1 1/4-12	460	360	1240	920	2000	1500	1750
1 3/8-6	560	420	1460	1100	2380	1780	---
1 3/8-12	640	460	1680	1260	2720	2040	---
1 1/2-6	740	560	1940	1460	3160	2360	3250
1 1/2-12	840	620	2200	1640	3560	2660	3650

**ITEMS WITH * = INCH POUNDS
ALL OTHERS = FOOT POUNDS**

WARNING: Never work around any raised implement while in the raised position without using safety lockups.

MACHINE ADJUSTMENT

WHEEL BEARING ADJUSTMENT

After repacking or when inspecting wheel bearings, the following adjustment procedure should be followed. Place flat washer and spindle nut on spindle. Turn hub as you tighten nut. When a pronounced drag is felt in the bearings, back off nut one complete slot. If necessary continue to back off the nut until the next slot aligns with the cotter pin hole and install cotter pin and dust cap.

CONVEYOR CHAIN ADJUSTMENT

Loosen chain take-up locking nuts on outside of front end of trough. Adjust take-up bolts evenly until chain clears main frame members and axle tube by $\frac{3}{4}$ " $\frac{1}{2}$ ". Inspect shaft bearing mounting bolts and shaft locking collars for tightness of set screws (6 places). Reset take-up locking nuts.

STORAGE

Before storing the spreader for more than a few days, the machine should be emptied completely and thoroughly washed both inside and out. This precaution will minimize the severity of fertilizer acid corrosion, extend the useful life of the machine, and prevent damage to drive line and conveyor chain from fertilizer compaction and caking. We further recommend that the machine be thoroughly greased after washing.

Before operating the machine after extended periods of storage, re-lubricate the entire spreader in accordance with the lubrication section of this manual. Also check the entire spreader, following the New Machine Checkout Procedure to be found in a foregoing section of the manual.

Remember that oil and grease are your least expensive corrosion inhibitors.

ADDITIONAL INSTRUCTIONS:

CAUTION

Do not operate your spreader with less than one and a half (1 1/2) inch of metering gate opening as material will compact against metering gate and cause failure of the conveyor chain.

CAUTION

Do not disconnect implement from tractor with material remaining in box.

WIDE SPREAD SERIES SPREADER SPECIFICATIONS				
FEATURES	MOBILITY 600	MOBILITY 800	MOBILITY 1000	MOBILITY 1200
Capacity (Weight)	6 Tons	8 Tons	10 Tons	12 Tons
Hopper Length	120"	120"	152"	152"
Hopper Width	93"	93"	102"	102"
Hopper Capacity (Volume)	200 cu. ft.	270 cu. ft.	335 cu. ft.	400 cu. ft.
Overall Length	230"	230"	263"	263"
Overall Width	107"	96"	102"	128" (floaters)
Overall Height	96"	120"	121"	128"
Ground Clearance	45" under Spinners 37" under Frame	48" Under Spinners 38" Under Frame	48" Under Spinners 38" Under Frame	48" Under Spinners 38" Under Frame
Spread Pattern	Up to 90'	Up to 90'	Up to 90'	Up to 90'
Hopper Construction	409 Stainless Steel	409 Stainless Steel	409 Stainless Steel	409 Stainless Steel
Spinner Drive System	540/1000 PTO: Standard Tractor Hydraulic: Optional	540/1000 PTO: Standard Tractor Hydraulic: Optional	Tractor Hydraulic: Standard	Tractor Hydraulic: Standard
Spinners	Dual Gearbox Driven	Dual Gearbox Driven	Dual Gearbox Driven	Dual Gearbox Driven
Axle	72" - 120" adjustable	80" - 120" Adjustable	82" - 120" Adjustable	82" - 120" Adjustable
Hitch	HD Clevis: Standard CAT4 Bull Pull: Optional	HD Clevis: Standard CAT4 Bull Pull: Optional	CAT4 Bull Pull	CAT4 Bull Pull
Conveyor Drive	2 SPD Ground Drive or Hydraulic	2 SPD Ground Drive or Hydraulic	2 SPD Ground Drive or Hydraulic	2 SPD Ground Drive or Hydraulic
SRT Roll Tarp	Standard	Standard	Standard	Standard
Tires & Wheels	320/90/R42	380/90/R46	380/90/R46 Duals: Optional Floaters: 850/50 R30.5 Optional	VF 380/90/R46 Duals: Optional Floaters: 850/50 R30.5 Optional
Light Kit	Standard	Standard	Standard	Standard
Variable Rate Ready	Optional	Optional	Standard	Standard
Scale Kit with Monitor	Optional	Optional	Optional	Optional
Powder Coat Paint	White	White	White	White
Warranty	24 Months	24 Months	24 Months	24 Months

CAUTION

1. Keep all shields in place.
2. Stop engine before leaving operator's position to adjust, lubricate, clean, or unclog machines.
3. Wait for all movement to stop before servicing the machine.
4. Keep hands, feet and clothing away from power driven parts.
5. Keep off equipment unless seat or platform for operation or observation is provided.
6. Make certain everyone is clear of machine before starting.

PART No. 140959

SPREAD ADJUSTMENT AND APPLICATION RATES

For accurate and precise spreading rates, it is necessary that you know the weight in pounds per cubic foot of the material to be spread. If this is not known, the weight can be quickly and accurately determined by the following method:

1. Weigh an empty one gallon container.
2. Fill level full with the material to be used.
3. Weigh container and material, and then subtract the weight of the container to obtain the weight of the material.
4. Multiply the weight of the material by 7.5 to obtain the weight of the material in pounds per cubic foot.

Example: Typical Material-Potash

1) Weight of empty one gallon container	1.00 lbs.
2) Weight of filled container	10.35 lbs.
3) Weight of container (net)	9.35 lbs.
4) 9.35×7.5	70.125 lbs. /cu ft.

You would therefore use the column on the Spread Chart headed 70 to determine the proper gate opening for the desired application rate.

Your Mobility Spreader with its heavy-duty distributor discs and blades will apply most materials in a 50 foot wide swath.

SPREAD PATTERN DETAILS

An operational characteristic of this type of machine is the possibility of overloading the distributors at high rates of application. Such an overload results in an alteration of the spread pattern to a narrower swath with heavier application at the center. This can be avoided by reducing speed when using high application rates. Caution: Be extra careful to check your spread pattern when using high application rates. Adjust your driving pattern to the actual delivered spread swath, the adjustment of the machine, and the material being used. When application rates are in excess of 700 pounds per acre, the ground speed should be proportionately reduced. We recommend that for very high application rates, to insure uniformity of application, that two lighter application passes be made preferably placing your second pass over the lap lines of the first pass. This also is recommended practice when spreading under very windy conditions or with a material that segregates easily. If your effective spread pattern is more, the Metering Gate setting should be increased proportionately, according to the percentage of your spread width. The gate setting should likewise be decreased if your effective spread pattern is less. Your spread pattern can be checked accurately and visually on a freshly worked, level area of ground. Such an area is also ideally suited to adjusting and fine tuning your machine. The following diagram graphically illustrates a typical spread pattern.

Note on the illustration below that the lap point occurs at the point where the application rate is one-half of the spread chart rate. The profile of the spread pattern tapers at both edges and has a wide uniform area in the center. By careful attention to the lap point during application, a very uniform and even spread rate can be attained. The Mobility Spreaders have been designed to provide this good and uniform tapered profile to make spread width less critical. However, excessive or insufficient overlap of passes will result in a poor application pattern in the lap area of the total spread pattern. If you can attain this spread pattern and pay careful attention to the lap points, the dotted line on the illustration will represent your actual overall spread pattern.

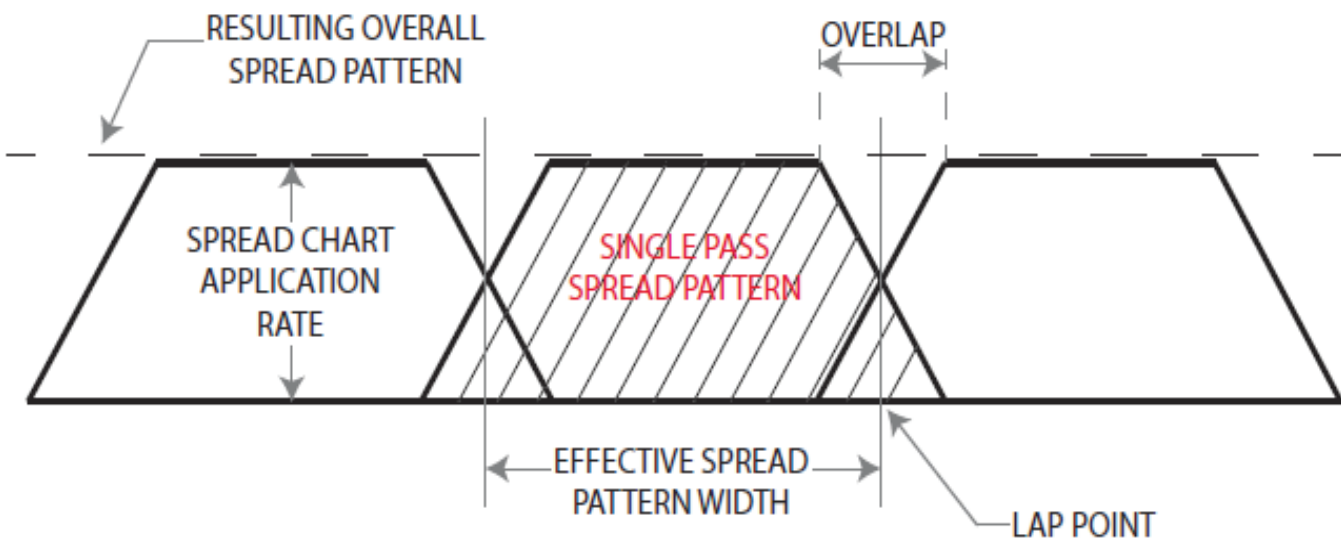

60' SPREAD SETUP

ITEM NO.	PART NUMBER	DESCRIPTION	QTY.
1	4431277-L	SPINNER BLADE, 11 INCH, LH	6
2	4431277-R	SPINNER BLADE, 11 INCH, RH	6

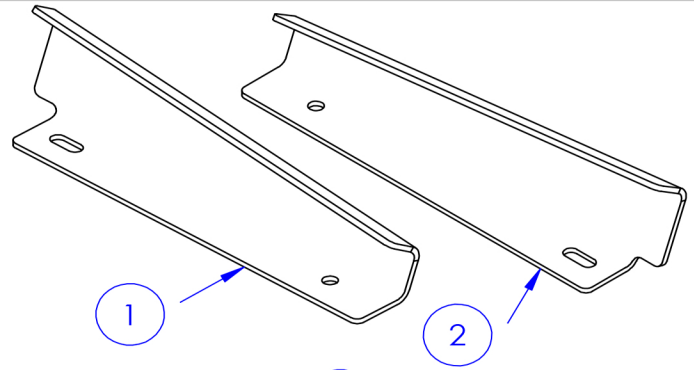

BLADES LABELLED (1) SET TO 2ND HOLE FROM LEFT SIDE OF PATTERN, VIEWED FROM THE CENTER OF THE DISC.

BLADES LABELLED (2) SET TO 2ND HOLE FROM RIGHT SIDE OF PATTERN, VIEWED FROM THE CENTER OF THE DISC.

BLADES LABELLED (2) SET TO 3RD HOLE FROM LEFT SIDE OF PATTERN, VIEWED FROM THE CENTER OF THE DISC.

BLADES LABELLED (1) SET TO 3RD HOLE FROM RIGHT SIDE OF PATTERN, VIEWED FROM THE CENTER OF THE DISC.

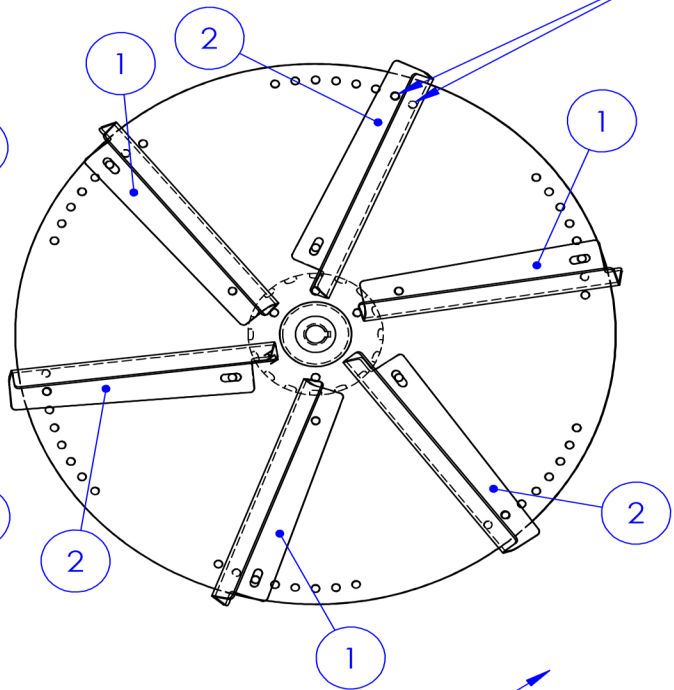
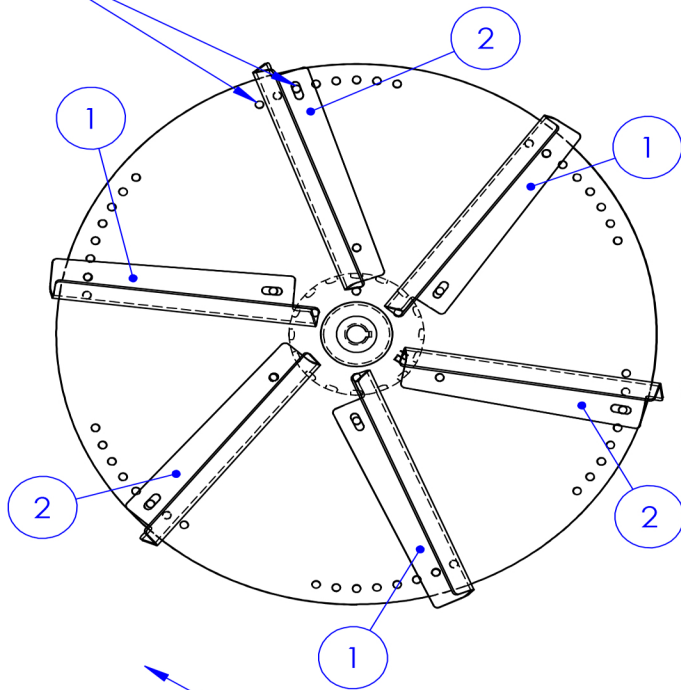

4410815-L
COMPLETE SPINNER & BLADE SET (LEFT)

4410815-R
COMPLETE SPINNER & BLADE SET (RIGHT)

VIEWED FROM BACK OF SPREADER

DRAWN BY	--	3/12/2021
CHECKED BY		
PRINT DATE	8/13/2024	
CONFIG.	60' SPREAD	



PROPRIETARY AND CONFIDENTIAL
THE INFORMATION CONTAINED IN THIS DRAWING IS THE SOLE PROPERTY OF DALTON AG. ANY REPRODUCTION IN PART OR AS A WHOLE WITHOUT THE WRITTEN PERMISSION OF DALTON AG IS PROHIBITED.

COMMENTS:

DWG: SPREAD SET UP, WIDE SPREAD

SIZE	SHEET TITLE:	REV
A	60' SPREAD	A

SCALE: 1:6 SHEET 2 OF 2

FOR PARTS, CALL 1.800.342.7498

90' SPREAD SETUP

ITEM NO.	PART NUMBER	DESCRIPTION	QTY.
1	4431277-L	SPINNER BLADE, 11 INCH, LH	6
2	4431277-R	SPINNER BLADE, 11 INCH, RH	6

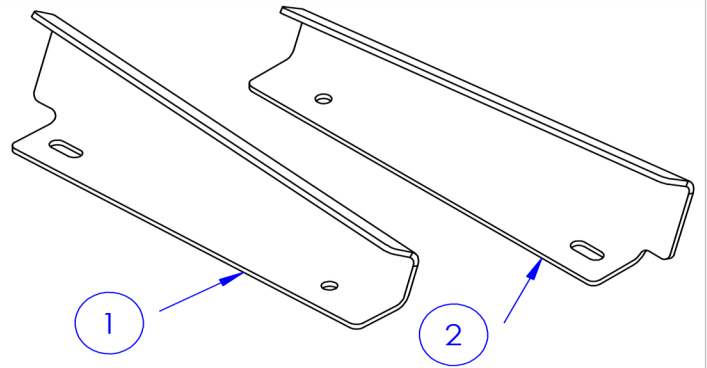

ALL BLADES SET TO 3RD HOLE FROM LEFT SIDE OF PATTERN, VIEWED FROM THE CENTER OF THE DISC

ALL BLADES SET TO 3RD HOLE FROM RIGHT SIDE OF PATTERN, VIEWED FROM THE CENTER OF THE DISC

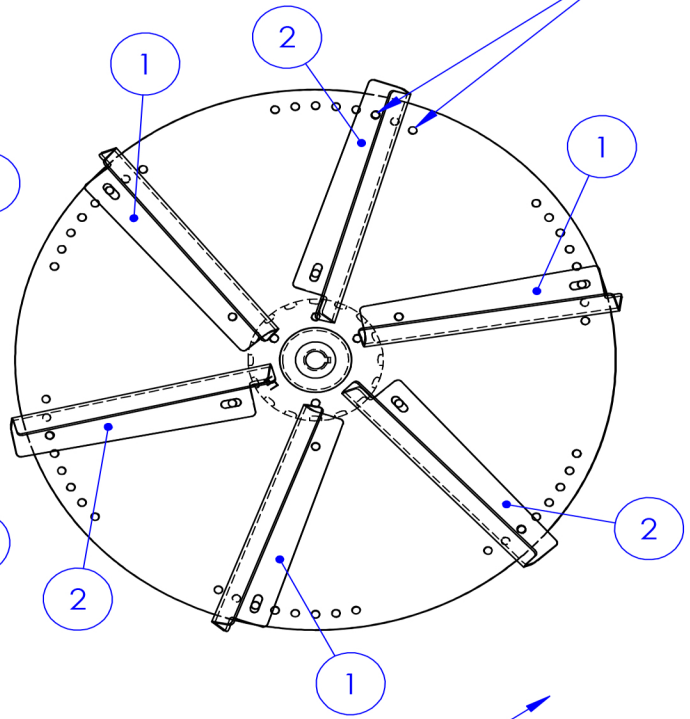
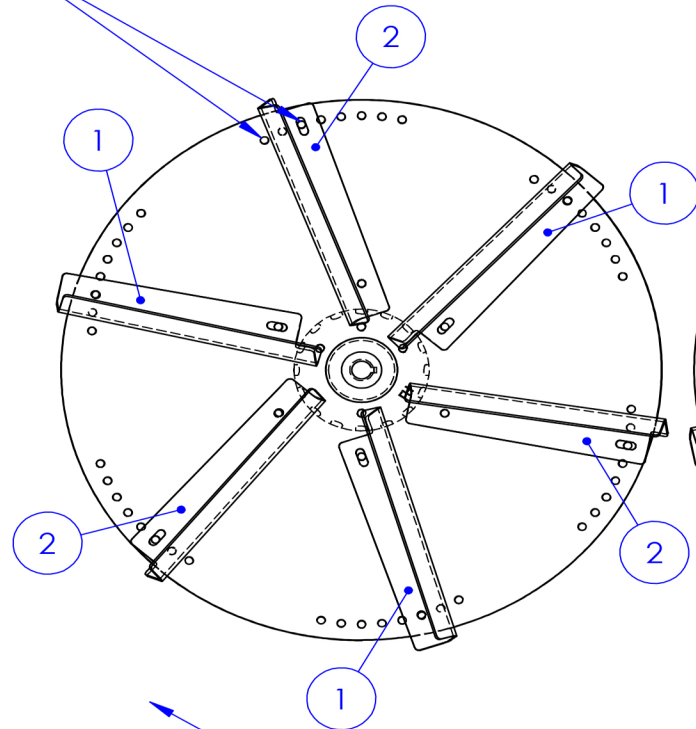

**4410815-L
COMPLETE SPINNER & BLADE SET (LEFT)**

**4410815-R
COMPLETE SPINNER & BLADE SET (RIGHT)**

VIEWED FROM BACK OF SPREADER

DRAWN BY	--	3/12/2021
CHECKED BY		
PRINT DATE	8/13/2024	
CONFIG.	90' SPREAD	



PROPRIETARY AND CONFIDENTIAL
THE INFORMATION CONTAINED IN THIS DRAWING IS THE SOLE PROPERTY OF DALTON AG. ANY REPRODUCTION IN PART OR AS A WHOLE WITHOUT THE WRITTEN PERMISSION OF DALTON AG IS PROHIBITED.

COMMENTS:

DWG: SPREAD SET UP, WIDE SPREAD

SIZE	SHEET TITLE:	REV
A	90' SPREAD	A
SCALE: 1:6	SHEET 1 OF 2	

FOR PARTS, CALL 1.800.342.7498

DISTRIBUTOR BLADE TUNING

FINE TUNING OF DISTRIBUTOR AND BLADE SETTINGS

All Mobility Spreaders are given an average standard factory setting of distributor blades. Such a setting, of course, cannot be perfect for all field conditions and materials. The following information will be helpful in adjusting the distributor blades on your machine to give optimum performance for your specific conditions.

Your spread pattern will be affected by 1) the material used, 2) the distributor blade setting, and 3) the rotation speed of the distributors. The distributors are designed to be operated at 750 RPM (540 tractor P.T.O. RPM). A plus or minus 10% change in distributor RPM will increase or decrease spread pattern width accordingly. An increase in PTO RPM will tend to deposit less material at the center of the spread pattern, while a decrease will deposit more material at the center. The physical characteristics of the materials being spread, which are important to the spread pattern, include bulk density, particle size, particle shape, physical strength and rugosity or surface roughness. For best performance it is recommended that you fine tune your machine to the material being used. The spreading profile and spread swath width can be changed drastically by alteration of the setting of the distributor blades. The drawing on the next page shows how blades may be extended from or retracted toward the center of the disc. Also, the angle of blade intersection with a radius of the disc may be altered. They may be advanced toward coincidence with the disc radius or retarded away from it. Further, blade lengths are not all equal. These adjustments affect the spread pattern in the following ways:

1. Advance long blades--more material to the outside of spread pattern; also will increase spread pattern width.
2. Retard long blades--opposite effect of above.
3. Advance short blades—helps eliminate problem of streaking in the middle of spread pattern.
4. Retard short blades—puts more material in the center of spread pattern.
5. Extend blades away from center of spinner—increases spread width somewhat.
6. Retract blades (more towards center of spinner)—opposite effect of above.
7. Moving flow divider (or chute) toward the front of spreader will tend to put more material in center of spread pattern. This is because material is deposited on outer edge of spinner causing it to leave earlier.
8. Moving divider toward the rear of the spreader has the opposite effect.

DISTRIBUTOR BLADE TUNING, WIDE SPREAD

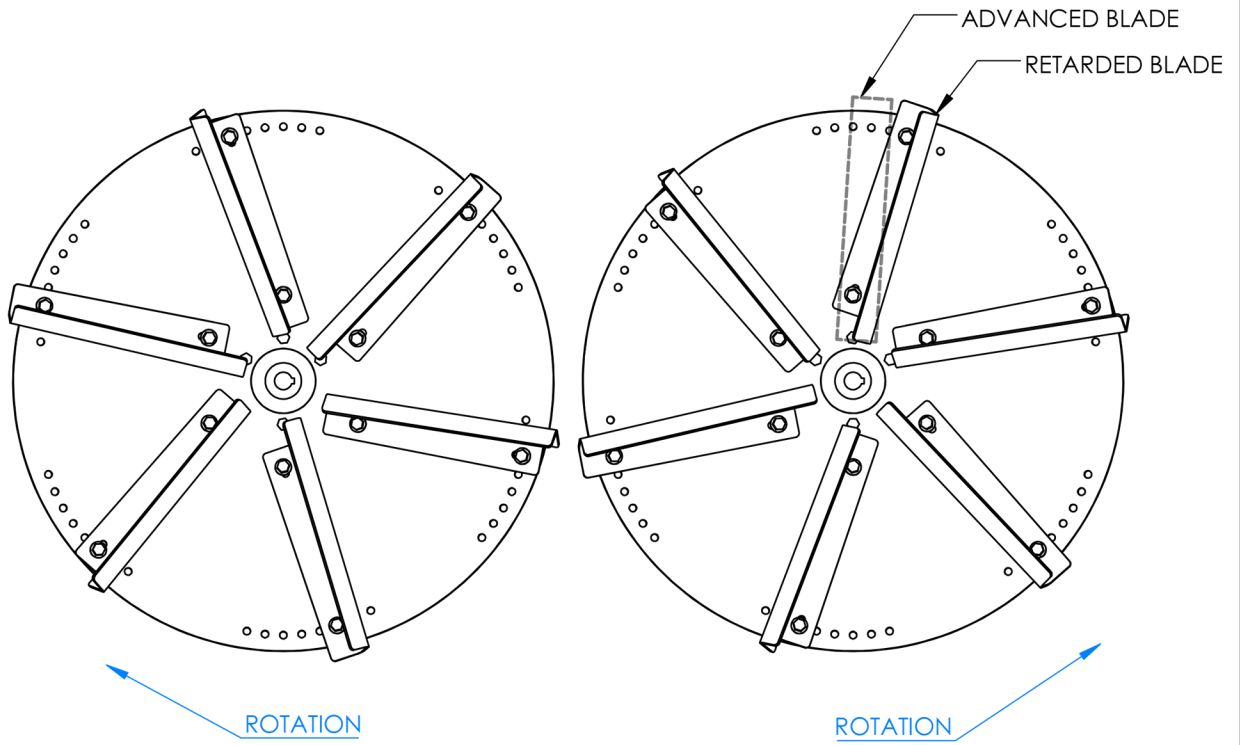

VIEWED FROM BACK OF SPREADER

DRAWN BY	RICH SMOTHERS	3/12/2021
CHECKED BY		
PRINT DATE	3/29/2021	
CONFIG.	90° SPREAD	
COMMENTS:		



PROPRIETARY AND CONFIDENTIAL
 THE INFORMATION CONTAINED IN THIS DRAWING IS THE SOLE PROPERTY OF DALTON AG. ANY REPRODUCTION IN PART OR AS A WHOLE WITHOUT THE WRITTEN PERMISSION OF DALTON AG IS PROHIBITED.

DWG: DISTRIBUTOR BLADE TUNING, WIDE SPREAD

SIZE	SHEET TITLE:	REV
A	Sheet1	A

FOR PARTS, CALL 1.800.342.7498

SCALE: 1:6 SHEET 1 OF 1

60' SPREAD

HYDRAULIC SPINNERS SET AT 750 RPM

LOW RANGE

12 to 72 T.

GATE OPENING	MATERIAL WEIGHT IN POUNDS PER CUBIC FOOT							
	40	45	50	55	60	65	70	75
1	37	42	46	51	55	60	64	69
1½	55	62	68	76	82	90	97	103
2	73	82	92	101	110	119	128	137
2½	92	103	114	126	137	149	160	172
3	110	124	137	152	165	179	192	207
3½	128	144	161	177	192	209	225	239
4	147	165	183	202	220	238	257	275
4½	165	186	207	227	247	268	289	309
5	183	207	229	252	275	298	321	344

HIGH RANGE

24 to 48 T.

GATE OPENING	MATERIAL WEIGHT IN POUNDS PER CUBIC FOOT							
	40	45	50	55	60	65	70	75
1	110	124	137	152	165	179	193	207
1½	165	186	207	227	247	269	290	310
2	220	247	275	302	330	358	387	413
2½	275	309	343	378	412	448	483	517
3	330	372	412	454	495	537	579	620
3½	385	433	481	529	577	627	676	723
4	440	495	550	605	660	717	772	827
4½	495	557	619	681	742	807	868	929
5	550	619	687	757	825	896	965	1033

APPLICATION RATE EXPRESSED IN POUNDS PER ACRE

BLADES MUST BE SET FOR SPREAD WIDTHDALTONAG.COM
1-800-342-7498**MOBILITY**
BY DALTON AG

PART NO.1001118-60

90' SPREAD

90' SPREAD

HYDRAULIC SPINNERS SET AT 750 RPM

LOW RANGE

12 to 72 T.

GATE OPENING	MATERIAL WEIGHT IN POUNDS PER CUBIC FOOT							
	40	45	50	55	60	65	70	75
1	25	28	31	34	37	40	43	46
1½	37	41	45	51	55	60	65	69
2	49	55	61	67	73	79	85	91
2½	61	69	76	84	91	99	107	115
3	73	83	91	101	110	119	128	138
3½	85	96	107	118	128	139	150	159
4	98	110	122	135	147	159	171	183
4½	110	124	138	151	165	179	193	206
5	122	138	153	168	183	199	214	229

HIGH RANGE

24 to 48 T.

GATE OPENING	MATERIAL WEIGHT IN POUNDS PER CUBIC FOOT							
	40	45	50	55	60	65	70	75
1	73	83	91	101	110	119	129	138
1½	110	124	338	151	165	179	193	207
2	147	165	183	201	220	239	258	275
2½	183	206	229	252	275	299	322	345
3	220	248	275	303	330	358	386	414
3½	257	289	321	353	385	418	451	482
4	293	330	367	404	440	478	515	552
4½	330	372	413	454	495	538	579	620
5	367	413	458	505	550	598	644	689

APPLICATION RATE EXPRESSED IN POUNDS PER ACRE

BLADES MUST BE SET FOR SPREAD WIDTH

DALTONAG.COM
1-800-342-7498

MOBILITY
BY DALTON AG

PART NO.1001118-90

60' to 90' SPREAD, VARIABLE RATE

60' - 90' SPREAD

HYDRAULIC SPINNERS SET AT 750 RPM

GATE OPENING	APPROXIMATE RATE
2	50 - 200
3	100 - 300
4	200 - 400
5	300 - UP

APPLICATION RATE EXPRESSED IN POUNDS PER ACRE

BLADES MUST BE SET FOR SPREAD WIDTH

MOBILITY
BY DALTON AG

DALTONAG.COM
1-800-342-7498

PART NO. 1001118-VR90

SPINNER PTO DRIVELINE

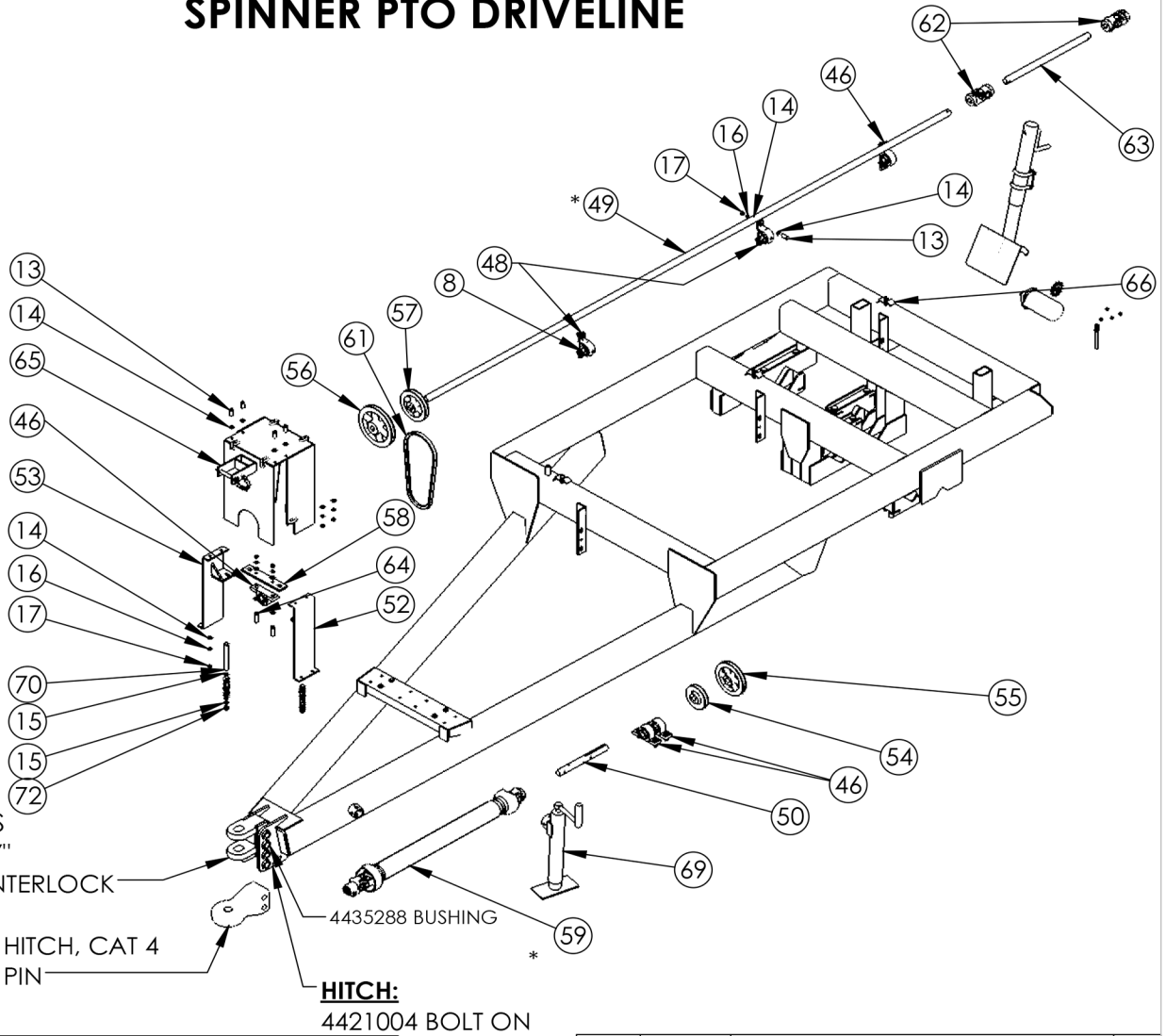

STANDARD:

- 4420532-HD CLEVIS
- 153002 BOLT, 1" X 7"
- 150061 NUT, 1" CENTERLOCK

OPTIONAL:

- 4440918 BULL PULL HITCH, CAT 4
- 4441048 BULL PULL PIN

HITCH:

4421004 BOLT ON

ITEM NO.	PART NUMBER	DESCRIPTION	QTY
8	150010	NUT, .625 NC, PLTD	8
13	151815	BOLT, .375 x 1.25 NC, SS	23
14	150214	FLAT WASHER, .375 SS	84
15	150214	FLAT WASHER, .375 SS	4
16	150248	LOCK WASHER, .375, SS	52
17	150046	NUT, .375 NC, SS	47
46	640511	BEARING, PILLOW BLOCK	4
48	1008456	1008456 SPLIT POLY BEARING & HOUSING	2
49	2001126	SHAFT, FRONT, 1X133, 8 TON	1
50	1004197	SHAFT	1
OR	4431385	SHAFT, FRONT, 1 X 134, WIDESPREAD	1
52	2001125	2001125 SHIELD, MOUNTING BRACKET WELDMNT, LH	1
53	2001124	2001124 SHIELD, MOUNTING BRACKET WELDMNT, RH	1
54	4440827	PULLEY, CAST IRON, 4.75" OD	1
55	4440830	PULLEY, CAST IRON, 6.75" OD	1
56	4440828	PULLEY, CAST IRON 8.25" OD	1

OR

ITEM NO.	PART NUMBER	DESCRIPTION	QTY
57	4440829	PULLEY, 6.25 DIA	1
58	2001052	BEARING ARM, FRONT	1
59	1009228	1009228 PTO COMPLETE, 540 12N	1
OR	4440853	PTO HALF, 1000 MALE 12N	1
61	1007099	B38 BELT	1
62	641667	641667 U-JOINT, DRIVE SHAFT	2
63	2001127	SHAFT, BACK, 1X21, 8 TON	1
64	151811	BOLT, .375 x 2 NC, G5, PLTD	2
65	4420418	RC 4420418 PTO SHIELD	2
66	4432539	HOSE CLIP	3
69	4440234	JACK, 5000# TALL, TOP WIND, PIPE MOUNT, SPREADER	1
70	1001885	BOLT, 7/16" x 6, GR 5, 7/16-14 X 6 CARR BOLT ZINC G5	2
72	158039	LOCK NUT, .4375	2

DRAWN BY	RICH SMOTHERS	1/15/2013
CHECKED BY		
PRINT DATE	8/12/2024	
CONFIG.	FRAME & DRIVELINE- 600-800 ROW CROP	
COMMENTS:		



PROPRIETARY AND CONFIDENTIAL
THE INFORMATION CONTAINED IN THIS DRAWING IS THE SOLE PROPERTY OF DALTON AG. ANY REPRODUCTION IN PART OR AS A WHOLE WITHOUT THE WRITTEN PERMISSION OF DALTON AG IS PROHIBITED.

DWG: FRAME & DRIVELINE- 600-800 ROW CROPS

SIZE **A** SHEET TITLE: 6 AND 8 TON ROW CROP REV **A**

FOR PARTS, CALL 1.800.342.7498

SCALE: 1:32 SHEET 1 OF 1

540 PTO

1009228 PTO COMPLETE, 540 12N

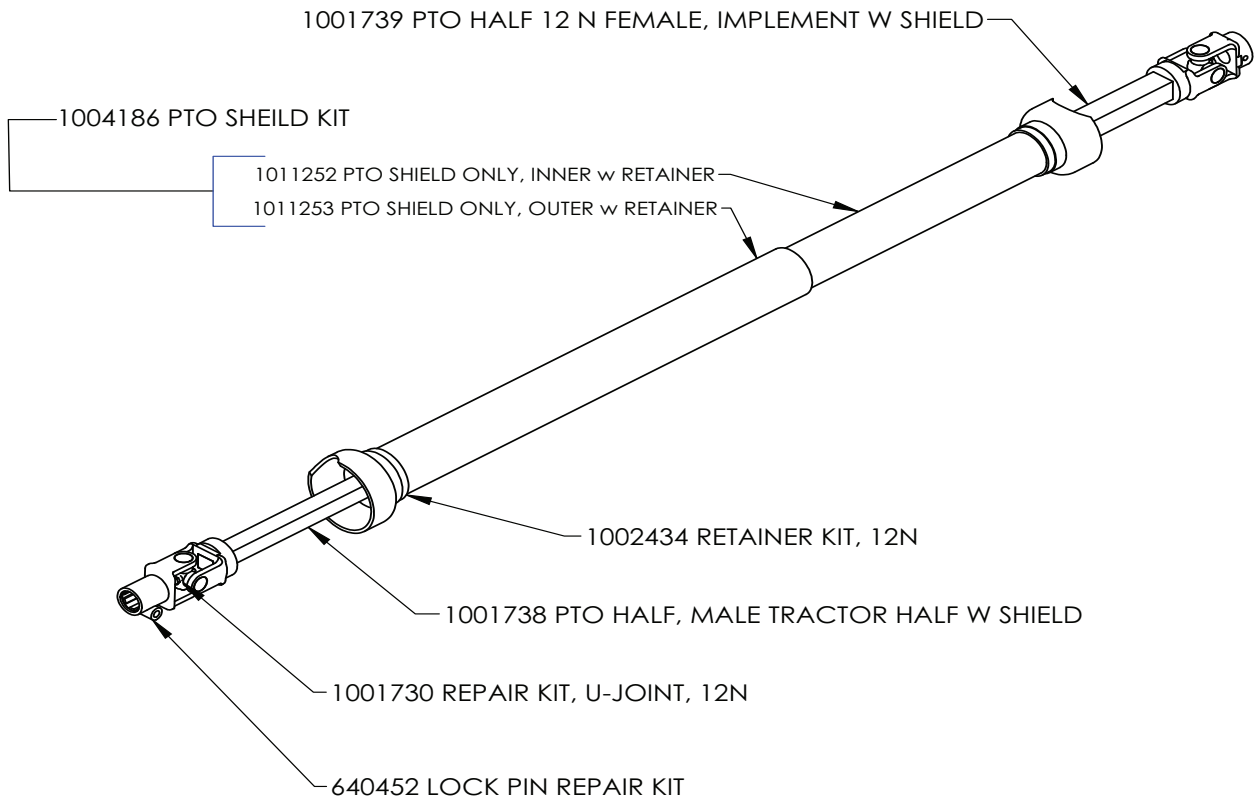

DRAWN BY	RICH SMOTHERS	7/7/2014
CHECKED BY		
PRINT DATE		7/28/2014
CONFIG.	Default	
COMMENTS:		



PROPRIETARY AND CONFIDENTIAL
THE INFORMATION CONTAINED IN THIS DRAWING IS THE SOLE PROPERTY OF DALTON AG. ANY REPRODUCTION IN PART OR AS A WHOLE WITHOUT THE WRITTEN PERMISSION OF DALTON AG IS PROHIBITED.

DWG: 1009228 540 RPM PTO SHAFT OPTION

SIZE	SHEET TITLE:	REV
A	Sheet1	A

FOR PARTS, CALL 1.800.342.7498

SCALE: 1:10

SHEET 1 OF 1

1000 PTO

4440854 1000 RPM PTO SHAFT

4440854 1000 RPM PTO SHAFT

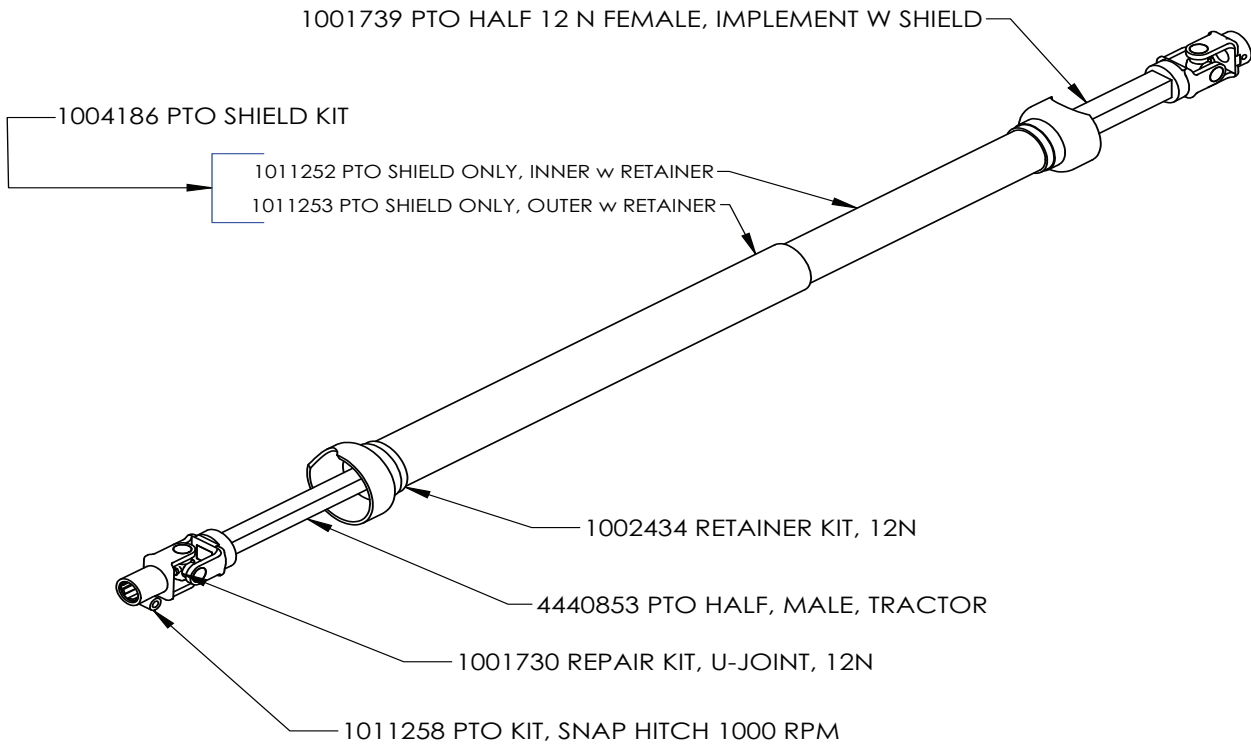

DRAWN BY	RICH SMOTHERS	7/7/2014
CHECKED BY		
PRINT DATE	12/24/2015	
CONFIG.	Default	



PROPRIETARY AND CONFIDENTIAL
 THE INFORMATION CONTAINED IN THIS DRAWING IS THE SOLE PROPERTY OF CMC-DALTON AG. ANY REPRODUCTION IN PART OR AS A WHOLE WITHOUT THE WRITTEN PERMISSION OF CMC-DALTON AG IS PROHIBITED.

COMMENTS:

DWG: 4440854 1000 RPM PTO SHAFT

SIZE A	SHEET TITLE: Sheet1	REV A
------------------	------------------------	-----------------

FOR PARTS, CALL 1.800.342.7498

SCALE: 1:10 SHEET 1 OF 1

6 TON ADJUSTABLE AXLE & HUB PARTS

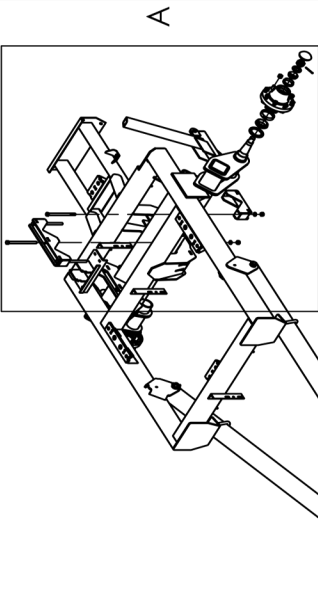

**NOTE: CENTER CLAMP
REQUIRES 9.5" BOLTS**

ADJUSTABLE AXLE CLAMP, CENTER,
WELDMENT 2001044

**NOTE: OUTER CLAMPS
REQUIRE 9.0" BOLTS**

158328 BOLT, 5/8-11 X 9.0, GR 5, ZINC PLATED

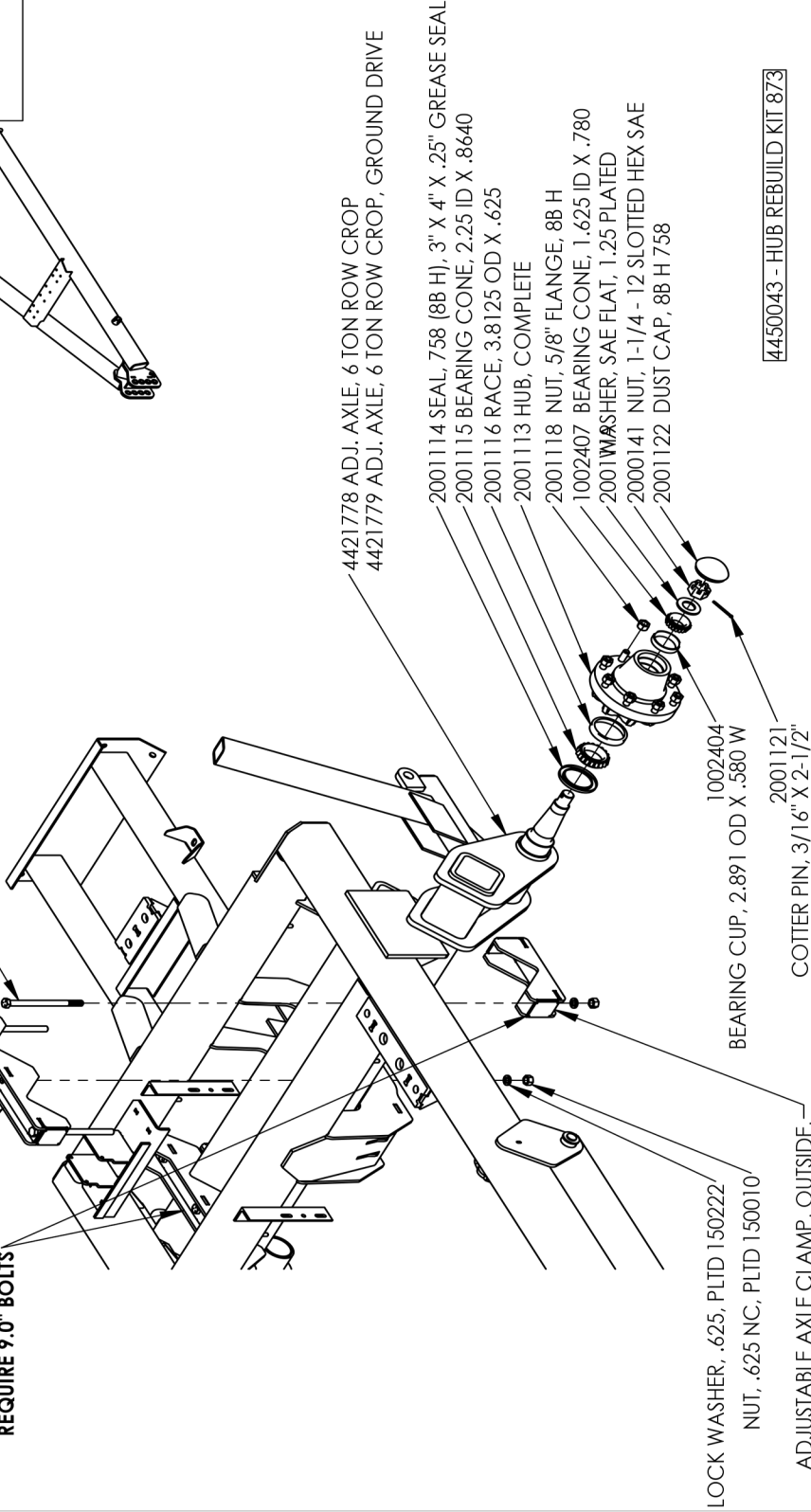

4421778 ADJ. AXLE, 6 TON ROW CROP
4421779 ADJ. AXLE, 6 TON ROW CROP, GROUND DRIVE

2001114 SEAL, 758 (88 H), 3" X 4" X .25" GREASE SEAL

2001115 BEARING CONE, 2.25 ID X .8640

2001116 RACE, 3.8125 OD X .625

2001113 HUB, COMPLETE

2001118 NUT, 5/8" FLANGE, 88 H

1002407 BEARING CONE, 1.625 ID X .780

2001117 WASHER, SAE FLAT, 1.25 PLATED

2000141 NUT, 1-1/4 - 12 SLOTTED HEX SAE

2001122 DUST CAP, 88 H 758

LOCK WASHER, .625, PLTD 150222
NUT, .625 NC, PLTD 150010

ADJUSTABLE AXLE CLAMP, OUTSIDE,
WELDMENT 2001045

1002404
BEARING CUP, 2.891 OD X .580 W

2001121
COTTER PIN, 3/16" X 2-1/2"

4450043 - HUB REBUILD KIT 873

DRAWN BY Jeremiah Jondle 4/19/2024

CHECKED BY 8/12/2024

PRINT DATE

CONFIG. Default

COMMENTS:



DWG: 6 TON ADJUSTABLE AXLE & HUB PARTS - BMLC

SIZE	SHEET TITLE:	REV
A	Sheet1	B

SCALE: 1:64 SHEET 1 OF 1

PROPRIETARY AND CONFIDENTIAL
THE INFORMATION CONTAINED IN THIS DRAWING IS THE SOLE PROPERTY OF DALTON AG. ANY REPRODUCTION IN PART OR AS A WHOLE WITHOUT THE WRITTEN PERMISSION OF DALTON AG IS PROHIBITED.

C:_EPDM_Vault\Spreader\MOBILITY\MS Assemblies\

5 4 3 2 1

8 TON ADJUSTABLE AXLE & HUB PARTS

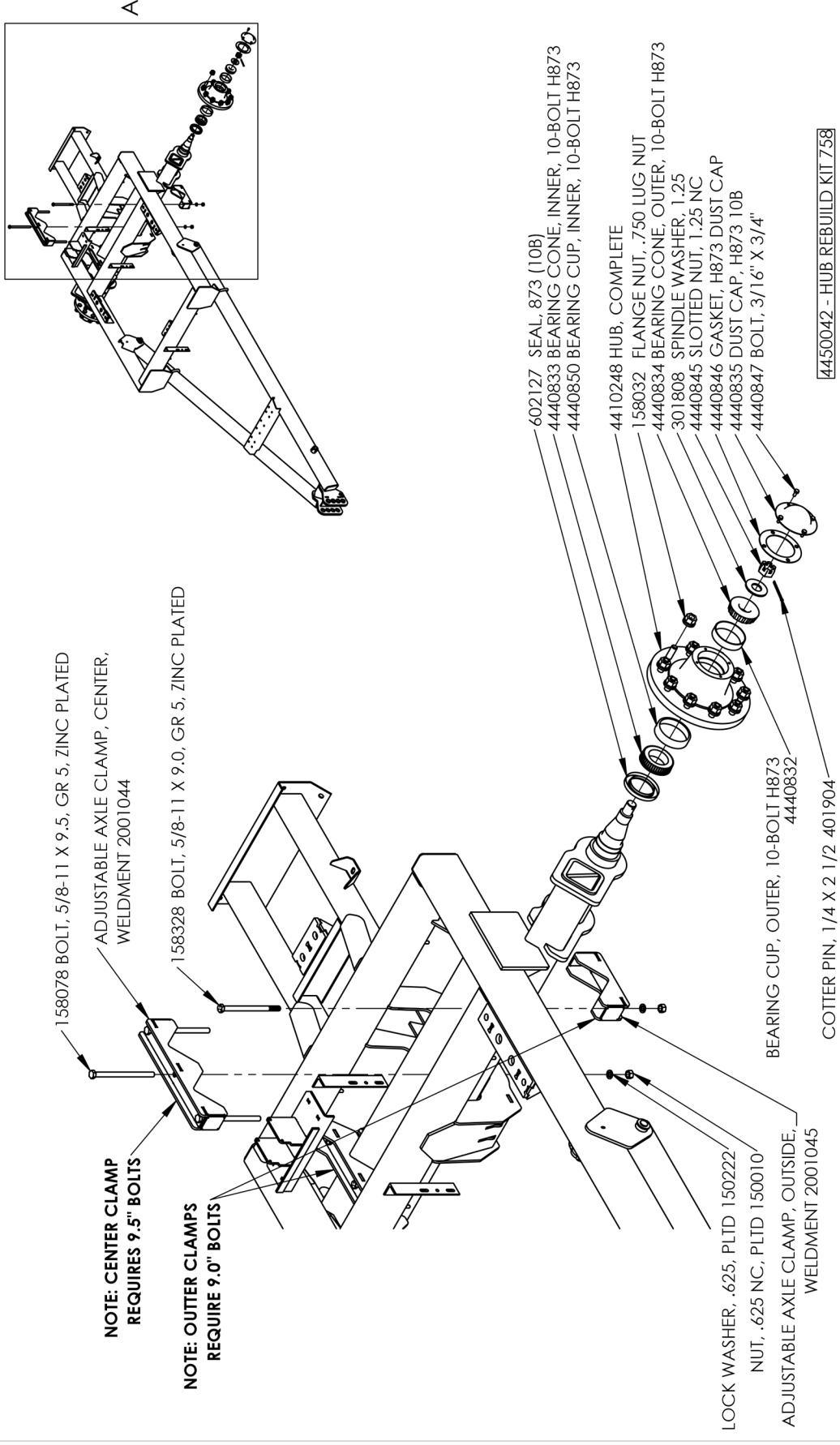

DRAWN BY	Jeremiah Jonale	4/19/2024		
CHECKED BY				
PRINT DATE	4/22/2024			
CONFIG.	Default			
COMMENTS:				
DWG:		8 TON ADJUSTABLE AXLE & HUB PARTS - BMLC		
SIZE	A	SHEET TITLE:	Sheet1	REV
SCALE:	1:64			A
				SHEET 1 OF 1

PROPRIETARY AND CONFIDENTIAL
THE INFORMATION CONTAINED IN THIS DRAWING IS THE SOLE PROPERTY OF DALTON AG. ANY REPRODUCTION IN PART OR AS A WHOLE WITHOUT THE WRITTEN PERMISSION OF DALTON AG IS PROHIBITED.

C:_EPDM_Vault\Spreader\MOBILITY\MS Assemblies\

10 & 12 TON ADJUSTABLE AXLE & HUB PARTS

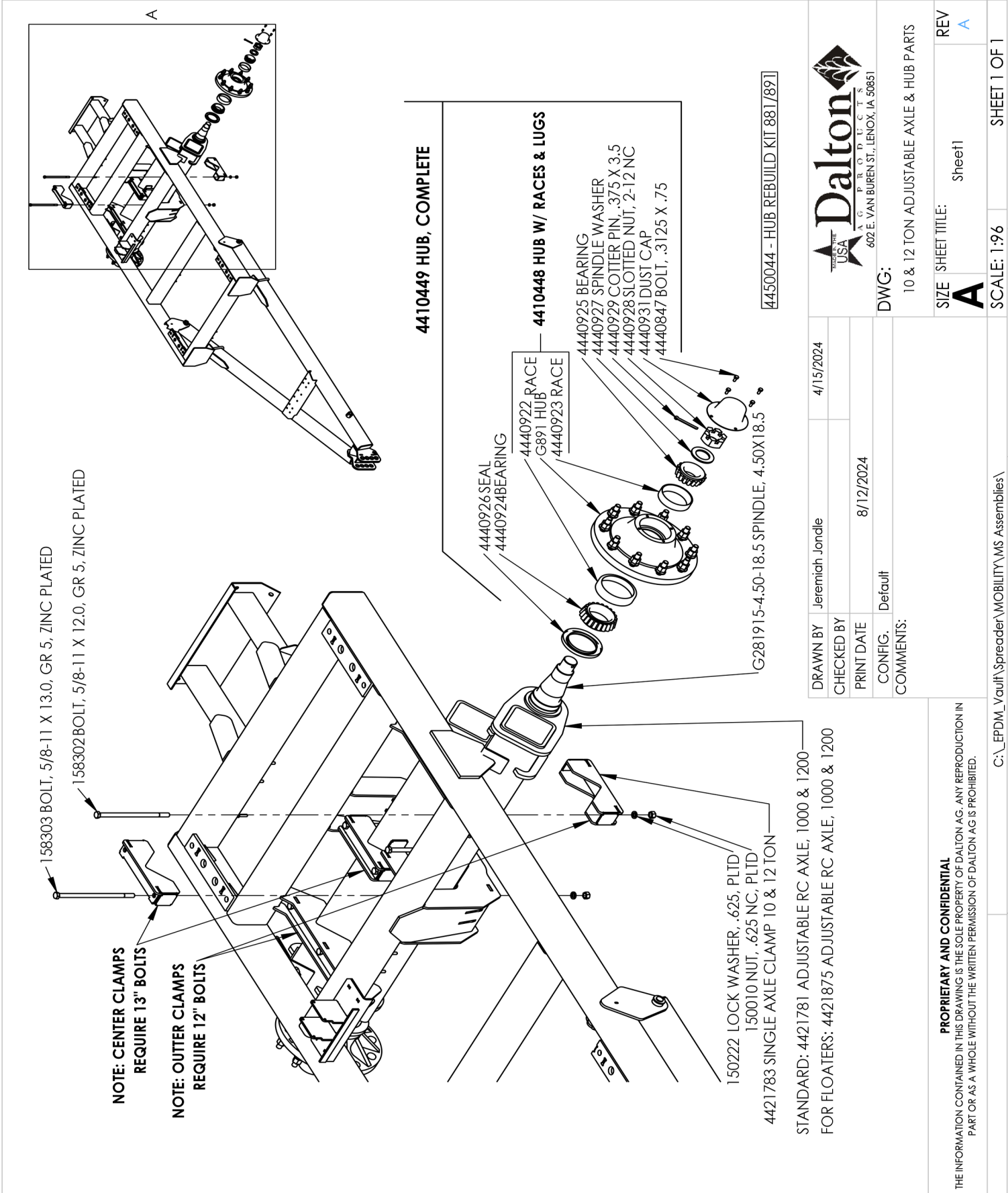

PROPRIETARY AND CONFIDENTIAL
 THE INFORMATION CONTAINED IN THIS DRAWING IS THE SOLE PROPERTY OF DALTON AG. ANY REPRODUCTION IN PART OR AS A WHOLE WITHOUT THE WRITTEN PERMISSION OF DALTON AG IS PROHIBITED.

GROUND DRIVE ASSEMBLY

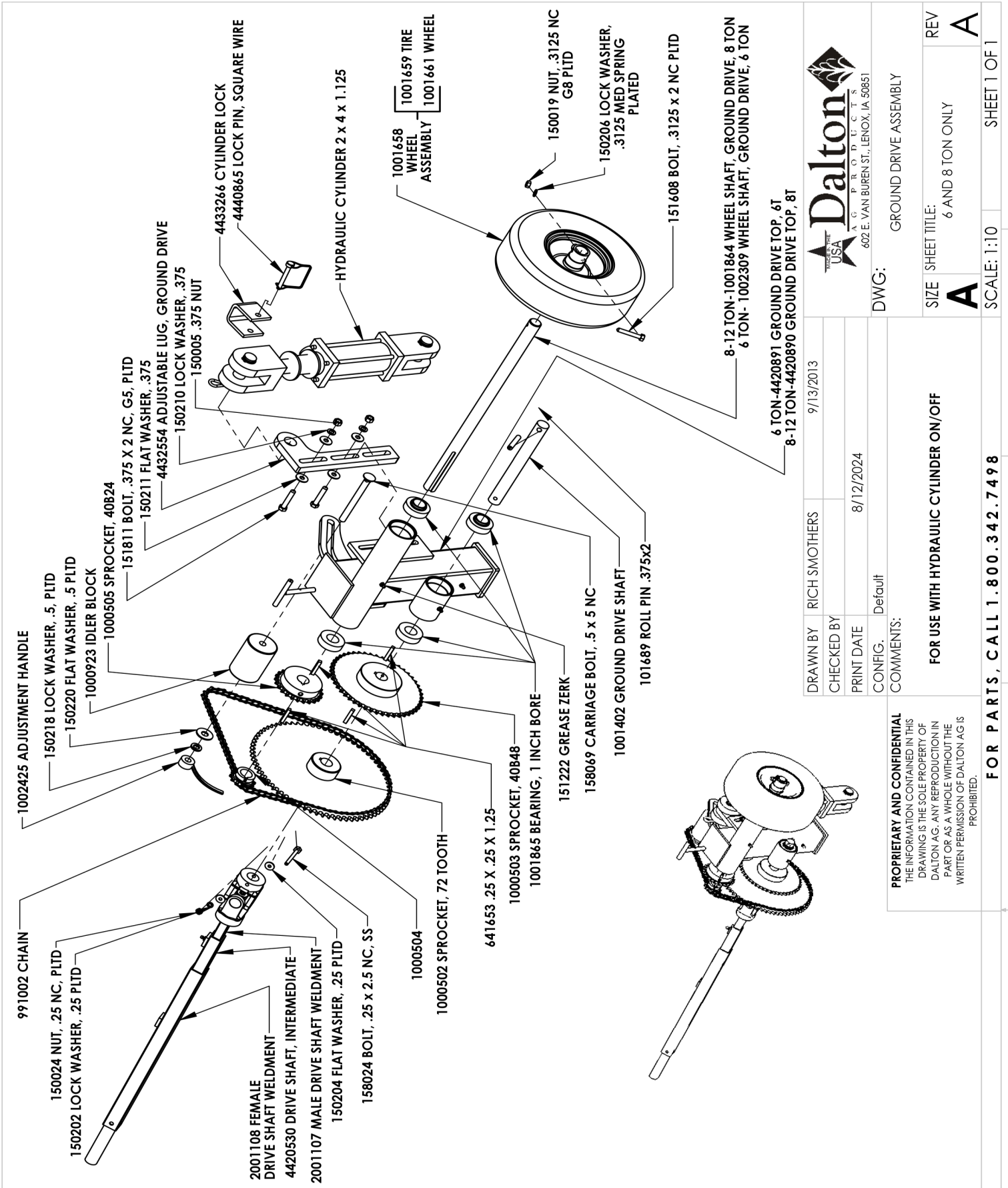

DRAWN BY RICH SMOTHERS 9/13/2013
 CHECKED BY
 PRINT DATE 8/12/2024
 CONFIG. Default
 COMMENTS:

DWG: GROUND DRIVE ASSEMBLY
 SIZE SHEET TITLE: A 6 AND 8 TON ONLY REV A
 SCALE: 1:10 SHEET 1 OF 1

PROPRIETARY AND CONFIDENTIAL
 THE INFORMATION CONTAINED IN THIS DRAWING IS THE SOLE PROPERTY OF DALTON AG. ANY REPRODUCTION IN PART OR AS A WHOLE WITHOUT THE WRITTEN PERMISSION OF DALTON AG IS PROHIBITED.

FOR USE WITH HYDRAULIC CYLINDER ON/OFF

FOR PARTS, CALL 1.800.342.7498

BOLT ON GROUND DRIVE MOUNT, ROW CROP

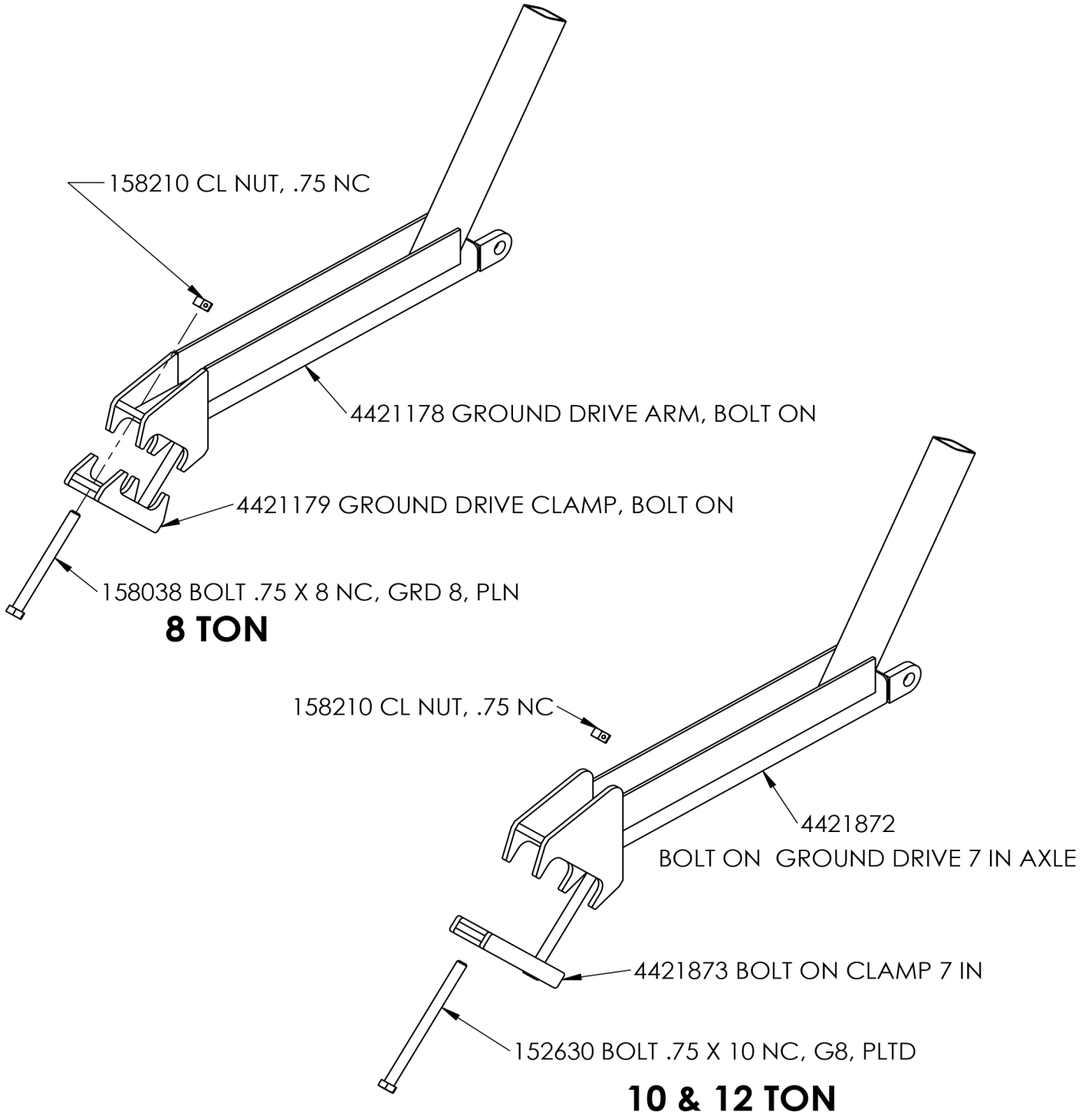

DRAWN BY	--	1/17/2024
CHECKED BY		
PRINT DATE		8/12/2024
CONFIG.	Default	
COMMENTS:		



PROPRIETARY AND CONFIDENTIAL
 THE INFORMATION CONTAINED IN THIS DRAWING IS THE SOLE PROPERTY OF DALTON AG. ANY REPRODUCTION IN PART OR AS A WHOLE WITHOUT THE WRITTEN PERMISSION OF DALTON AG IS PROHIBITED.

DWG: BOLT ON GROUND DRIVE, ROW CROP

SIZE	SHEET TITLE:	REV
A	Sheet1	A

FOR PARTS, CALL 1.800.342.7498

SCALE: 1:16 SHEET 1 OF 1

FRONT TANK ASSEMBLY

4440882 ROLL TARP, 93 X 120, MOBILITY 6 & 8 TON
 4441752 ROLL TARP 102 X 152 BMLC 10 & 12 TON
 *BMLC-BOX MOUNTED LOAD CELLS

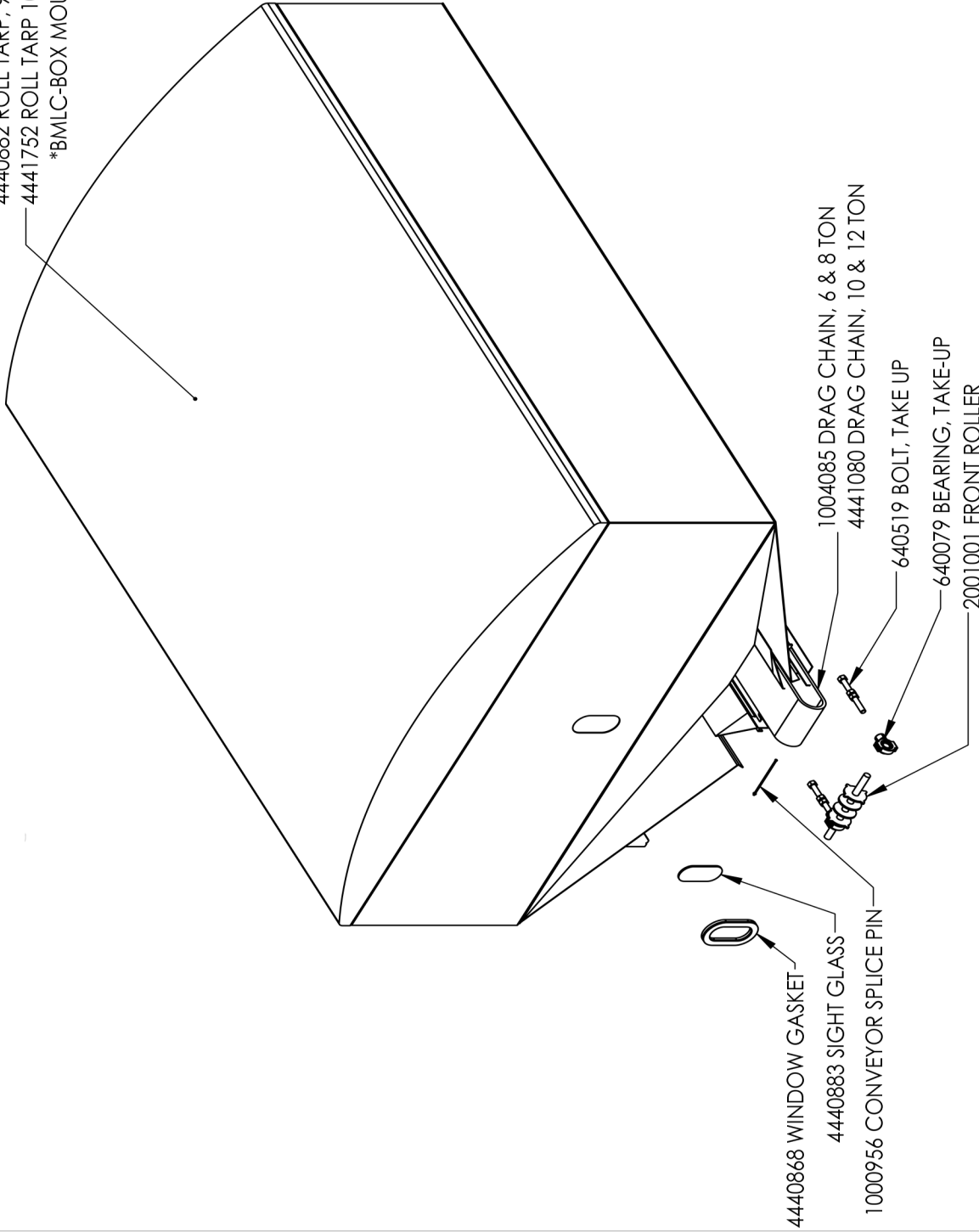

5/2/2017

DRAWN BY

CHECKED BY

PRINT DATE

8/12/2024

CONFIG.

FRONT TANK ASSEMBLY, ROW CROP

COMMENTS:

DWG:

FRONT TANK ASSEMBLY, ROW CROP



PROPRIETARY AND CONFIDENTIAL

THE INFORMATION CONTAINED IN THIS DRAWING IS THE SOLE PROPERTY OF DALTON AG. ANY REPRODUCTION IN PART OR AS A WHOLE WITHOUT THE WRITTEN PERMISSION OF DALTON AG IS PROHIBITED.

SIZE SHEET TITLE:

A 6, 8 AND 10 TON

REV

A

SCALE: 1:24

SHEET 1 OF 1

5

4

3

2

1

C:_EPDM_Vault\Spreader\MOBILITY\MS Assemblies\

GATE JACK ASSEMBLY

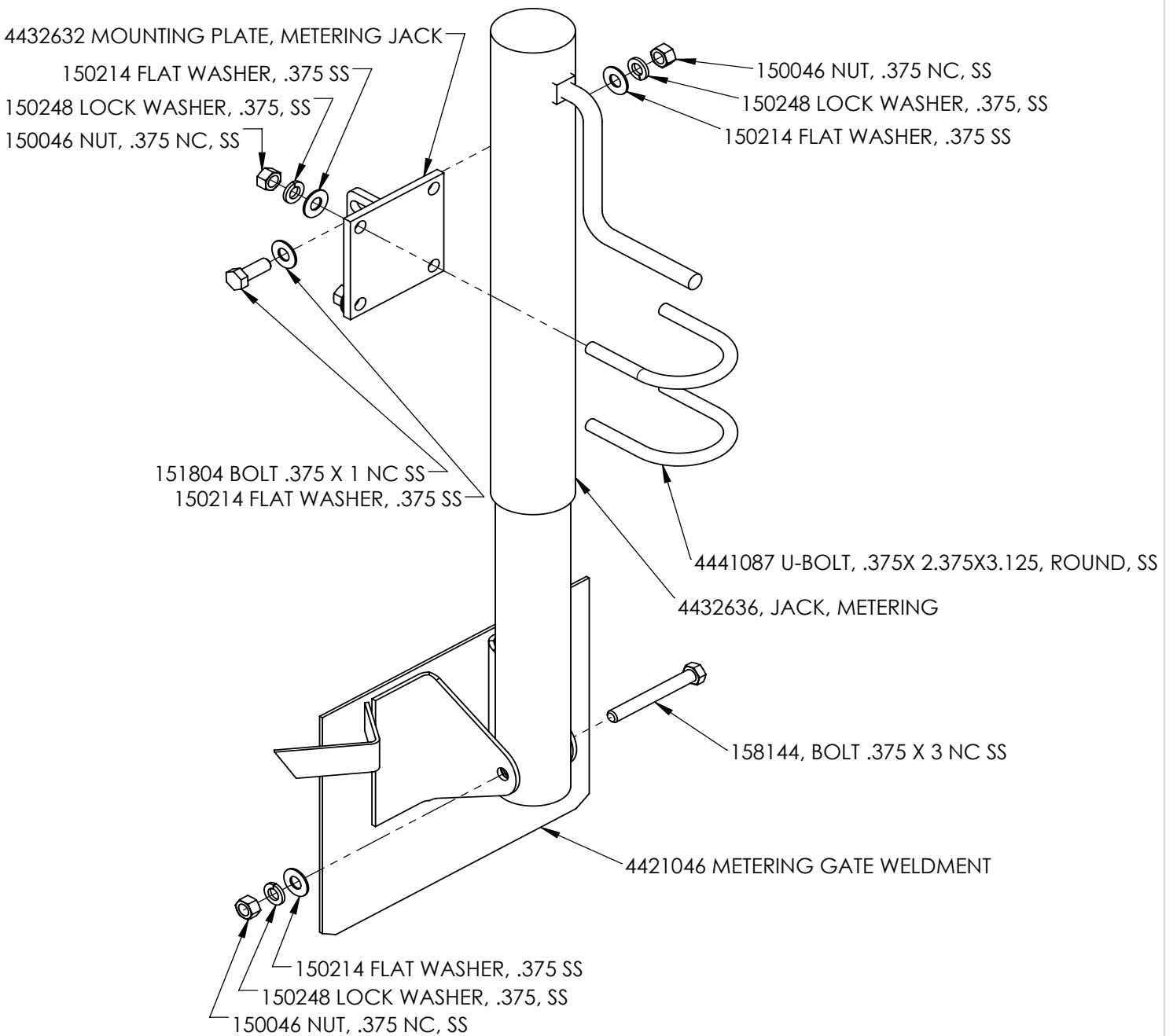

DRAWN BY	RICH SMOTHERS	3/30/2017
CHECKED BY		
PRINT DATE	1/16/2024	
CONFIG.	Default	



PROPRIETARY AND CONFIDENTIAL
 THE INFORMATION CONTAINED IN THIS DRAWING IS THE SOLE PROPERTY OF DALTON AG. ANY REPRODUCTION IN PART OR AS A WHOLE WITHOUT THE WRITTEN PERMISSION OF DALTON AG IS PROHIBITED.

COMMENTS:

DWG: GATE JACK ASSEMBLY

SIZE	SHEET TITLE:	REV
A	Sheet1	A

FOR PARTS, CALL 1.800.342.7498

SCALE: 1:4 SHEET 1 OF 1

REAR AREA ASSEMBLY

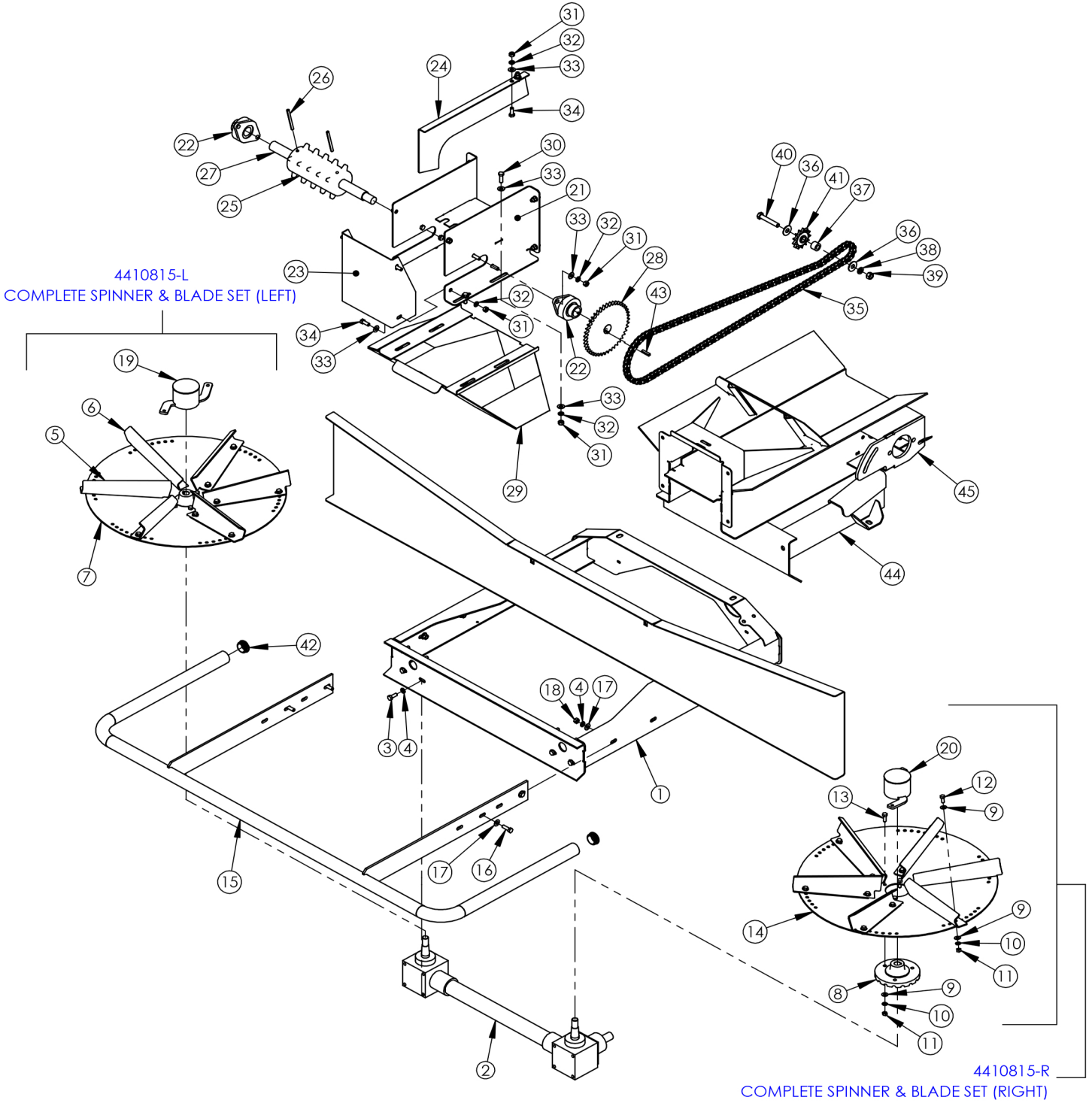

4410815-L
COMPLETE SPINNER & BLADE SET (LEFT)

4410815-R
COMPLETE SPINNER & BLADE SET (RIGHT)

DRAWN BY	--	2/2/2024
CHECKED BY		
PRINT DATE	8/13/2024	
CONFIG.	Default	
COMMENTS:		



PROPRIETARY AND CONFIDENTIAL
THE INFORMATION CONTAINED IN THIS DRAWING IS THE SOLE PROPERTY OF DALTON AG. ANY REPRODUCTION IN PART OR AS A WHOLE WITHOUT THE WRITTEN PERMISSION OF DALTON AG IS PROHIBITED.

DWG: REAR AREA ASSEMBLY, BMLC WS

SIZE	SHEET TITLE:	REV
A	Sheet1	A
SCALE: 1:64	SHEET 1 OF 2	

FOR PARTS, CALL 1.800.342.7498

REAR AREA ASSEMBLY

ITEM NO.	PART NUMBER	DESCRIPTION	QTY.
1	4421811	REAR SECTION, A FRAME, 90' SPREAD, BOLT ON	1
2	4441174	GEAR BOX SET, 26.375" CENTERLINE OUTPUT	1
3	151804	BOLT .375 X 1 NC SS	8
4	150248	LOCK WASHER, .375, SS	12
5	4431277	SPINNER BLADE, 11 INCH, LH	3
6	4431277	SPINNER BLADE, 11 INCH, RH	3
7	4432820L	DISTRIBUTOR DISC, FORMED LH	1
8	1003709	SPINNER HUB	1
9	158054	FLAT WASHER, .3125, SS	28
10	158053	LOCK WASHER, .3125 SS	16
11	150007	NUT, .3125 NC, SS	16
12	151615	BOLT, .3125 X .75 SS	12
13	151610	.3125 X 1 NC SS	4
14	4432820R	SPINNER PLATE	1
15	4421647	4420577-80 REAR BUMPER, RC SPREADER	1
16	151815	BOLT, .375 X 1.25 NC, SS	4
17	150214	FLAT WASHER, .375 SS	8
18	150046	NUT, .375 NC, SS	4
19	4421685	DISC CAP WELDMENT L.H.	1
20	4421686	DISC CAP WELDMENT R.H.	1
21	4421816	REAR EXTENSION, 90' SPREAD	1
22	1000646	BEARING, FLANGE HOUSED 1-1/4" ID	2
23	1001390	TROUGH EXTENSION BACK	1
24	4432469	PARTER PLATE, WIDE SPREAD	1
25	1000684	1000684 CAST SPROCKET, MACHINED	1
26	158035	ROLL PIN .3125 X 3.5	2
27	4432598	REAR ROLLER SHAFT	1
28	1000507	SPROCKET, 50B36	1
29	4421684	DIVIDER, WELDMENT, WIDE SPREAD, DISCHARGE	1
30	151815	BOLT, .375 X 1.25 NC, SS	8
31	150046	NUT, .375 NC, SS	17
32	150248	LOCK WASHER, .375, SS	18
33	150214	FLAT WASHER, .375 SS	18
34	151804	BOLT .375 X 1 NC SS	10
35	991003	CHAIN #50 SS	1
36	150220	FLAT WASHER, .5 PLTD	2
37	955113-.75	BUSHING	1
38	150218	LOCK WASHER, .5 PLTD	1
39	150008	NUT, .5 NC, GR 5, PLTD	1
40	152224	BOLT .5 X 3 NC, G5	1
41	140058	SPROCKET, 50B-13, .5 BORE. IDLER	1
42	4441075	1.25 PIPE CAP	2
43	641653	KEY 1/4" X 1/4" X 1-1/4"	1
44		FRAME WELDMENT, REAR PORTION, BMLC	1
45		BOX WELDMENT, REAR PORTION, BMLC	1

DRAWN BY	RICH SMOTHERS	2/2/2024
CHECKED BY		
PRINT DATE		8/13/2024
CONFIG.	Default	



PROPRIETARY AND CONFIDENTIAL
 THE INFORMATION CONTAINED IN THIS DRAWING IS THE SOLE PROPERTY OF DALTON AG. ANY REPRODUCTION IN PART OR AS A WHOLE WITHOUT THE WRITTEN PERMISSION OF DALTON AG IS PROHIBITED.

COMMENTS:

DWG:	REAR AREA ASSEMBLY, BMLC WS	
SIZE	SHEET TITLE:	REV
A	Sheet2	A

FOR PARTS, CALL 1.800.342.7498

SCALE: 1:64 SHEET 2 OF 2

4441174, GEAR BOX SET

ITEM	PART #	DESCRIPTION	QTY
1	1003735	BOX ASSEMBLY, RH	1
2	1000938	PLUG, SOFT	2
3	1000932	BEARING	8
4	1002426	GEAR	2
5	1000936	HOUSING, RH	1
6	1006856	OIL PLUG	2
7	1000935	KEY, WOODRUFF	2
8	1003730	SHAFT, TAPERED	1
9	1000933	RETAINER RING	5
10	1000931	RETAINER RING	8
11	1000930	SEAL	3
12	4441653	TUBE ASSEMBLY	1
13	1000944	HOUSING BARREL	3
14	4441654	CONNECTING TUBE	1
15	4441655	CONNECTING SHAFT	1
16	1000945	PINION GEAR	2
17	1003736	BOX ASSEMBLY, LH	1
18	1003730	SHAFT, TAPERED	1
19	1000947	HOUSING, LH	1
20	1001205	BARREL ASSEMBLY	1
21	1000948	SHAFT & GEAR ASSEMBLY	1
22	1000940	GASKET	3
23	1000834	HHCS, 5/16-18 x 3/4"	12
24	1000836	LOCK WASHER, 5/16"	12
25	1003742	45 DEGREE GREASE ZERK	2

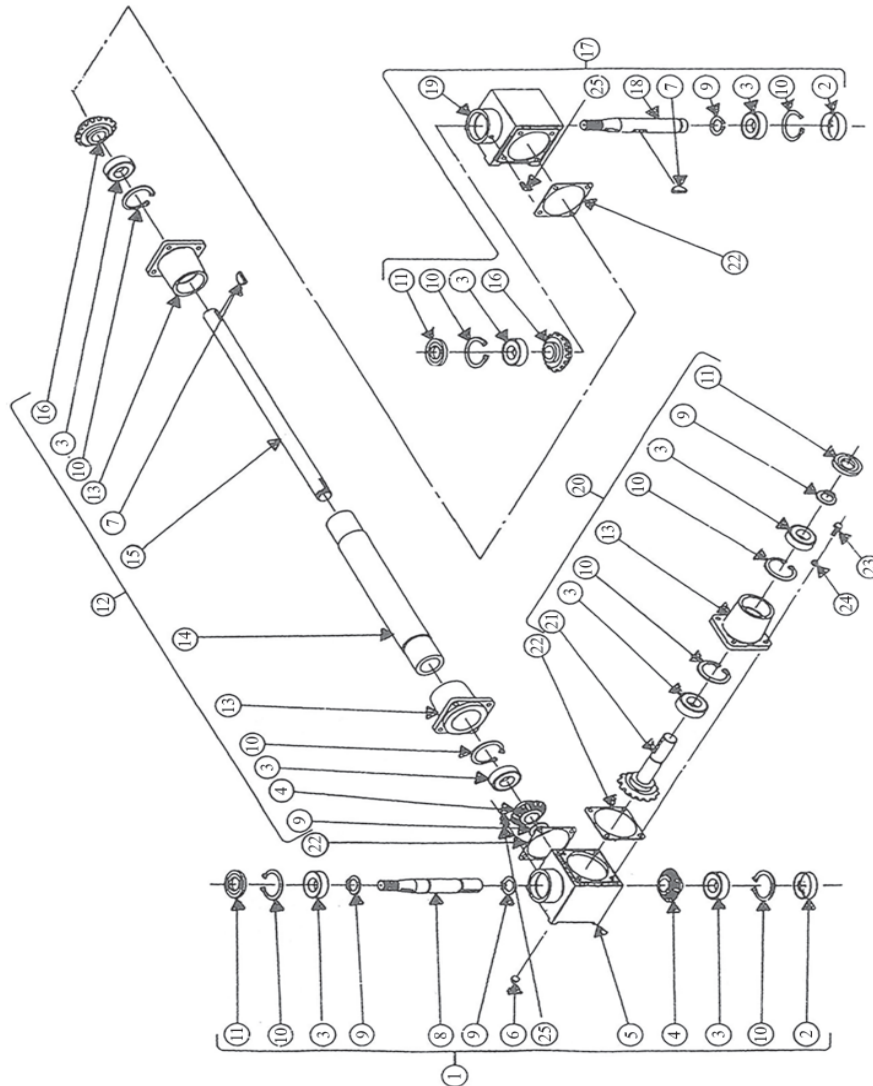

ROW CROP HYDRAULIC SPINNERS, WIDE SPREAD

ROW CROP HYD. SPINNERS, WIDE SPREAD

4441175 SPINNER MOTOR, PARKER, 340 TLBS OF TORQUE AT 8 GPM

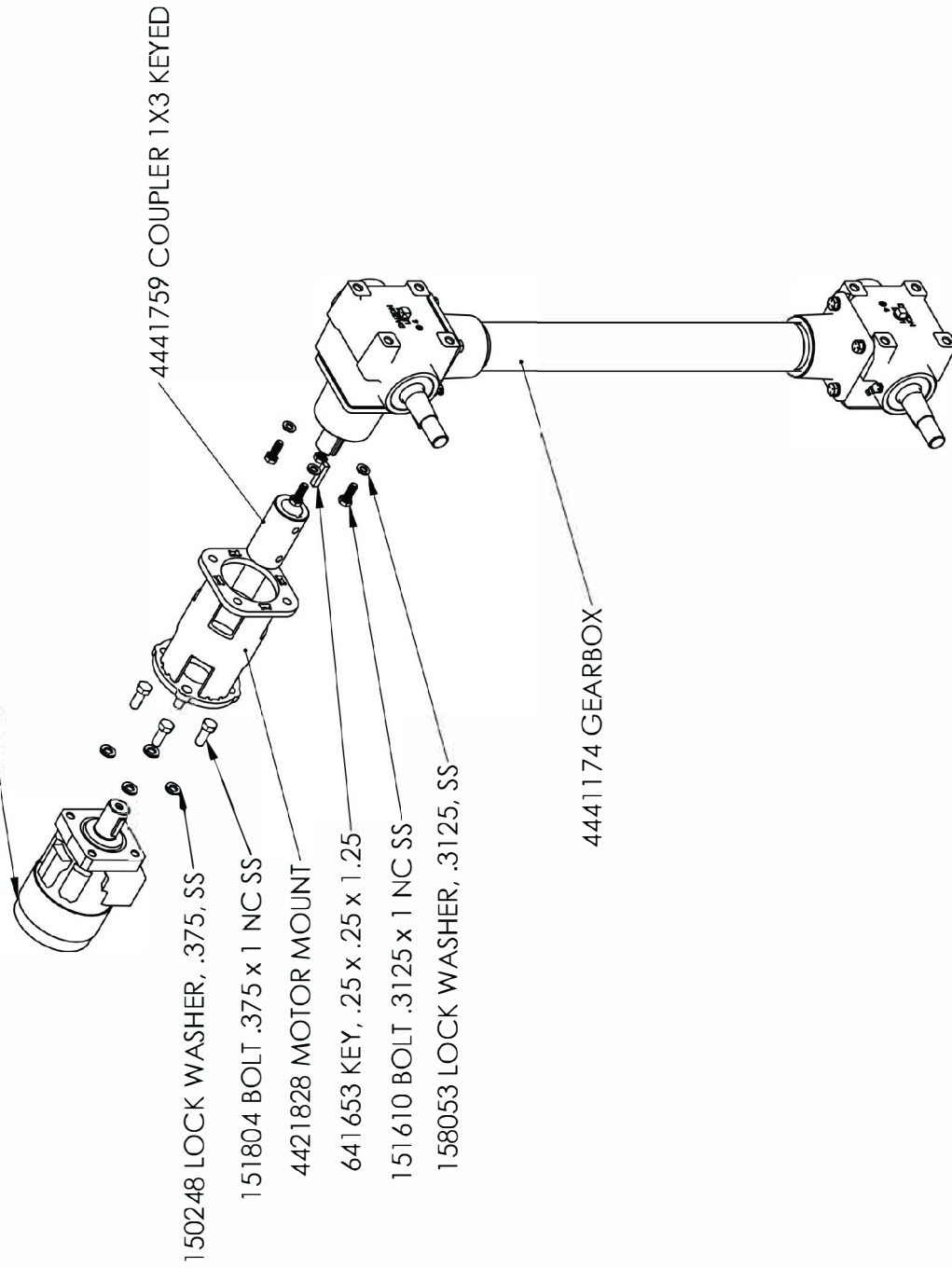

UNLESS OTHERWISE SPECIFIED TOLERANCES TO BE: ANGLES: ±1.0° FRACTIONS <6": ±1/32, >6"-1/16 X.X: ±0.06 X.XX: ±0.03 X.XXX: ±0.005		DRAWN BY: David Buchanan	11/12/2020
CHECKED BY:		PRINT DATE: 4/1/2024	
CONFIG: Default		COMMENTS:	
ROW CROP HYD. SPINNERS, WIDE SPREAD			
DWG: ROW CROP HYD. SPINNERS, WIDE SPREAD			
SIZE: A	SHEET TITLE: Sheet1	SCALE: 1:12	SHEET 1 OF 1
REV:			
C:\SOLIDWORKS Data\EPDM_Vault\Spreader\MOBILITY\MS Documents\MS MANUALS\90 FOOT SPREADER MANUAL\		3	2
PROPRIETARY AND CONFIDENTIAL THE INFORMATION CONTAINED IN THIS DRAWING IS THE SOLE PROPERTY OF DALTON AG. ANY REPRODUCTION IN PART OR AS A WHOLE WITHOUT THE WRITTEN PERMISSION OF DALTON AG IS PROHIBITED.		4	5

TRACTOR HYDRAULIC DRIVEN SPINNERS, HYDRAULIC BLOCK

TRACTOR HYDRAULIC DRIVEN SPINNERS, WIDE SPREAD

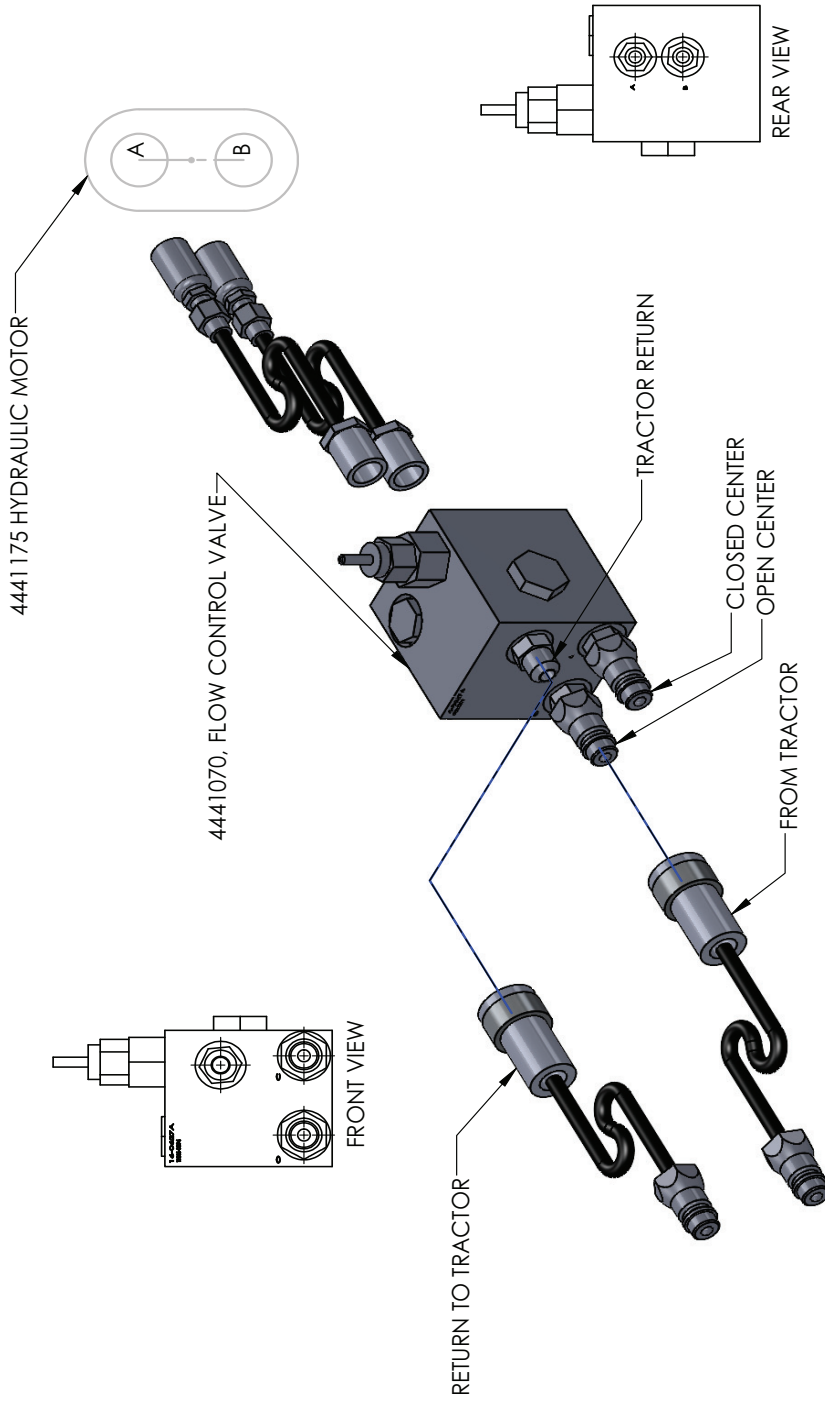

FACTORY SET TO 750 RPM

DRAWN BY	Llong	3/31/2017		
CHECKED BY				
PRINT DATE	5/10/2021			
CONFIG:	Default			
COMMENTS:				
PROPRIETARY AND CONFIDENTIAL THE INFORMATION CONTAINED IN THIS DRAWING IS THE SOLE PROPERTY OF DALTON AG. ANY REPRODUCTION IN PART OR AS A WHOLE WITHOUT THE WRITTEN PERMISSION OF DALTON AG IS PROHIBITED.		C:_epdm_vault\spreader\mobility\ms documents\ms manuals\yc 600 & 800\		
DWG:	602 E. VAN BUREN ST., LENOX, IA 50851			
TRACTOR HYDRAULIC DRIVEN SPINNERS, WIDE SPREAD		SIZE	SHEET TITLE:	REV
		A	SCHEMATIC	
		SCALE: 1:4	SHEET 1 OF 1	

MOBILITY HYDRAULIC DRIVEN SPINNERS, PWM VALVE

PURCHASE
Material <not specified>

MOBILITY HYDRAULIC SPINNER DRIVE LAYOUT, WIDE SPREAD

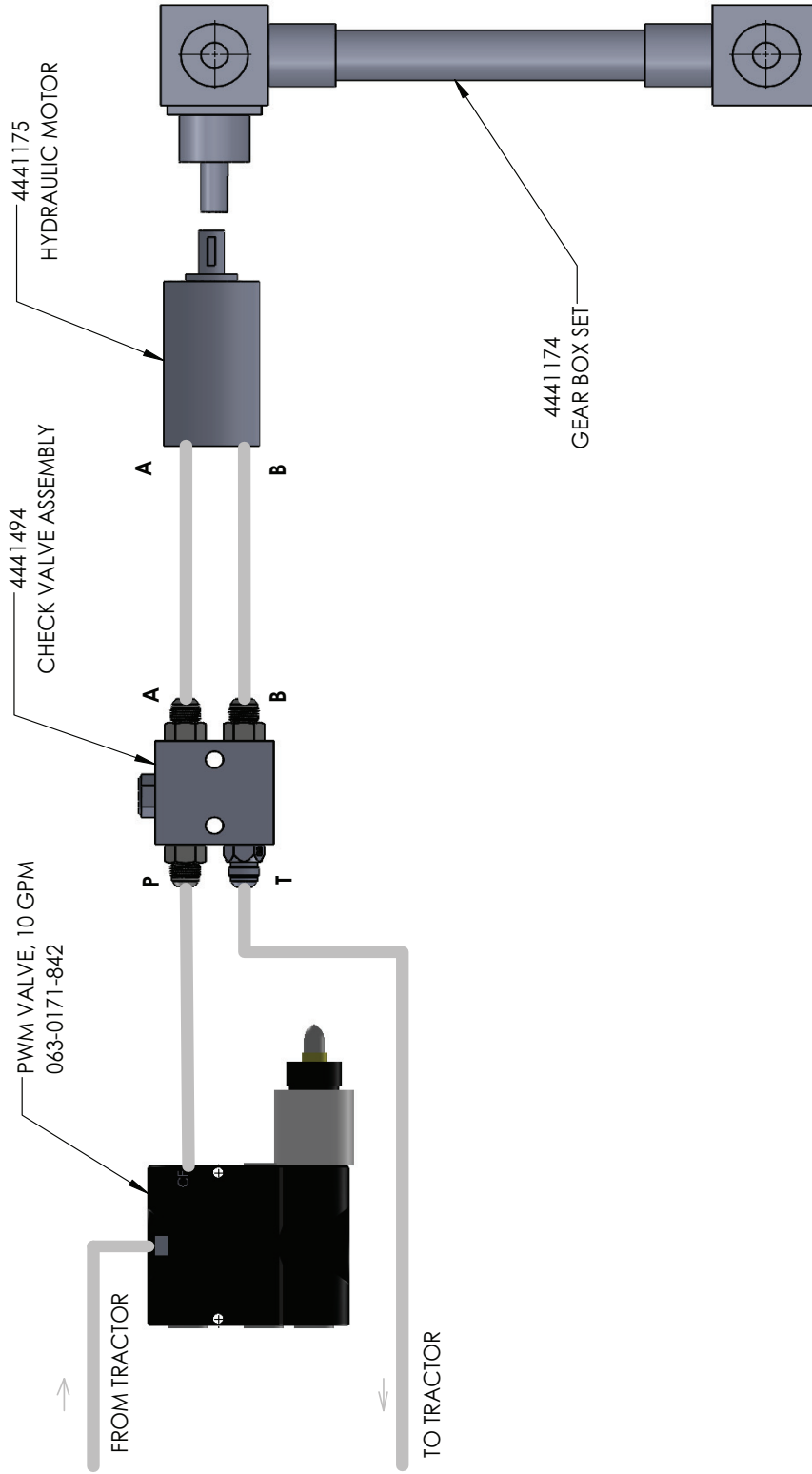

DRAWN BY	Charlie Bowman	2/28/2019		
CHECKED BY				
PRINT DATE	3/10/2021			
CONFIG:	Default			
COMMENTS:				
DWG: 602 E. VAN BUREN ST., LENOX, IA 50851				
MOBILITY HYDRAULIC SPINNER DRIVE LAYOUT, WIDE SPREAD				
SIZE	A	SHEET TITLE:	Sheet1	REV
SCALE:	1:4			SHEET 1 OF 1
C:\epdtn_vault\HARDWARE\PLUMBING\		3	2	1
4		5		

PROPRIETARY AND CONFIDENTIAL
THE INFORMATION CONTAINED IN THIS DRAWING IS THE SOLE PROPERTY OF DALTON AG. ANY REPRODUCTION IN PART OR AS A WHOLE WITHOUT THE WRITTEN PERMISSION OF DALTON AG IS PROHIBITED.

DIGITAL READOUT

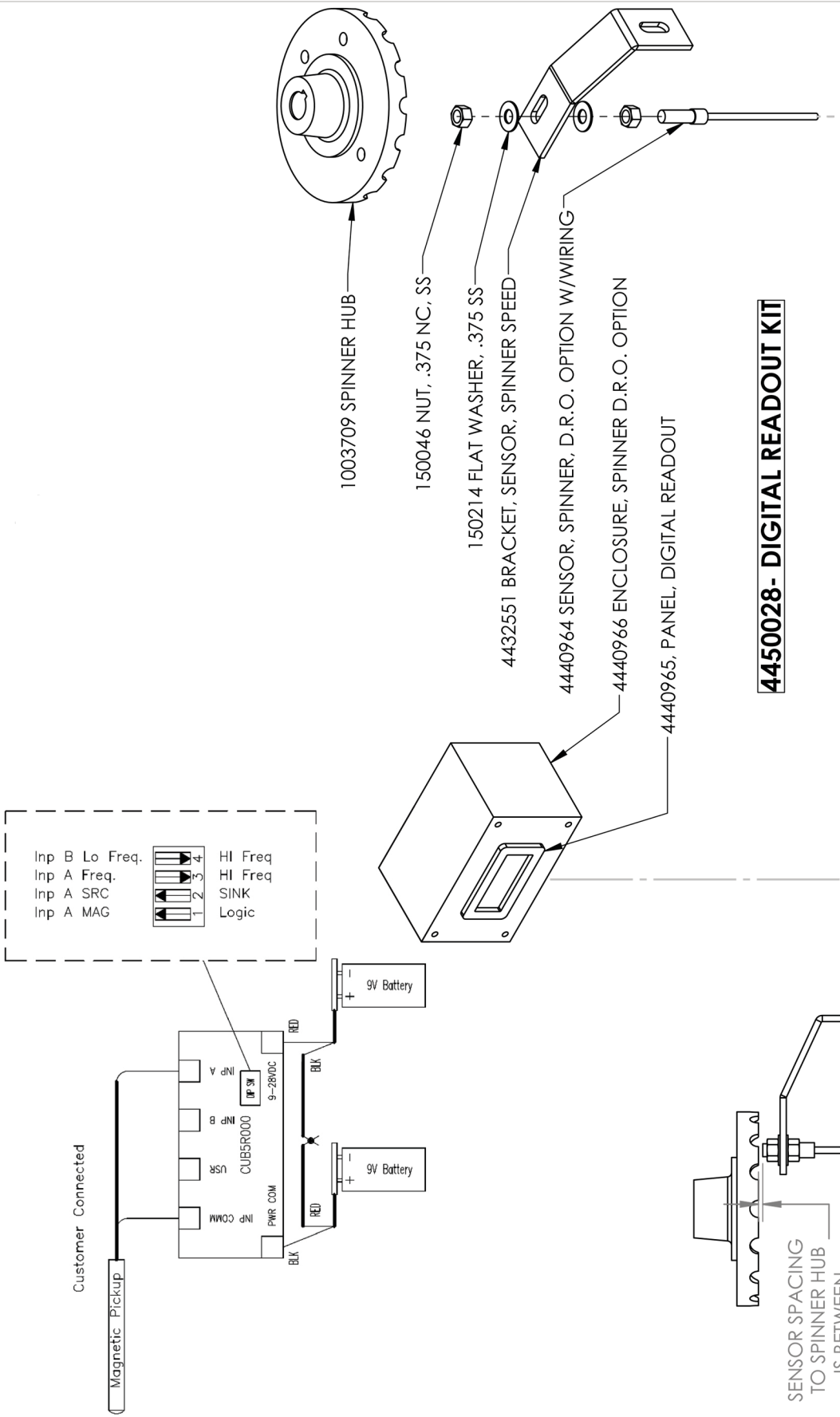

4450028- DIGITAL READOUT KIT

DRAWN BY	L Long	4/12/2017	 <p>602 E. VAN BUREN ST., LENOX, IA 50851</p>
CHECKED BY			
PRINT DATE	1/17/2024		
CONFIG.	Default		
COMMENTS:	DIGITAL READOUT		
<p>PROPRIETARY AND CONFIDENTIAL THE INFORMATION CONTAINED IN THIS DRAWING IS THE SOLE PROPERTY OF DALTON AG. ANY REPRODUCTION IN PART OR AS A WHOLE WITHOUT THE WRITTEN PERMISSION OF DALTON AG IS PROHIBITED.</p>			
SIZE	A	SHEET TITLE:	DIGITAL READOUT
SCALE:	1:4	REV	0
C:\EPDM_Vault\Spreader\Mobility\MS Documents\MS MANUALS\RC 600 & 800\		SHEET 1 OF 1	

1 2 3 4 5

VARIABLE RATE CONTROL, ELECTRICAL PLAN

SCS 660 WITH MASTER SWITCH GRANULAR CONTROL SYSTEM

CONTROL CONSOLE W/ MASTER SWITCH
SCS 660: 063-0172-542

ASTRO II GPS SENSOR
01415

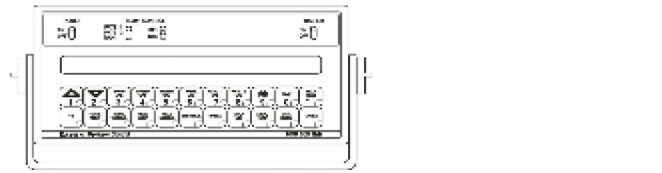

CONSOLE CABLE
3' LONG: 115-0159-707



25' ADAPTER EXT. CABLE
115-0172-556

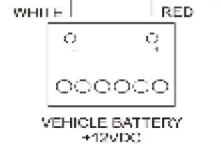

PRODUCT CABLE
115-7347-085

ENCODER
063-0173-937
180 CPR - 50 RPM MAX

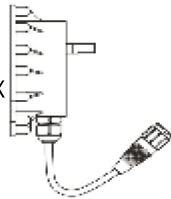

TO SENSORS

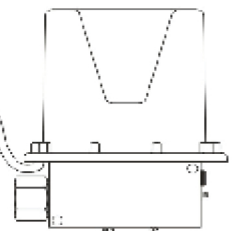

HYDRAULIC CONTROL VALVE
PWM 063-0171-842
OR
FAST 063-0173-162

FAN SENSOR
063-0171-277

DRAWN BY	RICH SMOTHERS
CHECKED BY	
PRINT DATE	
CONFIG.	
COMMENTS:	



PROPRIETARY AND CONFIDENTIAL
THE INFORMATION CONTAINED IN THIS DRAWING IS THE SOLE PROPERTY OF CMC-DALTON AG. ANY REPRODUCTION IN PART OR AS A WHOLE WITHOUT THE WRITTEN PERMISSION OF CMC-DALTON AG IS PROHIBITED.

DWG: VARIABLE RATE CONTROL, ELECTRICAL PLAN

SIZE	SHEET TITLE:	REV
A	ELECTRICAL PLUMBING	A

FOR PARTS, CALL 1.800.342.7498

SCALE: 1:10

SHEET 1 OF 1

VARIABLE RATE CONTROL, HYDRAULIC PLAN

VARIABLE RATE CONTROL, HYDRAULIC PLAN

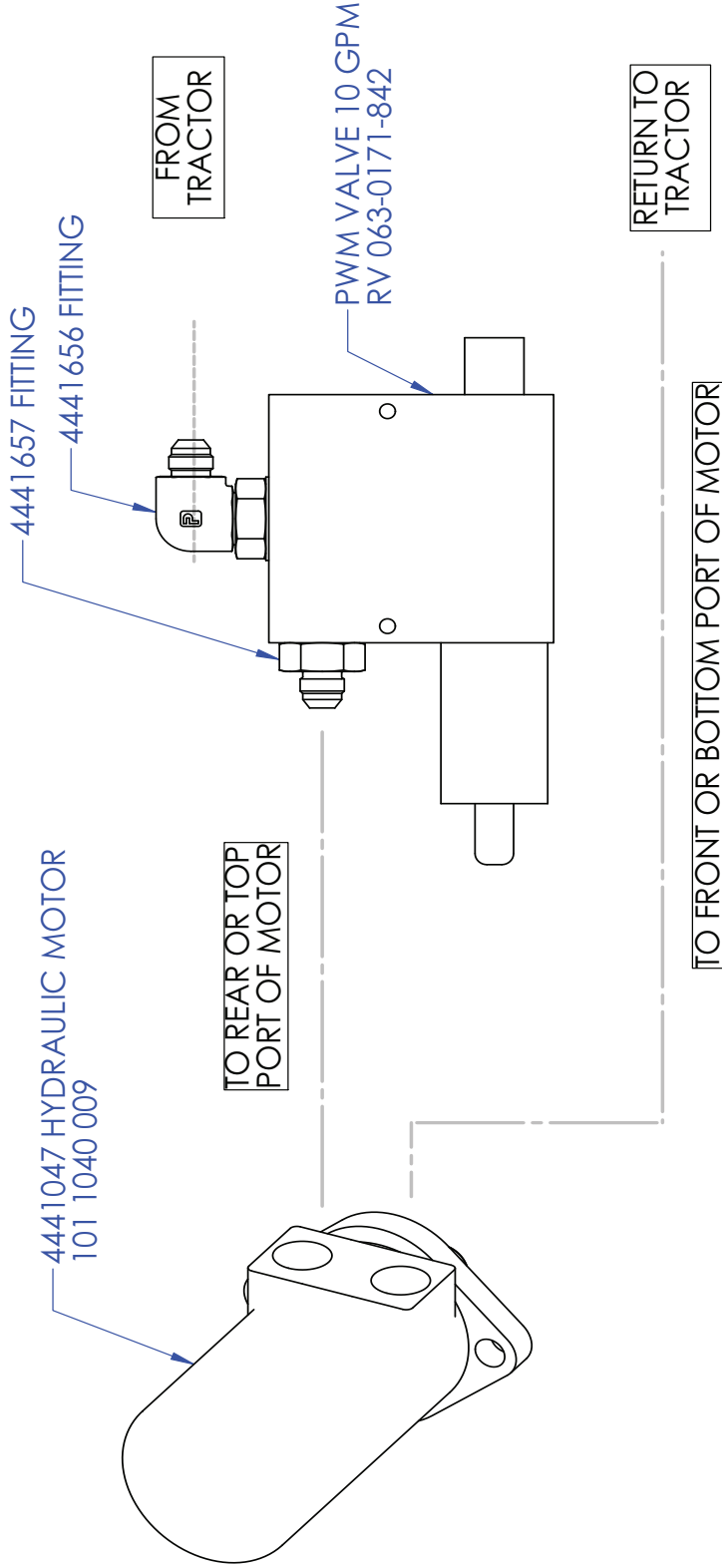

DRAWN BY	RICH SMOTHERS	4/12/2012		
CHECKED BY				
PRINT DATE	3/11/2021			
CONFIG.	FOR DWG			
COMMENTS:	<p>PROPRIETARY AND CONFIDENTIAL THE INFORMATION CONTAINED IN THIS DRAWING IS THE SOLE PROPERTY OF DALTON A.G. ANY REPRODUCTION IN PART OR AS A WHOLE WITHOUT THE WRITTEN PERMISSION OF DALTON A.G IS PROHIBITED.</p>			
<p>DWG: VARIABLE RATE CONTROL, HYDRAULIC PLAN</p>		<p>SIZE A</p>	<p>SHEET TITLE: HYDRAULIC PLUMBING</p>	<p>REV A</p>
<p>FOR PARTS, CALL 1.800.342.7498</p>			<p>SCALE: 1:3</p>	<p>SHEET 1 OF 1</p>
5	4	3	2	1

INITIAL ASSEMBLY HARDWARE, FREIGHT SHIPPING

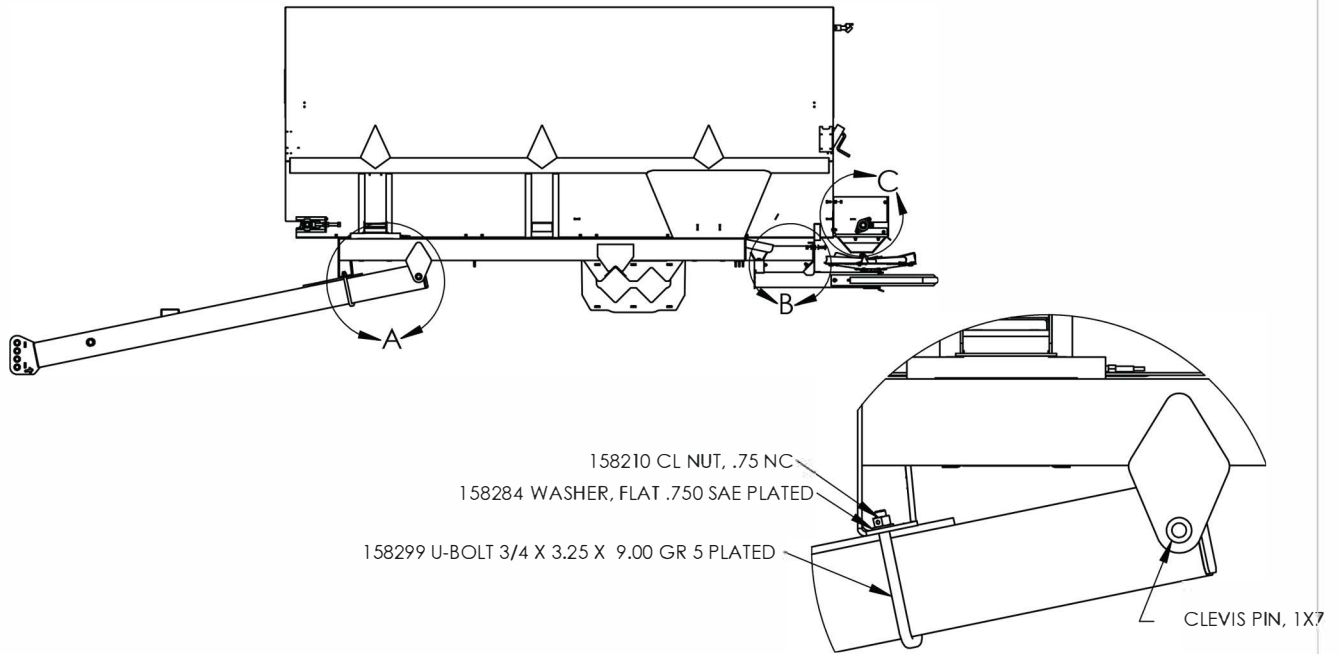

TONGUE ATTACHMENT HARDWARE

DETAIL A
 SCALE 1 : 12

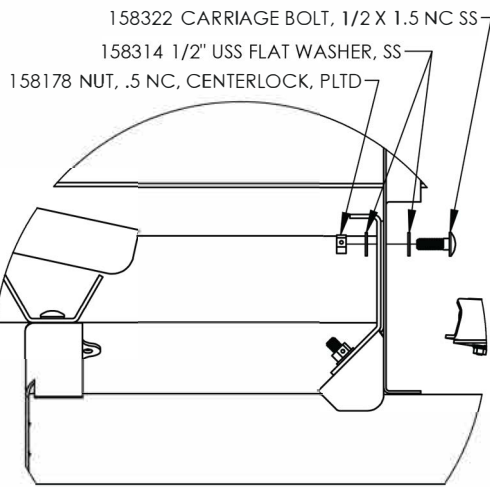

SPINNER A-FRAME ATTACHMENT HARDWARE,
 (6 LOCATIONS)

DETAIL B
 SCALE 1 : 8

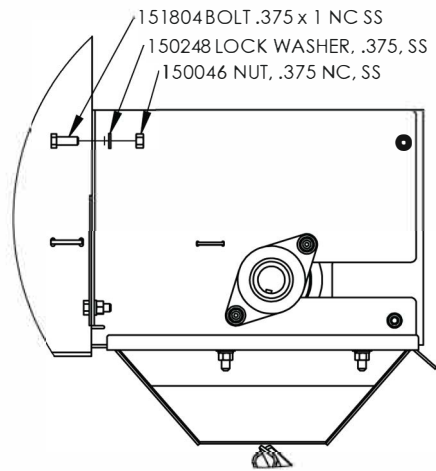

REAR EXTENSION ATTACHMENT HARDWARE,
 (4 LOCATIONS)

DETAIL C
 SCALE 1 : 8

DRAWN BY	--	2/16/2023
CHECKED BY		
PRINT DATE		2/1/2024
CONFIG.	Default	
COMMENTS:		



PROPRIETARY AND CONFIDENTIAL
 THE INFORMATION CONTAINED IN THIS DRAWING IS THE SOLE PROPERTY OF DALTON AG. ANY REPRODUCTION IN PART OR AS A WHOLE WITHOUT THE WRITTEN PERMISSION OF DALTON AG IS PROHIBITED.

DWG:
 INITIAL ASSEMBLY, FREIGHT SHIPPING (1000 & 1200)

SIZE	SHEET TITLE:	REV
A	Sheet1	A

FOR PARTS, CALL 1.800.342.7498

SCALE: 1:96 SHEET 1 OF 1

LOAD CELL & JUNCTION BOX MOUNTING

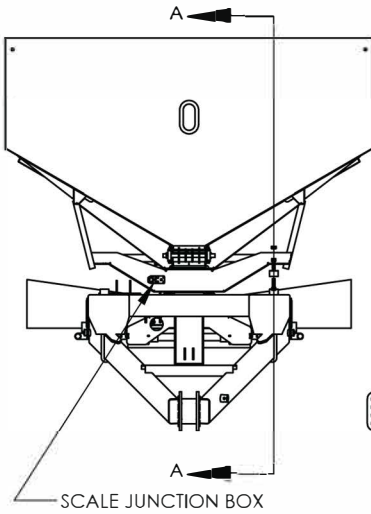

NOTE: SHOWN IN EXPLODED STATE

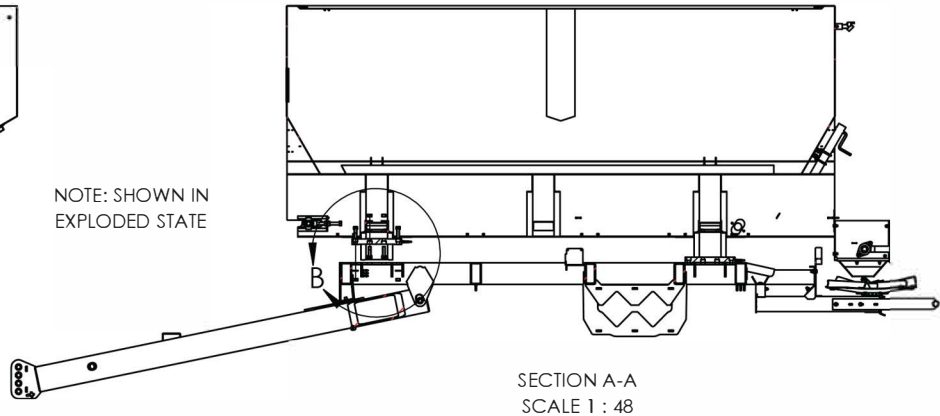

158321 BOLT, 3/4-10 X 2.50, GR 5, SHCS, ZINC PLATED

SPREADER BOX MOUNTING FOOT
40K LOAD CELL
SPREADER FRAME MOUNTING SURFACE

158284 WASHER, FLAT .750 SAE PLATED

158210 CL NUT, .75 NC

NOTE: HARDWARE LISTED IS TYPICAL FOR ALL LOAD CELL MOUNTING POSITIONS.

DETAIL B
SCALE 1 : 10

158162 NUT, NYLON LOCK, 8-32, 8-32 THIN NYLON INS. L/N
158323 #8 FLAT WASHER, SS
INT-137178 SCALE JUNCTION BOX

158324 BOLT, #8-32 X 1.25, GR 5, SS

158324 BOLT, #8-32 X 1.25, GR 5, SS

CABLE POSITIONS:

CABLE POSITIONS	
PLUG POSITION	MACHINE MODEL
	600/800 1000/1200
1 FRONT	FRONT LEFT
2 RIGHT	FRONT RIGHT
3 BACK	REAR LEFT
4 LEFT	REAR RIGHT

DRAWN BY: [Signature] 2/16/2023
 CHECKED BY:
 PRINT DATE: 2/1/2024
 CONFIG: Default
 COMMENTS:



PROPRIETARY AND CONFIDENTIAL
 THE INFORMATION CONTAINED IN THIS DRAWING IS THE SOLE PROPERTY OF DALTON AG. ANY REPRODUCTION IN PART OR AS A WHOLE WITHOUT THE WRITTEN PERMISSION OF DALTON AG IS PROHIBITED.

DWG: LOAD CELL MOUNTING HARDWARE

SIZE: **A** SHEET TITLE: Sheet1 REV: **A**

FOR PARTS, CALL 1.800.342.7498

SCALE: 1:96 SHEET 1 OF 1

Calculate the Spreader Constant Value

The Spreader Constant value can be calculated in one of two ways: by performing a mathematical calculation, or by performing a “catch test” by applying and measuring the product used.

Note: The Spreader Constant value must be recalculated every time the gate opening dimensions are changed!

Formula Calculation:

First, use a tape measure to measure the following dimensions on the machine:

- Gate height (GH) in inches [cm]
 - Gate width (GW) in inches [cm]
 - Distance of travel (D) in inches [cm] of the belt per one revolution of the sensor
- Second, determine the number of pulses emitted by the encoder per one revolution of the sensor.

1. Enter a METER CAL value of 10.

2. Enter a TOTAL VOL value of 0.

3. Turn the sensor exactly one revolution. The value in TOTAL VOLUME is the number of encoder pulses per sensor revolution.

Third, determine the cubic feet [cm] of discharge per one revolution of the sensor by multiplying the distance of the belt travel per one sensor revolution by the gate height by the gate width, then dividing it by 1728 (not necessary for determining cubic cm).

For Example:

Distance of Belt Travel per 1 Sensor Revolution (D) = 13 inches [33 cm]

Gate Height (GH) = 3 inches [18 cm]

Gate Width (GW) = 8 inches [38 cm]

Number of Encoder Pulses per 1 Sensor Revolution (P) = 180 or 360 (Dependent on Encoder)

$$\frac{D \times GH \times GW}{1728} = \text{Cubic Feet of Discharge per 1 Sensor Revolution}$$

$$\frac{13 \times 3 \times 8}{1728} = .181 \text{ cubic feet of discharge per 1 sensor revolution}$$

Finally, calculate the Spreader Constant value using one of the following formulas, using the example of a 180 CPR granular encoder. Write down this number for future reference when programming the console.

Rate in Pounds: *180 Encoder Used As Example*

$$\frac{P}{\text{Cubic Feet of Discharge per 1 Sensor Revolution}} = \text{Spreader Constant Value}$$
$$\frac{180}{.181} = 994 \text{ Spreader Constant}$$

Calibration Numbers for Variable Rate Ready Spreaders ***For 360 Pulse Encoder*** **063-0173-937**

Inches of belt travel per revolution of rear roller = 13"

Encoder pulses per revolution of rear roller = 360

Gate Width = 8"

Gate Height = Actual inches above the floor (chain is ½" thick)

Meter Cal = Product Density

Speed Cal w/ Sky Trak = 600

Speed Cal w/Astro II = 783

Spreader Constant #'s

2" Gate Height = 3000

2.5" Gate Height = 2392

3" Gate Height = 1988

3.5" Gate Height = 1714

4" Gate Height = 1494

4.5" Gate Height = 1328

5" Gate Height = 1200

*The spreader constant is entered by holding down the meter cal. button until the spreader constant menu comes available.

*These numbers are a good starting point and may be need to be adjusted slightly if your actual rate is off.

GATE MARKER DECAL INFO

1000529 - DECAL, GATE HEIGHT MARKER, ALL MOBILITY MODELS

To replace decal:

Place 1/2" material on top of chain, lower gate to material, set pointer at 1"

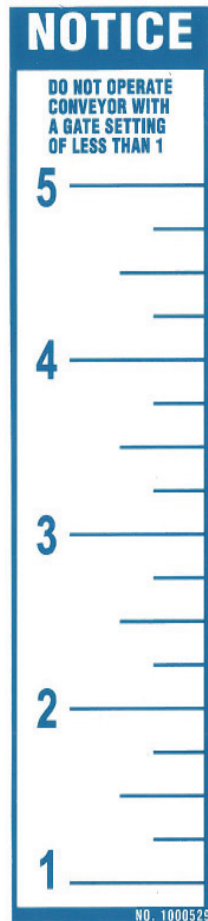

#1000529

RC SPREADER

GROUND DRIVE



140958
641703

1001118-60 1001118-90 1000529 4441679

TRIAID PM17-5920 (ORANGE)

VARIABLE RATE



1001118-VR90

4441679

140958

RC SPREADER



641415
140959

1011304

TRIAID PM17-5910 (YELLOW)

6 ton - 1008931
8 ton - M5014
10 ton - 4441086
12 ton - M5014A



6 ton - 1008931
8 ton - M5014
10 ton - 4441086
12 ton - M5014A

140959

641415



TRIAD PM17-5920

90620 BLUE

1009494 (6 TON)
 1008495 (8 TON)
 4441085 (10 TON)
 4441753 (12 TON)

TRIAD PM17-5910
 MS024-WS

90620 BLUE



TRIAD PM17-5920

MS029

1009494 (6 TON)
 1008495 (8 TON)
 4441085 (10 TON)
 4441753 (12 TON)



MS031

MS030

641702



91284



4441600

4441681



4441680

PARTS ORDERING PROCEDURE

Your Dalton Ag dealer is interested in your new fertilizer application equipment and has the desire to help you get the most value from it. Through the help of this manual, you will find you can do some of the regular maintenance yourself. For parts and service, contact the Dalton Ag Dealership from which you purchased your fertilizer application equipment or your local Dalton Ag dealer.

When replacement parts are required, consult the applicable illustration and parts list to obtain the correct part name and number. When requesting a replacement part, always include the following information:

1. Complete Part Number
2. Description
3. Quantity Required
4. Machine and Model Number
5. Machine Serial Number - located on the topside of the frame near hitch
6. Provide complete name and address for where and how parts are to be shipped.

NOTE: Right and left hand parts and sides of the units are determined by standing at the rear and facing in the direction of forward travel.

EQUIPMENT MODEL: _____

EQUIPMENT SERIAL NO.: _____

DATE OF PURCHASE: _____

NAME OF DEALER: _____

DEALER'S PHONE NUMBER: _____

Thank you for your business!

NOTES

NOTES



www.daltonag.com

602 E. VAN BUREN | LENOX, IOWA 50851 | 800-342-7498