

Dalton

AG PRODUCTS



FERTILIZER APPLICATION EQUIPMENT

SHADOW series



SHADOW ANHYDROUS APPLICATORS



STEALTH LIQUID APPLICATORS



RUNNING GEARS



NURSE TRAILERS



NH3 TOOLBAR DW

20' TO 58' MODELS AVAILABLE

SHADOW series



EXCLUSIVE IMPROVEMENTS

- ◆ 6"X6" HEAVY DUTY FRAME
- ◆ ROBUST PIN ON TONGUE
- ◆ EXTENDED LIFE EDGE BENT SHANKS
- ◆ LONG LIFE DUAL SHANK SPRING
- ◆ EXTREME DUTY SEALER HUBS
- ◆ NO MAINTENANCE WALKER PIVOTS
- ◆ SINGLE POINT DEPTH CONTROL
- ◆ SELF LEVELING REAR HITCH

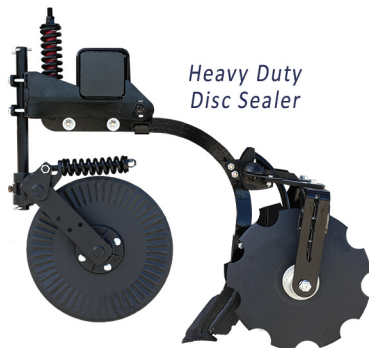

*Heavy Duty
Disc Sealer*

*Various Disc Sealer, Coulter,
Knife and Shank options*



DW SPECIFICATIONS

| DW SERIES TOOLBAR SPECIFICATIONS | | | |
|--|----------------|-----------------|----------------|
| FEATURES | DW CLASS 1 | DW CLASS 2 | DW CLASS 3 |
| Rows | 11 to 14 | 15 to 18 | 19 to 23 |
| Row Spacing | 30" Standard | 30" Standard | 30" Standard |
| Custom Row Spacing | Optional | Optional | Optional |
| Working Width | Up to 35' | Up to 45' | 57.5' |
| Center Section Width | 13' | 13', 14', 15.5' | 15.5', 16' |
| Frame Tubing | 6" x 6" | 6" x 6" | 6" x 6" |
| Rank | 72" | 72" | 72" |
| Heavy Duty Pin On Adjustable Tongue | 6"x6" | 6" x 6" | 6" x 6" |
| Hitch | CAT4 Bull Pull | CAT4 Bull Pull | CAT4 Bull Pull |
| Telescoping/Swinging HD Self - Leveling Rear Hitch | Standard | Standard | Standard |
| Degree of Wing Downflex | 15° | 15° | 15° |
| Wing Sections | 3 Sections | 3 or 5 Sections | 5 Sections |
| Quick Coupler Stand | Standard | Standard | Standard |
| Tires | 320/70 R15 | 320/70 R15 | 320/70 R15 |
| Axles - Lift & Gauge Wheels | Walker | Walker | Walker |
| Hydraulic Outboard Gauge Wheels | N/A | Hydraulic | Hydraulic |
| Greaseless Primary Pivot Points | Standard | Standard | Standard |
| Hydraulic Hose & Gauge Stand | Standard | Standard | Standard |
| Light Kit | Standard | Standard | Standard |
| HP Requirement (Typical Application) | 165-280 | 225-360 | 285-460 |
| 2 Year Main Frame Warranty | Standard | Standard | Standard |
| Single Point Depth Control | Standard | Standard | Standard |
| Powder Coat Paint | Shadow Gray | Shadow Gray | Shadow Gray |



➔ **SCAN ME**
For Pictures & Video

DW

NH3 TOOLBAR

DW C/S SPLIT

SHADOW series



EXCLUSIVE FEATURES

- ◆ 6"X6" HEAVY DUTY FRAME
- ◆ ROBUST PIN ON TONGUE
- ◆ EXTENDED LIFE EDGE BENT SHANKS
- ◆ LONG LIFE DUAL SHANK SPRING
- ◆ EXTREME DUTY SEALER HUBS
- ◆ NO MAINTENANCE WALKER PIVOTS
- ◆ SINGLE POINT DEPTH CONTROL
- ◆ SELF LEVELING REAR HITCH

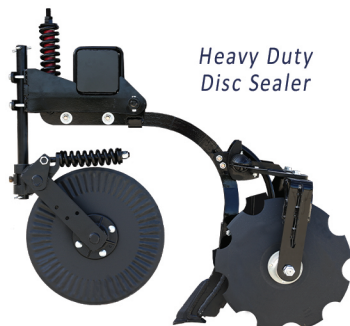

Heavy Duty
Disc Sealer

Various Disc Sealer, Coulter,
Knife and Shank options



COULTER/SHANK SPLIT SPECIFICATIONS

| DW C/S SPLIT SERIES TOOLBAR SPECIFICATIONS | | | |
|---|--------------------------------|-----------------------------------|--------------------------------|
| FEATURES | DW CLASS 1 | DW CLASS 2 | DW CLASS 3 |
| Rows | 11 to 14 | 15 to 18 | 19 to 23 |
| Row Spacing | 30" Standard | 30" Standard | 30" Standard |
| Custom Row Spacing | Optional | Optional | Optional |
| Working Width | Up to 35' | Up to 45' | 57.5' |
| Center Section Width | 13' | 13', 14', 15.5' | 15.5', 16' |
| Frame Tubing | Standard: 6" x 6" | Standard: 6" x 6" | Standard: 6" x 6" |
| Rank | 6" x 6" Frame: 72" | 6" x 6" Frame: 72" | 6" x 6" Frame: 72" |
| Heavy Duty Pin On Adjustable Tongue | Standard: 6" x 6" | Standard: 6" x 6" | Standard: 6" x 6" |
| Hitch | CAT4 Bull Pull | CAT4 Bull Pull | CAT4 Bull Pull |
| Telescoping/Swinging HD Rear Hitch | Standard | Standard | Standard |
| Degree of Wing Downflex | 15° | 15° | 15° |
| Wing Sections | 3 Sections | 3 or 5 Sections | 5 Sections |
| Quick Coupler Stand | Standard | Standard | Standard |
| Tires | Firestone Radial 320/70 R15 | Firestone Radial 320/70 R15 | Firestone Radial 320/70 R15 |
| Axles - Lift & Gauge Wheels | Walker | Walker | Walker |
| Hydraulic Outboard Gauge Wheels (Pin Adjust or Hydraulic) | N/A | Optional: Hydraulic or Pin Adjust | Standard: Hydraulic |
| Greaseless Primary Pivot Points | Standard | Standard | Standard |
| Hydraulic Hose & Gauge Stand | Standard | Standard | Standard |
| Light Kit | Standard | Standard | Standard |
| HP Requirement (Typical Application) | 165-280 | 225-360 | 285-460 |
| 2 Year Main Frame Warranty | Standard | Standard | Standard |
| Single Point Depth Control | Standard | Standard | Standard |
| Powder Coat Paint | Shadow Gray | Shadow Gray | Shadow Gray |



▶▶ **SCAN ME**
For Pictures & Video

C/S SPLIT

NH3 TOOLBAR

Triple Rank

Working width up to 60'

SHADOW series



EXCLUSIVE FEATURES

- ◆ 6"X6" HEAVY DUTY FRAME
- ◆ ROBUST PIN ON TONGUE
- ◆ EXTENDED LIFE EDGE BENT SHANKS
- ◆ LONG LIFE DUAL SHANK SPRING
- ◆ EXTREME DUTY SEALER HUBS
- ◆ NO MAINTENANCE WALKER PIVOTS
- ◆ SINGLE POINT DEPTH CONTROL
- ◆ SELF LEVELING REAR HITCH

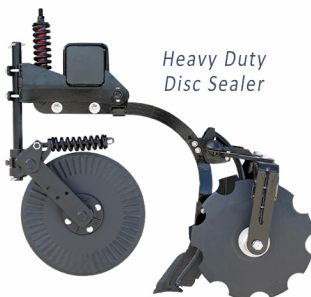

Heavy Duty
Disc Sealer

Various Disc Sealer, Coulter,
Knife and Shank options

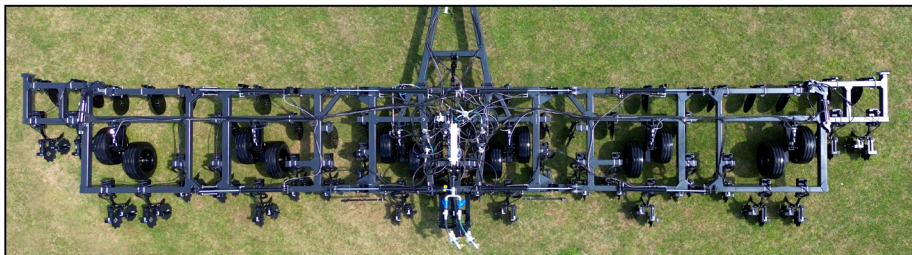

Triple Rank

SPECIFICATIONS

| TR SERIES TOOLBAR SPECIFICATIONS | |
|---|--|
| FEATURES | |
| Rows | 18, 20 or 24 |
| Row Spacing | 30" |
| Working Width | Up to 60' |
| Center Section Width | 14' |
| Transport Height | 14' |
| Transport Width | 18.5' |
| Frame Tubing | 6" x 6" |
| Degree of Wing Downflex | 15 ° |
| Heavy Duty Pin On Adjustable Tongue | Standard |
| Hitch | CAT4 Bull Pull |
| Telescoping/Swinging HD Self - Leveling Rear Hitch | Standard |
| Wing Sections | 18 & 20 - Double fold 22 & 24 - Triple Fold |
| Quick Coupler Stand | Standard |
| Tires | (12) 295/75 R22.5 |
| Axles - Lift & Gauge Wheels | Walking Tandem |
| Hydraulic Outboard Gauge Wheels | Hydraulic Walking Tandem |
| Greaseless Primary Pivot Points | Standard |
| Hydraulic Hose & Gauge Stand | Standard |
| Light Kit | Standard |
| HP Requirement (Typical Application) | 17-20 HP per row or 300-500 |
| 2 Year Main Frame Warranty | Standard |
| Single Point Depth Control | Standard |
| Powder Coat Paint | Shadow Gray |



» SCAN ME
For Pictures & Video

TRIPLE RANK

SHADOW series

NH3 TOOLBAR D 3-POINT HITCH



30" Rank

Hydraulic Wing Lift

Up to 58'6" Working Width

EXCLUSIVE FEATURES

- ◆ 4"X6" HEAVY DUTY FRAME
- ◆ TELESCOPING & SWINGING REAR HITCH
- ◆ HYDRUALIC WING LIFT
- ◆ EXTENDED LIFE EDGE BENT SHANKS
- ◆ LONG LIFE DUAL SHANK SPRING
- ◆ EXTREME DUTY SEALER HUBS
- ◆ HYDRAULIC HOSE AND GAUGE STAND



3-POINT SPECIFICATIONS

| D SERIES (3 POINT) TOOLBAR SPECIFICATIONS | | |
|---|----------------------|----------------------|
| FEATURES | CLASS 1 | CLASS 2 |
| Rows | 9 to 13 | 15 to 23 |
| Row Spacing | 30" Standard | 30" Standard |
| Custom Row Spacing | Optional | Optional |
| Inline Transport | Optional | Optional |
| Working Width | Up to 32' | Up to 55' |
| Center Section Width | 13' | 13', 14', 15.5', 16' |
| Frame Tubing | Standard: 4" x 6" | Standard: 4" x 6" |
| Rank | 30" | 30" |
| Hitch | CAT 3 or 4 - 3 Point | CAT 3 or 4 - 3 Point |
| HD Rear Hitch | Standard | Standard |
| Wing Sections | 3 Sections | 3 or 5 Sections |
| Quick Coupler Stand | Standard | Standard |
| Pin-Type Gauge Wheels | Standard | Standard |
| Greaseless Primary Pivot Points | Standard | Standard |
| Hydraulic Hose & Gauge Stand | Standard | Standard |
| Light Kit | Standard | Standard |
| 2 Year Main Frame Warranty | Standard | Standard |
| Powder Coat Paint | Shadow Gray | Shadow Gray |



➔ **SCAN ME**
For Pictures & Video

3-POINT



SHADOW series

NH3 TOOLBAR DW HIGH SPEED

SAVE YOUR TIME AND INPUT COSTS WITH SPEEDS UP TO 12MPH!

EXCLUSIVE FEATURES

- ◆ 6"X6" HEAVY DUTY FRAME
- ◆ ROBUST PIN ON TONGUE
- ◆ SINGLE POINT DEPTH CONTROL
- ◆ SELF LEVELING REAR HITCH
- ◆ DOWN-FLEX WINGS

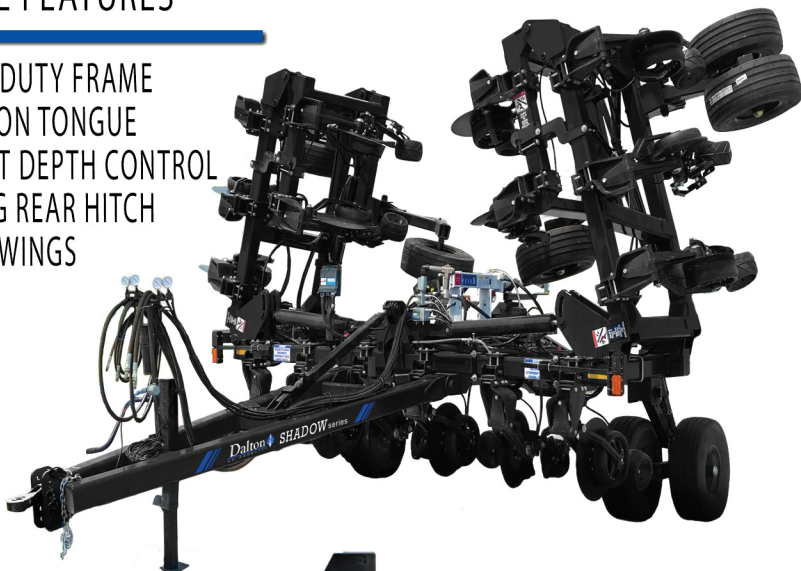

Yetter 10K Magnum



Great for pre-plant and side dress application

Extremely low disturbance

DW HIGH SPEED SPECIFICATIONS

| DW HIGH SPEED SERIES TOOLBAR SPECIFICATIONS | | | |
|--|-------------------|-------------------|-------------------|
| FEATURES | DW CLASS 1 | DW CLASS 2 | DW CLASS 3 |
| Rows | 11 to 14 | 15 to 18 | 19 to 23 |
| Row Spacing | 30" Standard | 30" Standard | 30" Standard |
| Custom Row Spacing | Optional | Optional | Optional |
| Working Width | Up to 35' | Up to 45' | 57.5' |
| Center Section Width | 13' | 13', 14', 15.5' | 15.5', 16' |
| Frame Tubing | 6"x 6" | 6" x 6" | 6" x 6" |
| Rank | 54" | 54" | 54" |
| Heavy Duty Pin On Adjustable Tongue | 6"x6" | 6" x 6" | 6" x 6" |
| Hitch | CAT4 Bull Pull | CAT4 Bull Pull | CAT4 Bull Pull |
| Telescoping/Swinging HD Self - Leveling Rear Hitch | Standard | Standard | Standard |
| Degree of Wing Downflex | 15 ^o | 15 ^o | 15 ^o |
| Wing Sections | 3 Sections | 3 or 5 Sections | 5 Sections |
| Quick Coupler Stand | Standard | Standard | Standard |
| Tires | 320/70 R15 | 320/70 R15 | 320/70 R15 |
| Axles - Lift & Gauge Wheels | Walker | Walker | Walker |
| Hydraulic Outboard Gauge Wheels | N/A | Hydraulic | Hydraulic |
| Greaseless Primary Pivot Points | Standard | Standard | Standard |
| Hydraulic Hose & Gauge Stand | Standard | Standard | Standard |
| Light Kit | Standard | Standard | Standard |
| HP Requirement (Typical Application) | 165-280 | 225-360 | 285-460 |
| 2 Year Main Frame Warranty | Standard | Standard | Standard |
| Row Units | Yetter 10K Magnum | Yetter 10K Magnum | Yetter 10K Magnum |
| Powder Coat Paint | Shadow Gray | Shadow Gray | Shadow Gray |



▶ **SCAN ME**
For Pictures & Video

DW HIGH SPEED

Dalton 
A G P R O D U C T S

LIQUID APPLICATORS

STEALTH SERIES

EXCLUSIVE FEATURES

- ◆ VRT READY
- ◆ HEAVY DUTY STEEL TUBE FRAME
- ◆ VERSATILE CUSTOM ROW SPACING
- ◆ SUPERIOR GROUND CLEARANCE
- ◆ INJECTION OR KNIFE OPTIONS
- ◆ GREASLESS WING PIVOT POINTS
- ◆ OPTIONAL GULL WING
- ◆ OPTIONAL PIN TYPE GAUGE WHEEL

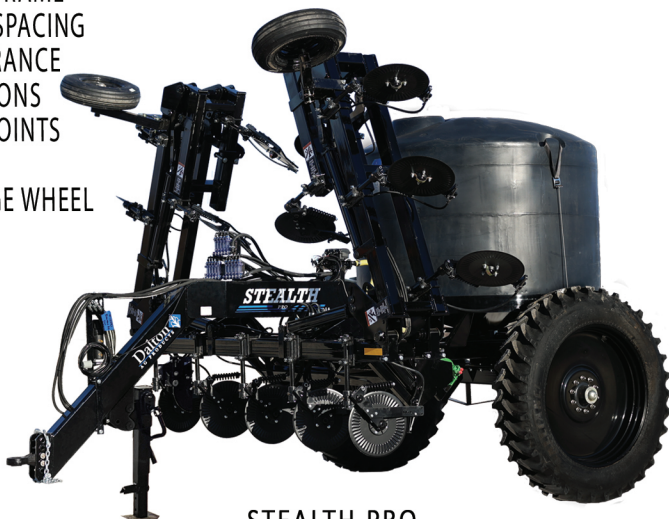

STEALTH PRO



STEALTH ELITE

MODELS AND OPTIONS TO
FIT YOUR OPERATIONS!



LIQUID APPLICATORS

SPECIFICATIONS

| STEALTH SERIES LIQUID FERTILIZER APPLICATOR | | | |
|---|--------------------------------------|--|--|
| FEATURES | STEALTH | STEALTH PRO | STEALTH ELITE |
| Rows | 11 to 15 | 11 to 23 | 11 to 23 |
| Row Spacing | Standard: 30" | Standard: 30" Custom Spacing Available | Standard: 30" Custom Spacing Available |
| Working Width | Up to 35' | Up to 60' | Up to 60' |
| Center Section Width | 10.7', 13', 15.5' | 10.7', 13', 15.5' | 10.7', 13', 15.5' |
| Toolbar Frame | 7" x 7" Steel Tubing (Single Row) | 4" x 6" Steel Tubing (Double Row) | 4" x 6" Steel Tubing (Double Row) |
| Bar | 11 Knife or 11-15 Knife combo | 11-15 Knife combo 13-17 Knife combo 23 Knife | 11-15 Knife combo 13-17 Knife combo 23 Knife |
| Crop Clearance to Toolbar Frame when Raised | 49" | 53" | 53" |
| Liquid Delivery Mode | Injection or Knife | Injection or Knife | Injection or Knife |
| Pump Drive System | Ground Drive or Hydraulic Drive | Ground Drive or Hydraulic Drive | Ground Drive or Hydraulic Drive |
| Two-Speed Jack | Standard | Standard | Standard |
| Hitch | CAT4 Bull Pull | CAT4 Bull Pull | CAT4 Bull Pull |
| Axle | 120" | 120" | 120" |
| Parallel Linkage System | Standard | Standard | Standard |
| Tank Type | Cone Bottom | Cone Bottom | Drainable |
| Tank Size | 1,000 Gallon | 1,300 or 1,750 Gallon | 1,610 or 2010 Gallon |
| Tires & Wheels | 320/90/R46 | 380/90/R46 VF 380/90 R46 - 1,750 tank | VF 380/90 R46 |
| Greasless Primary Wing Pivot Points | Standard | Standard | Standard |
| Hand Wash Station | Standard: 3 Gallon | Standard: 3 Gallon | Standard: 3 Gallon |
| Light Kit | Standard | Standard | Standard |
| Gull Wing Feature | Optional | Optional Standard on 23 row | Optional Standard on 23 row |
| Down Pressure Feature | Optional | Optional | Optional |
| Manual Gauge Wheels | Optional | Optional | Optional |
| Frame Warranty | 24 Months | 24 Months | 24 Months |
| Powder Coat Paint | Black | Black | Black |



▶ **SCAN ME**
For Pictures & Video

LIQUID APPLICATORS

RUNNING GEARS

- ◆ WN SERIES: (REACH POLE) 1300,1600,1800,2000
- ◆ WNDT-GN: 1000-DUAL 1000 GAL.
1500-DUAL 1450 GAL.
2000-SINGLE 2000 GAL.
3000-SINGLE 3000 GAL.
WNDT-GN SA SINGLE AXLE



GN Tandem Axle



GN Single Axle

RUNNING GEARS

SPECIFICATIONS

| WN Reach Pole Wagons | | | | |
|----------------------|--------------------------------------|--|--|----------------------|
| Features | WN1300 | WN1600 | WN1800 | WN2000 |
| Tank | (1) 1000 gal. | (1) 1000 or 1450 gal. | (1) 1000 or 1450 gal. | (1) 2000 gal. |
| Track Width Standard | 72" Front & Rear | 80" Front & Rear | 80" Front & Rear | 80" Front & Rear |
| Track Width Optional | 60", 90" Fixed 60"-80" Adjustable | 60", 90", 120" Fixed 60"-80" Adjustable | 60", 90", 120" Fixed 60"-80" Adjustable | 60", 90", 120" Fixed |
| Hubs | 6-Bolt | 6-Bolt | 8-Bolt | 8-Bolt |
| Wheels/Tires | Optional | Optional | Optional | Optional |
| Lift Assist Tongue | Optional | Optional | Optional | Optional |
| Extendable Tongue | Optional | Optional | Optional | Optional |
| Bolt-On Step | Optional | Optional | Optional | Optional |
| High Clearance Kit | Optional | Optional | Optional | Optional |
| Powder Coat Paint | Standard | Standard | Standard | Standard |
| 24 Month Warranty | Standard | Standard | Standard | Standard |

| WNDT Gooseneck Wagons | | | | | |
|---|--|-----------------|-----------------------|----------------------|----------------------|
| Features | WNDT SA | WNDT1000 GN | WNDT1500 GN | WNDT2000 GN | WNDT3000 GN |
| Tanks | (2) 1000 or 1450 gal. (1) 2000 or 3000 gal. | (2) 1000 gal. | (2) 1450 gal. | (1) 2000 gal. | (1) 3000 gal. |
| Rear Axle | Single | Walking Tandem | Walking Tandem | Walking Tandem | Walking Tandem |
| Track Width | 60" Front - 102" Rear | 60" Front - 93" | 60" Front - 102" Rear | 60" Front - 95" Rear | 60" Front - 95" Rear |
| Tires | Used 425/225 | Used 425/225 | Used 425/225 | Used 425/225 | Used 425/225 |
| Spring Assist Tongue | Standard | Standard | Standard | Standard | Standard |
| Plumbing Hoop | Standard | Standard | Standard | Standard | Standard |
| Bolt-On Step - (1) | Standard | Standard | Standard | Standard | Standard |
| Lights | Optional | Optional | Optional | Optional | Optional |
| Extendable Tongue (Included with brake option) | Optional | Optional | Optional | Optional | Optional |
| 2 Wheel Surge Brakes | Optional | Optional | Optional | Optional | Optional |
| 4 Wheel Surge Brakes | Optional | Optional | Optional | Optional | Optional |
| 120" Rear Axle | Optional | Optional | Optional | Optional | Optional |
| Hose Holder | Optional | Optional | Optional | Optional | Optional |
| Powder Coat Paint | Standard | Standard | Standard | Standard | Standard |
| 24 Month Warranty | Standard | Standard | Standard | Standard | Standard |



» SCAN ME
For Pictures & Video

RUNNING GEARS

Dalton
A G P R O D U C T S



NURSE TRAILERS M SERIES

Heavy duty steel frame

Universal pump mount

Various wheel and tire options



MC Single



MC Double

NURSE TRAILERS

SPECIFICATIONS

| DALTON AG PRODUCTS NURSE TRAILER SPECIFICATIONS | | | | | |
|---|------------------------|------------------------|------------------------|-------------|-------------------------|
| FEATURES | M1010 | M1315 | M1610 | MC Single | MC Double |
| Optional Drainable Tank | 1010 Gallon with Hoops | 1315 Gallon with Hoops | 1610 Gallon with Hoops | 1300 Gallon | (2) 2500 or 3000 Gallon |
| Heavy Duty Steel Frame | Standard | Standard | Standard | Standard | Standard |
| Tire Options | 11Lx15 | 12.5Lx15 | | 12.5Lx15 | |
| | 235/85/16 | 235/85/16 | 255/70 R22.5 | 320/70 R15 | 11Lx15 |
| | 280/70 R15 | 255/70 R22.5 | | 255/22.5 | |
| 2 Wheel Surge Brakes | Optional | Optional | Standard | Optional | N/A |
| 4 Wheel Surge Brakes | Optional | Optional | Optional | Optional | N/A |
| 4' Deck Extension | Optional | Optional | Optional | Optional | N/A |
| Bolt-On Step | Optional | Optional | Optional | Optional | N/A |
| Light Kit | Optional | Optional | Optional | Optional | Optional |
| Bolt-On Fenders | Optional | Optional | Optional | Optional | N/A |
| Powder Coat Paint | Black | Black | Black | Black | Black |
| 24 Month Warranty | Standard | Standard | Standard | Standard | Standard |

CUSTOMIZE YOUR NEW TRAILER WITH
MULTIPLE OPTIONAL FEATURES!



Optional Bolt-On Fenders

4' Deck Extension



NURSE TRAILERS

▶▶ SCAN ME
For Pictures & Video

Dalton
AG PRODUCTS

DALTON EDGE SHANK ROW UNIT (D.E.S.)

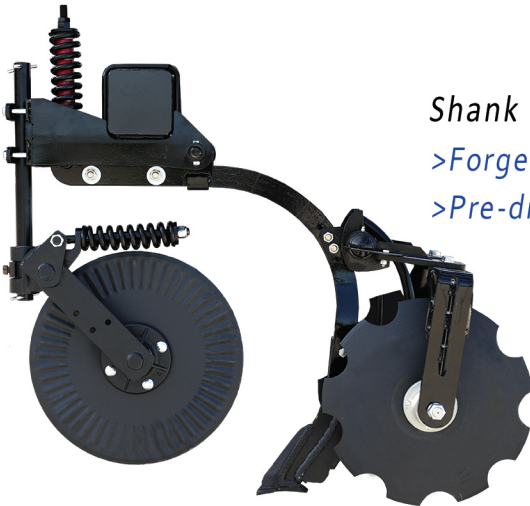

Shank

- >Forged for strength and longevity
- >Pre-drilled holes for disc sealer



Redesigned Bottom Bracket
-reinforced shank rocker
-eliminates top plate with
a U-bolt mount



Sealed Hub
-maintenance free
for longer life

Urethane Inner Spring

U-Bolt Mount

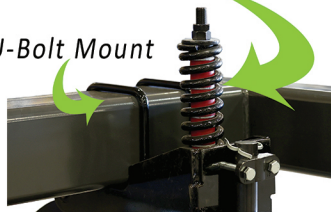

SCAN ME
For Pictures & Video

ROW UNIT ACCESSORIES

DISC SEALERS



KNIVES

Standard Knife



Mole Knife



Mini Mole Knife



COULTERS





YOUR PARTNER IN
FERTILIZING THE FUTURE



MANUFACTURED BY DALTON AG
602 E. VAN BUREN ST. LENOX, IA 50851
1-800-342-7498 | OFFICE@DALTONAG.COM
WWW.DALTONAG.COM