



OPERATING AND PARTS MANUAL

SHADOW SERIES

TRIPLE RANK TOOLBAR

2025

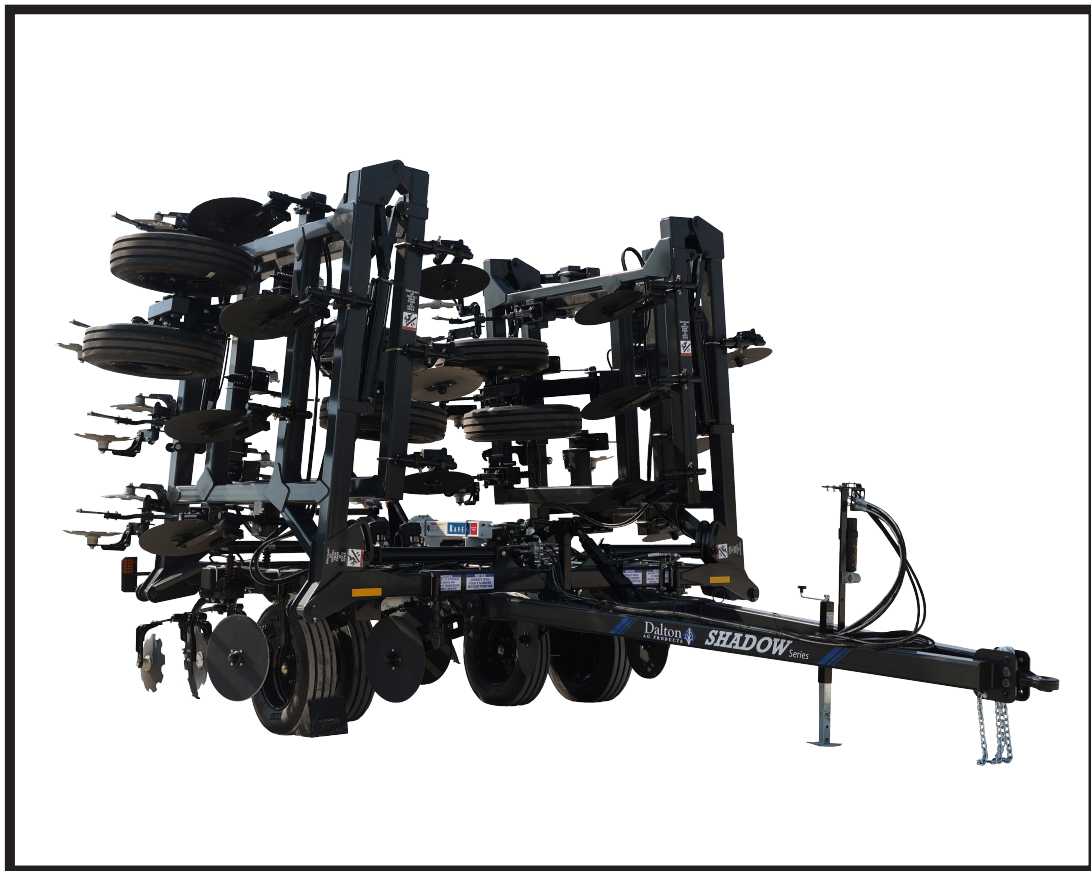

TABLE OF CONTENTS

TO YOU THE OWNER.....	1
LIMITED WARRANTY STATEMENT.....	2
NEW MACHINE CHECKOUT.....	3
IMPLEMENT SAFETY.....	4
PRE-SEASON CHECK.....	5
BOLT TORQUE CHART	6
ANHYDROUS SAFETY	7
FIRST AID.....	11
OPERATING & INSTALLATION INSTRUCTIONS FOR THE A-HFC-114.....	13
PURGING INSTRUCTIONS FOR REPHASING CYLINDERS.....	18
BULL PULL TONGUE & HOSE STAND ASSEMBLY.....	19
TOOLBAR WHEEL LIFT CYLINDER LAYOUT.....	21
TOOLBAR WING CYLINDER LAYOUT.....	22
WING FOLD SEQUENCING VALVE.....	23
TRIPLE RANK INBOARD FOLD HARDWARE.....	24
TRIPLE RANK OUTBOARD FOLD.....	25
TRIPLE RANK FRONT FOLD LINKAGE.....	26
CYLINDER LOCKS & HARDWARE.....	27
TOOLBAR LIGHT KIT.....	28
SLH MOUNTING HARDWARE.....	29
REAR HITCH, SLH.....	30
LIFT ARM WALKERS.....	31
WALKERS UNIT BEARING.....	32
8-BOLT HUB ASSEMBLY.....	33
DEPTH CONTROL ASSEMBLY.....	34
DEPTH CONTROL ASSEMBLY Cont.....	35
DEPTH CONTROL VALVE PLUMBING.....	36
DEPTH CONTROL ASSEMBLY Cont.....	38
4410912, EDGE HD DISC SEALER.....	37
4410912-OS EDGE HD OFF SET DISC SEALER.....	38
4410925 EDGE HD SPRING LOADED DISC SEALER.....	39
4410926 HD SIDE DRESS DISC SEALER.....	40
STANDARD EDGE SHANK AND KNIVES.....	41
4410920 EDGE SPRING LOADED SHANK CLAMP, 6X6, COMPLETE.....	42
GROVE COULTER ASSEMBLY.....	44
YETTER 20" COULTER ASSEMBLY	45
YETTER 24" EXTREME COULTER ASSEMBLY.....	46
YETTER 20" & 24" EXTREME HUB BREAKDOWN.....	47
INSTALLATION INSTRUCTIONS FOR AG LIGHTS.....	48
DECAL LAYOUT.....	49
PARTS ORDERING PROCEDURE.....	50

TO YOU THE OWNER

Your Dalton Ag Equipment is the most modern, up-to-date, versatile, machine available for fertilizer application. The machine is the result of many years of experience, research, development and testing of equipment for fertilizer application. It is soundly engineered and carefully built to rigid specifications. It is of rugged and simple construction, with a minimum of moving parts.

However, to obtain maximum performance from your Dalton Ag Equipment, it is necessary to follow the instructions and safety suggestions in this manual. Each section has been carefully prepared for the purpose of providing needed and valuable information to the owner and operator. Each operator of this unit should be familiar with the contents of this manual. Keep it in a safe and convenient location. THERE ARE MANY SAFETY SUGGESTIONS (CAUTION AREAS) PRINTED THROUGHOUT THIS MANUAL. CAREFULLY READ THEM ALL BEFORE OPERATING THIS UNIT.

DESIGN IMPROVEMENTS

Dalton Ag Products follows a policy of continuous products improvement. We therefore reserve the right to make design improvements, and changes in specifications and prices, without incurring obligations to make revisions or additions to equipment previously sold.

**REGISTER
WARRANTY
ONE OF FOUR
WAYS**

- Register on-line at:
www.daltonag.com
- Fax your completed warranty registration form to:
641-569-7033
- Email your completed warranty registration form to:
office@daltonag.com
- Mail your completed warranty registration form to:
Dalton Ag Products
P.O. Box 70
Lenox, IA 50851

LIMITED WARRANTY STATEMENT

DALTON AG PRODUCTS warrants to the original purchaser only that all products manufactured under the Dalton Ag and Mobility Brands will be free from defects in material and workmanship under normal use and service.

DALTON AG’s obligation under this warranty is limited to repairing or replacing, as it may elect, free of charge and without charge for installation, at the place of business of a dealer or distributor authorized to handle the equipment covered by this warranty or at a DALTON AG facility, any parts that prove, in DALTON AG's judgment, to be defective in material or workmanship within two (2) years after delivery to the original purchaser. DALTON AG shall not be liable for personal injuries or any special or consequential damages of any kind, either direct or indirect. This warranty is subject to acts of God, fire and existing conditions of supply and demand, production, ability or inability to deliver, or for any other valid reason beyond the reasonable control of DALTON AG. No distributor, dealer, agent or DALTON AG employee (other than DALTON's President in writing) is authorized to extend or make any other or further express or implied warranty or incur any additional obligation on DALTON AG’s behalf in connection with the sale of this product.

Customer Responsibility

Product Registration - It is a condition of this warranty that the original purchaser fill out the warranty card furnished by DALTON AG and return it to DALTON AG to be recorded in DALTON AG’s owner file. Registration may also be done on line at www.DaltonAg.com/warrantyregistration. If the original purchaser's card or electronic registration is not on file at DALTON AG’s office, the warranty period will extend only from date equipment was picked up or shipped from the DALTON AG plant.

Maintenance - It is the customer’s responsibility to maintain their equipment in accordance with the instructions provided in the Operator’s Manual. DALTON AG recommends that you keep records and receipts as the customer may be required to verify the maintenance instructions have been followed.

Operation – It is the customer’s responsibility to operate the equipment only for the purpose for which it was designed and in accordance with all safety and operational recommendations contained in the Operator's Manual. If a defect in materials or workmanship occurs, it is the customer’s responsibility to cease operating the equipment until authorized repairs are made.

Damage incurred from continued operation after a defect is discovered may not be covered by this warranty.

What this Warranty Covers

This warranty covers failures caused by defects in materials or workmanship only.

This Warranty does not cover failures caused by:

- Improper operation
- Natural calamities
- Unauthorized modifications
- Unauthorized repairs
- Use of Non DALTON AG parts
- Neglected maintenance
- Usage contrary to the intended purpose of the product

This Warranty does not cover replacement of Wear or Maintenance Items including, but not limited to:

- Lubricants
- Filters
- Hoses
- Tires
- Disks
- Chains
- Idlers
- Blades
- Belts
- Bearings

This Warranty does not cover:

- Pickup and delivery of the equipment
- Service Calls or Travel Time to and from sites
- Rental of replacement equipment during repair period
- Products that have been declared a total loss and subsequently salvaged
- Overtime labor charges

Parts Warranty

DALTON AG warrants its replacement parts against defects in materials or workmanship for a period of 90 days or the remainder of the product warranty, whichever is longer under the terms set out above. Remedy for defective replacement parts for units that are beyond the original product warranty, will be limited to replacement of the failed part.

NEW MACHINE CHECKOUT

1. All hardware properly tightened.
2. Lubrication of grease fittings.
3. Wheel bolts tightened to proper specs.
4. Check hydraulic hoses and fittings.

MAINTENANCE

1. Visually inspect machine daily.
2. Repair or replace any worn or damaged parts.

LUBRICATION SCHEDULE

Careful observance of the following lubrication schedule is the best preventative maintenance program for your Dalton Ag Equipment. We recommend that you establish a firm program to insure lubrication in strict compliance with the following schedule. Use only good grade pressure gun type grease unless otherwise specified.

Daily Lubrication

Hinge points

Weekly Lubrication

Wheel bearings
Coulters

Annual Lubrication

Check all bearings - repack or replace as needed

IMPLEMENT SAFETY

In addition to design and configuration of equipment, safety and accident prevention are dependent upon the awareness, concern, and proper training of personnel involved in the operation, transport, maintenance, and storage of equipment. Failing to follow these safety messages can result in machine damage, personal injury, and/or death.

- Before operating your DALTON AG equipment, thoroughly read and understand your operator's manual. If you do not understand any portion of the operator's manual, contact your local Dalton Ag dealer immediately for clarification.
- Furnish this manual to a new operator.
- Tow with tractor only. Never transport equipment in excess of 20 MPH. Maintain a safe speed.
- Use a Slow-Moving-Vehicle (SMV) emblem when transporting.
- Be sure safety decals are readable. All safety related decals must be replaced if the equipment is painted or the decals are otherwise rendered unreadable.
- Install transport link before transporting.
- Always check for overhead obstacles in transporting equipment and before folding or unfolding the wings of the unit.
- Never permit riders on the equipment or tractor.
- Proceed slowly on rough or slippery roadways, on side hills, and around curves to avoid tipping.
- Reduce speed when approaching ditches and corners. Do not make sharp turns with brakes.
- Machinery should be operated only by persons familiar to the tractor, equipment, and the safety related items.
- Do not stand on, or straddle tongue when unhitching.
- Do not modify or permit anyone to modify this equipment and any of its components without first consulting your Dalton Ag dealer.
- Do not lubricate, adjust, or repair when equipment is in motion.
- Use only approved replacement parts.
- To prevent serious injury from high pressure fluid, NEVER attempt to inspect, service, or disassemble any part of the hydraulic system until all pressure is relieved by lowering the toolbar to the ground (or secure with cylinder transport stops provided).
- High-pressure fluid is nearly invisible but has enough force to penetrate the skin. Never use the hands to search out a suspected leak. If injured by escaping fluid, obtain medical attention at once to minimize chance of infection. Wear safety glasses or goggles to avoid eye injury when working on the hydraulic system.
- Always check torque on wheel bolts before transporting.

PRE-SEASON CHECK

1. Carefully review the safety suggestions in this manual.
2. Check all bolts for proper tightness. When the implement is new, check after one hour and every few hours of operation.
3. Replace ground tools that are severely worn, broken or damaged.
4. Check tires for proper inflation. All tires should be inflated equally to avoid side draft.
5. Check the wheel lug bolts daily, keep wheel bolts tight.
6. Grease all fittings.
7. Inspect, repack, or replace (if necessary) wheel bearings and seals.
8. Check hoses, hose routing and hydraulic cylinders. Any indication of leakage or fraying of hoses should be corrected.





OFF SEASON STORAGE

Following these suggestions will extend service life and satisfaction:

1. A little time and effort spent cleaning your machine before storing will repay in longer service, easier operation and higher resale value.
2. Inspect for worn or damaged parts. Replace, if required, and avoid delays the next season.
3. Repaint all areas where the original paint is worn off.
4. Lubricate your implement.
5. Grease all exposed metal surfaces of ground tools.
6. Store the unit inside a shed to protect from weather and on a level area with wings down. The ground working parts should rest on boards.
7. Disconnect the rod end of the lift cylinders and retract the rod into the cylinder to prevent the cylinder rod from rusting.
8. Cap or plug all hydraulic oil lines, if the cylinders are removed. This is to prevent any contaminants from entering the hydraulic system.
9. Raise tires off ground or remove and store in cool dry location out of sunlight.

IMPORTANT Over tightening hardware can be as damaging as under tightening. Tightening beyond recommended torque will reduce the fastener's shock load capacity.

BOLT TORQUE CHART

SIZE	 SAE GRADE 2		 SAE GRADE 5		 SAE GRADE 8		 L9
	ASSEMBLY TORQUE DRY	LUBRICATED	ASSEMBLY TORQUE DRY	LUBRICATED	ASSEMBLY TORQUE DRY	LUBRICATED	ASSEMBLY TORQUE LUBRICATED
1/4-20	66*	49*	8	75*	12	9	11
1/4-28	76*	56*	10	86*	14	10	13
5/16-18	11	8	17	13	20	18	21
5/16-24	12	9	19	14	25	20	23
3/8-16	20	15	30	23	45	30	33
3/8-24	23	17	35	25	50	35	38
7/16-14	30	24	50	35	70	55	60
7/16-20	35	25	55	40	80	60	65
1/2-13	50	35	75	55	110	80	95
1/2-20	55	40	90	65	120	90	105
9/16-12	65	50	110	80	150	110	140
9/16-18	75	55	120	90	170	130	150
5/8-11	90	70	150	110	220	170	185
5/8-18	100	80	180	130	240	180	205
3/4-10	160	120	260	200	380	280	290
3/4-16	180	140	300	220	420	320	355
7/8-9	190	140	400	300	600	460	505
7/8-14	210	155	440	320	660	500	585
1-8	220	160	580	440	900	680	775
1-14	240	170	640	480	1000	740	900
1 1/8-7	300	220	800	600	1280	960	1150
1 1/8-12	340	260	880	660	1440	1080	1325
1 1/4-7	420	320	1120	840	1820	1360	1600
1 1/4-12	460	360	1240	920	2000	1500	1750
1 3/8-6	560	420	1460	1100	2380	1780	---
1 3/8-12	640	460	1680	1260	2720	2040	---
1 1/2-6	740	560	1940	1460	3160	2360	3250
1 1/2-12	840	620	2200	1640	3560	2660	3650

**ITEMS WITH * = INCH POUNDS
ALL OTHERS = FOOT POUNDS**

WARNING Never work around any raised implement while in the raised position without using safety lockups.

ANHYDROUS AMMONIA SAFETY

(Source: Pennsylvania State University. Agricultural Safety and Health)

ANHYDROUS AMMONIA (NH₃) is a nitrogen crop fertilizer that can cause severe chemical burns; frostbite to the eyes, skin, and respiratory tract; and death. It is important for all individuals working with this type of fertilizer to understand the potential risks, necessary safety precautions, and proper response in the event of accidental contact.

Anhydrous ammonia is a hygroscopic compound, meaning that it takes up water from the nearest source, which can include the human body—especially the eyes, lungs, and skin because of their high moisture content. Anhydrous ammonia is caustic, corrosive, and damaging to tissue high in moisture content when it contacts the human body. Anhydrous ammonia inhalation incidents are typically severe because the victim's throat can swell shut, causing suffocation. When vapors or liquid come in contact with a person's eyes, blindness may occur.

Typically, anhydrous ammonia is stored under pressure, but it vaporizes to a colorless gas. It has a unique odor that can be detected at a low concentration of 5 ppm. The concentration in fertilizer is approximately 1,000,000 ppm, but even brief exposure to a concentration of 2,500 to 6,500 ppm can result in death.

Anhydrous ammonia is transported under pressure as a liquid, so all equipment used for transport must be designed for use under high pressure to avoid ruptures or breaks. Incidents can occur when anhydrous ammonia escapes from transfer hoses or valves, equipment malfunctions and sprays anhydrous ammonia in multiple directions, hoses pull apart during transportation or application, and so on.

PPE AND SUPPLIES

It is essential that all workers who use anhydrous ammonia wear the appropriate personal protective equipment (PPE), be equipped with necessary response supplies, and know how to respond in an emergency. PPE should include ventless goggles or a full-face shield, rubber gloves with long cuffs that can be rolled to catch drips, and a long-sleeved shirt. Non-rubber gloves made of ammonia-proof material are acceptable. Because contact lenses can trap the gas and become fused to the eye, it is recommended that individuals not wear contact lenses while working with anhydrous ammonia.

In the event of an exposure emergency, the most important resource is an ample supply of clean water to begin flushing the eyes and skin. If you use a vehicle to transport anhydrous ammonia, you must carry a 5 gal. container of clean water. Each person working with anhydrous ammonia should carry a 6 to 8 fl. oz. squeeze bottle of water at all times for rapid response to an emergency.

BASIC FIRST AID FOR ANHYDROUS AMMONIA EXPOSURE

The first-response treatment for anhydrous ammonia exposure is to flush the exposed area (skin, nose, throat, eyes, and so on) with clean water for a minimum of 15 minutes.

- Flush the exposed area immediately to decrease injury caused by the anhydrous ammonia coming in contact with skin or clothes. Although clean water is the ideal resource for flushing exposed areas of the body, if you do not have water available, other nontoxic liquids, such as cold coffee or orange juice, can be used.
- Remove contaminated clothing unless the clothing is frozen to the victim's skin.
- Seek medical attention immediately and inform medical staff of the exposure to anhydrous ammonia so that they will not treat the wounds with oils or ointments that can intensify the damage.

If you find a person who is in a continuous stream of anhydrous ammonia, contact your local emergency service responders or 911. Inform the emergency medical responders about the type of incident so they can bring the proper equipment to the scene. A self-contained breathing apparatus (SCBA) and protective clothing are necessary to remove a person from a continuous stream. Rescue workers will contact a hazardous materials (HAZMAT) disposal team if HAZMAT services are needed at the scene.

Note that these guidelines are not comprehensive, and all individuals working with anhydrous ammonia should receive training in the proper response to exposure emergencies.

Storage and Transportation

Anhydrous ammonia is a strong alkali that, when dissolved in water, readily reacts with copper, zinc, brass, and other alloys. Therefore, the only types of containers, fittings, and piping that should come in contact with anhydrous ammonia should be non-galvanized steel or iron. Do not store other materials, such as propane or liquefied petroleum gas, in a tank that has been used to store anhydrous ammonia.

When filling your anhydrous ammonia tank, do not fill it more than 85% full, and always disconnect the fill hose before moving the tank. Remember to bleed pressurized anhydrous ammonia from the hose before connecting or disconnecting the hose.

When transporting anhydrous ammonia, be sure to adhere to the following precautions and safety rules:

- **Running Gear:** Regularly inspect the wagon's frame tongue, reach poles, anchor devices, wheel bearings, knuckles, ball joints, and pins for structural damage and wear and make necessary repairs and adjustments.
- **Tires:** Check tires for proper inflation, bald spots, and signs of wear and ensure that lug nuts are tight.
- **Hoses and Valves:** Inspect and replace hoses and valves as needed.
 - o The hydrostatic relief valve should be replaced every five years.
 - o The transfer hose should be replaced five years from the date of manufacture.

- **Lubrication:** Annually lubricate the wagon's knuckle, wheels, tongues, and so on.
- **Tow Vehicle:** To increase the driver's ability to control the towing vehicle, ensure that the towing vehicle weighs at least as much as the tank.
 - o A tractor can tow two tanks, but a truck can tow only one tank at a time.
- **Speed Limit:** When towing an anhydrous ammonia tank, observe a speed limit of 25 mph.
- **Hitch Pin:** Use a hitch pin with a safety chain when towing a tank wagon.
- **Warning Lights:** Ensure that the tank is equipped with a seven-terminal breakaway connector plug to properly operate turn signals, flashing warning lights, and a red brake light.
- **Safety Signage:** If operating on a highway, outfit the tank with all required safety markings, including a slow-moving vehicle (SMV) sign.
 - o The words *Anhydrous Ammonia* must appear on both sides of the tank and on the rear of the tank in letters 4 in. high. The words should be in contrast to the tank so that they can be read easily.
 - o *Inhalation Hazard* must appear on both sides of the tank in letters 3 in. high.
 - o A Department of Transportation (DOT) placard number 1005 for nonflammable gas should be placed on the front, back, and sides of the tank.

Additional Safety Recommendations

- Paint the tank with reflective white paint to decrease excessive pressure buildup that can occur when the tank is heated from direct sunlight.
- Do not use dented or damaged tanks until they have been checked by an authorized inspector and necessary repairs are completed.
- Allow only certified welders to perform welding on the tank.
- Regulations and codes regarding towing of anhydrous ammonia and signage may vary, so be familiar with and obey the regulations in your state.

Summarized by:

Linda M. Fetzer, Pennsylvania State University – lmf8@psu.edu

Reviews:

LaMar Grafft, University of Iowa – lamar-grafft@uiowa.edu

Dennis J. Murphy, Pennsylvania State University – djm13@psu.edu

J. Samuel Steel, Pennsylvania State University – jss13@psu.edu

Aaron M. Yoder, University of Nebraska Medical Center - aaron.yoder@unmc.edu

Use the following format to cite this article:

Anhydrous ammonia safety. (2012) Farm and Ranch eXtension in Safety and Health (FReSH) Community of Practice. Retrieved from <http://www.extension.org/pages/63196/anhydrous-ammonia-safety>.

Schwab, C., Hanna, M., & Miller, L. (2008) Anhydrous ammonia safety: Play it safe with anhydrous ammonia. Iowa State University Extension and Outreach. Retrieved from <https://store.extension.iastate.edu/ItemDetail.aspx?ProductID=4989>.

Training module: Safe handling of anhydrous ammonia (NH₃). (2002) Ohio State University Extension. Retrieved from <http://nasdonline.org/1731/d001719/safe-handling-of-anhydrous-ammonia-nh....>

Training module: Towing anhydrous ammonia tanks. (2002) Ohio State University Extension Agricultural Tailgate Safety Training. Retrieved from <http://nasdonline.org/1794/d001750/towing-anhydrous-ammonia-tanks.html>

FIRST AID

Decontaminate the victim as quickly as possible. Start with the eyes. The whole body, or exposed area, must be flushed with generous amounts of water; this includes the hair, ears, under the chin, and armpits. Water sources such as showers, hoses, eye wash stations, or stock tanks are acceptable [29 CFR 1910.151(c)]

Ensure trained personnel and adequate first aid supplies are readily available [29 CFR 1910.151(b)]



Eyewash Station

CONTACT WITH THE EYES

Even if only a small amount of ammonia enters the eyes, irrigate the eyes with an abundance of water for a minimum of 15 minutes. Continually and thoroughly flush the entire eye surface and the inner lining of the eyelids. Eyes affected by ammonia close involuntarily, so the eyelids must be held open so that water can flush the entire eye surface, as well as the inner lining of the eyelid.

If there is no physician available, continue irrigation for an additional 15 minutes.

Do not wear contact lenses when handling anhydrous ammonia. If ammonia gets in the eyes, the ammonia will get trapped under the lenses causing even more damage. They may also prevent immediate flushing of the eye surface.

Serious eye injury should be treated by an ophthalmologist, but in an emergency, wash with large quantities of water for 15 minutes or more as quickly as possible. In fact, the only real hope for preventing permanent eye injury lies in quick and generous washing.

One suggestion for those likely to be exposed is to carry a small, eight-ounce squeezable squirt bottle filled with water, which can be used to get excess ammonia out of the eyes until a larger water supply can be reached. This small amount of water is not sufficient to remove all the ammonia. It is essential that the eyes be irrigated for a minimum of 15 minutes as soon as possible.



Squirt Bottle

Another emergency method is to duck the head in water and rapidly blink and move or rotate the eyes about.

CONTACT WITH THE SKIN

It is essential that any ammonia spilled on the worker be removed immediately and that the worker be moved to an uncontaminated area quickly.

Clothes that have been saturated by liquid ammonia may freeze to the skin. In any case, the victim, still clothed, should get immediately under a shower, if available, or jump into a stock tank, pond, or into any other source of water. Time is important! Remove clothes only after they are thawed and they can be freely removed from frozen areas. If the clothing is removed incorrectly, whole sections of skin can be torn off.

No salves, creams, ointments, or jellies should be applied to the skin during a 24-hour period following the injury since this will prevent natural elimination of the ammonia from the skin. After the 24 hour period, the medical treatment is the same for thermal burns. A physician should view any second- or third-degree freeze burns of the skin.

TAKEN INTERNALLY: This is what you should do if ammonia is ingested:

- Call a physician.
- If conscious, have the victim drink large amounts of water.
- Do not induce vomiting if the victim is in shock, in extreme pain, or is unconscious.
- If vomiting begins, place the victims face down with head lower than hips. This prevents vomit from entering the lungs and prevents severe injury.

Inhalation

In all inhalation exposures, severe or minimal:

- Take the exposed workers at once to a clean, uncontaminated area.
- Watch workers exposed to low concentrations for a short period of time. They will usually require no treatment and can be released.
- For severe exposure to higher concentrations:

Call a physician.

Administer oxygen by an individual who is trained and authorized to do so by a physician. This will help relieve pain and symptoms of lack of oxygen.

Begin artificial respiration immediately if the patient is not breathing.

Keep victim warm (but not hot) and rested until transported to the hospital.

Summary: In any accident involving contact with ammonia with the eyes or skin:

- Immediately flush the affected area with large quantities of clean water.
- Place the injured person into a container of clean water or under an emergency shower.
- Provide the injured worker with first aid treatment and call a physician at once in the case of extreme exposure. Give the physician a complete account of the incident.
- Seconds count, wash the ammonia away with water immediately.

Information from U.S. Department of Labor - OSHA

https://www.osha.gov/SLTC/etools/ammonia_refrigeration/emergency/index.html#firstaid

TABLE OF CONTENTS

New installation instruction	page 3-5
Retro fit installation instructions	page 5-7
Reconnection instructions	page 7-9
Disconnection instructions	page 9
Maintenance instructions	page 9-10

OPERATING AND INSTALLATION INSTRUCTIONS FOR THE A-HFC-114

HIGH FLOW TOOL BAR COUPLING



CAUTION  **DANGER**

PLEASE READ THIS ENTIRE MANUAL AND FOLLOW THE INSTRUCTIONS CAREFULLY. FAILURE TO READ AND FOLLOW ALL OF THE INSTRUCTIONS AND WARNINGS IN THIS MANUAL MIGHT RESULT IN A DANGEROUS RELEASE OF ANHYDROUS AMMONIA AND CAUSE SERIOUS BODILY INJURY.



CAUTION **DANGER**

ALLWAYS FOLLOW MANUFACTURES INSTRUCTIONS WHEN INSTALLING, DISCONNECTING OR RECONNECTING THE QUICK COUPLING. FAILURE TO DO SO MAY CAUSE BODILY INJURY.

ALWAYS FOLLOW STEPS 1-3 BELOW BEFORE PERFORMING MAINTENANCE, INSTALLATION, RECONNECTING OR DISCONNECTING THE QUICK COUPLING

1. ALLWAYS WEAR GOGGLES AND GLOVES AND HAVE EMERGENCY WATER AVAILABLE.
2. CLOSE ALL VALVES.
3. OPEN ALL BLEED VALVES AND DRAIN ALL OF THE AMMONIA FROM THE HOSES ATTACHED TO THE TANK AND THE APPLICATOR. ALWAYS BE CAREFUL WHEN OPENING A BLEED VALVE TO MAKE SURE THE OUTLET IS POINTING IN A SAFE DIRECTION AND AWAY FROM YOU OR ANYONE ELSE. DO NOT PROCEED UNTIL YOU HAVE MADE SURE ALL OF THE AMMONIA HAS BEEN DRAINED FROM ALL OF THE HOSES.

NEW INSTALLATION INSTRUCTIONS

1. ALWAYS WEAR GOGGLES AND GLOVES AND HAVE EMERGENCY WATER AVAILABLE.
2. CLOSE ALL VALVES.
3. OPEN ALL BLEED VALVES AND DRAIN ALL OF THE AMMONIA FROM THE HOSES ATTACHED TO THE TANK AND THE APPLICATOR. **ALWAYS BE CAREFUL WHEN OPENING A BLEED VALVE TO MAKE SURE THE OUTLET IS POINTING IN A SAFE DIRECTION AND AWAY FROM YOU OR ANYONE ELSE. DO NOT PROCEED UNTIL YOU HAVE MADE SURE ALL OF THE AMMONIA HAS BEEN DRAINED FROM ALL OF THE HOSES.**
4. ATTACH THE MOUNTING CLAMP ON TO THE TOOL BAR BY DRILLING TWO 17/32 INCH HOLES ON 2" CENTERS. MAKE SURE IT IS MOUNTED ONTO A PORTION OF THE TOOL BAR THAT IS ATLEAST 1/4" THICK. ATTACH THE TWO 1/2" BOLTS AND NUTS SECURELY TO THE CLAMP AND TOOL BAR AND TIGHTEN FIRMLY. THE FEMALE SIDE OF THE COUPLING WILL ALREADY BE ATTACHED TO THE MOUNTING BRACKET BUT MAKE SURE THE COUPLING IS INSTALLED ON THE CORRECT SIDE OF THE BRACKET AS SHOWN IN THE PHOTO BELOW.

NOTE BRACKET ORIENTATION TOOL BAR

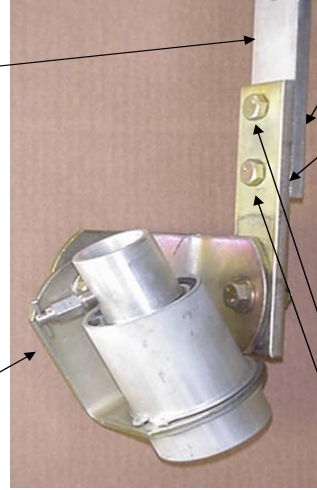

ATTACH THE TWO 1/2" BOLTS AND NUTS DRILL TWO 17/32 INCH HOLES

MAKE SURE YOU HAVE AT LEAST 18" OF SLACK IN THE SECTION OF HOSE CONNECTING THE A-HFC-114 TO THE APPLICATION EQUIPMENT MOUNTED ON THE TOOL BAR TO ALLOW SUFFICIENT ARTICULATION OF THE UNIT.

5. SCREW THE APPLICATOR HOSE INTO THE FEMALE END OF THE COUPLING AND MAKE SURE TO USE PIPE THREAD SEALANT AS SHOWN IN THE PHOTO BELOW

HOSE TO METERING DEVICE

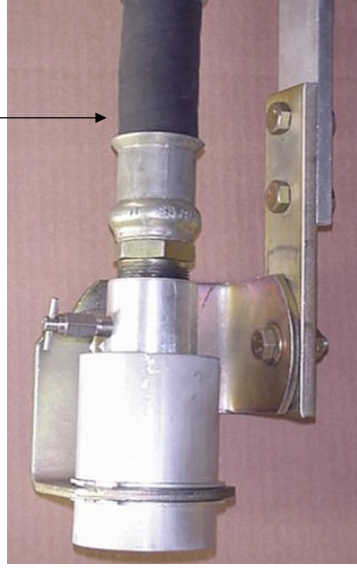

6. IF YOUR SUPPLY HOSE IS ATTACHED TO THE NURSE TANK, SCREW AN ACME ADAPTOR INTO THE 1-1/4" FNPT OF THE MALE END OF THE COUPLING. MAKE SURE TO USE PIPE THREAD SEALANT AS SHOWN IN THE PHOTO BELOW



7. IF YOUR SUPPLY HOSE IS ATTACHED TO THE TOOL BAR THEN SCREW THE SUPPLY HOSE INTO THE 1-1/4" FNPT SIDE OF THE MALE END OF THE COUPLING. AS SHOWN IN THE PHOTO BELOW.



8. ATTACH THE OPERATING INSTRUCTION DECAL TO THE TOOL BAR AS CLOSE TO THE A-HFC-114 AS POSSIBLE

9. FOR CONNECTING THE MALE AND FEMALE ENDS OF THE COUPLING TOGETHER SEE THE "RECONNECTION INSTRUCTIONS" SECTION BELOW.

RETRO-FIT INSTALLATION INSTRUCTIONS

1. ALWAYS WEAR GOGGLES AND GLOVES AND HAVE EMERGENCY WATER AVAILABLE.
2. CLOSE ALL VALVES.
3. OPEN ALL BLEED VALVES AND DRAIN ALL OF THE AMMONIA FROM THE HOSES ATTACHED TO THE TANK AND THE APPLICATOR. **ALWAYS BE CAREFUL WHEN OPENING A BLEED VALVE TO MAKE SURE THE OUTLET IS POINTING IN A SAFE DIRECTION AND AWAY FROM YOU OR ANYONE ELSE. DO NOT PROCEED UNTIL YOU HAVE MADE SURE ALL OF THE AMMONIA HAS BEEN DRAINED FROM ALL OF THE HOSES.**
4. REMOVE THE OLD COUPLING AND THE LAST "L" SHAPED BRACKET FROM THE UNIT AS SHOWN IN THE PHOTO BELOW.



5. THERE ARE 2 DIFFERENT SIZE BRACKETS THAT PIONEER HAS USED WITH THEIR COUPLING. THE OLDER BRACKET HAS A 1/2" BOLT HOLE AND THE NEWER ONE HAS A 3/4" BOLT HOLE. AS SHOWN IN THE PHOTO BELOW.

SMALL 1/2" BOLT HOLE BRACKET



BIG 3/4" BOLT HOLE BRACKET

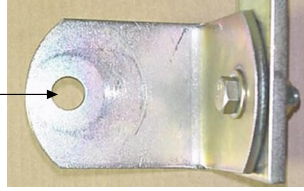

6. IF YOU HAVE THE 1/2" BOLT HOLE BRACKET USE THE SHORT BUSHING, IF YOU HAVE THE 3/4" BOLT HOLE BRACKET USE THE LONG BUSHING AS SHOWN IN THE PHOTO BELOW.

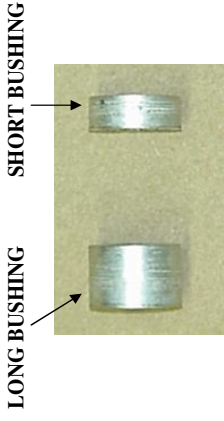

7. ATTACH THE BRACKET WITH THE 1/2" BOLT, WASHERS AND NUT WITH THE CORRECT BUSHING AS SHOWN IN THE PHOTO BELOW AND TIGHTEN FRIMLY. MAKE SURE YOU PUT THE BUSHING ON THE COUPLER BRACKET NOT THE MIDDLE BRACKET AS SHOWN IN THE PHOTO.

BUSHING ON COUPLING BRACKET

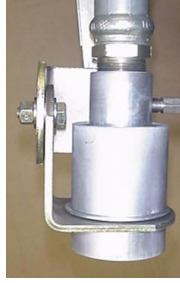
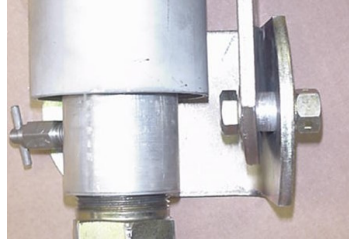
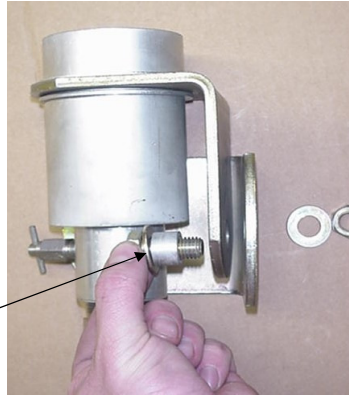

8. ******IMPORTANT****** MAKE SURE THE BRACKET SWIVELS UP AND DOWN AND SIDE TO SIDE 80 DEGREES TO EACH SIDE OF CENTER LINE. THERE SHALL BE NOTHING OBSTRUCTING THE SWIVEL FEATURE OF THIS UNIT. DO NOT INSTALL ANY APPARATUS; HOSE SUPPORT ANYTHING ELSE THAT WILL IMPEDE THE MOVEMENT OF THE BREAKAWAY. THIS IS VERY IMPORTANT. IF IT DOES NOT SWIVEL UP AND DOWN AND SIDE TO SIDE THEN IT WILL NOT FUNCTION PROPERLY.
9. AFTER YOU HAVE INSTALLED YOUR NEW COUPLING SEE THE "RECONNECTION INSTRUCTIONS" SECTION ABOVE TO CONNECT THE MALE END.

RECONNECTION INSTRUCTIONS

1. ALWAYS WEAR GOGGLES AND GLOVES AND HAVE EMERGENCY WATER AVAILABLE.
2. CLOSE ALL VALVES.
3. OPEN ALL BLEED VALVES AND DRAIN ALL OF THE AMMONIA FROM THE HOSES ATTACHED TO THE TANK AND THE APPLICATOR. ALWAYS BE CAREFUL WHEN OPENING A BLEED VALVE TO MAKE SURE THE OUTLET IS POINTING IN A SAFE DIRECTION AND AWAY FROM YOU OR ANYONE ELSE. DO NOT PROCEED UNTIL YOU HAVE MADE SURE ALL OF THE AMMONIA HAS BEEN DRAINED FROM ALL OF THE HOSES.
4. INSPECT THE ORINGS TO MAKE SURE THEY ARE IN GOOD CONDITION. NEVER LOOK DIRECTLY INTO THE OPENING OF THE MALE OR FEMALE SIDE OF THE QUICK COUPLING. HOLD IT AT AN ANGLE AWAY FROM YOU TO DO THE INSPECTION SO IF ANY AMMONIA IS LEFT IN THE HOSE IT WILL NOT SPRAY ON YOU OR ANYONE ELSE. GREASE O-RINGS IF NECESSARY. SEE PHOTO BELOW



5. SLOWLY INSERT THE MALE END OF THE QUICK COUPLING THAT IS ATTACHED TO THE NURSE TANK HOSE INTO THE FEMALE END OF THE QUICK COUPLING THAT IS ATTACHED TO THE APPLICATOR. IT HELPS SOMETIMES TO TWIST THE MALE END WHEN INSERTING IT TO GET THE MALE TIP PAST THE ORINGS. THEN HOLD THE BRACKET ON THE FEMALE END FIRMLY WITH ONE HAND AND PUSH THE MALE END IN FIRMLY WITH THE OTHER HAND SO IT IS COMPLETELY ATTACHED BY CHECKING TO MAKE SURE THE LOCKING SHOULDER ON THE MALE END IS FULLY INSERTED INTO THE FEMALE END OF THE COUPLING. SEE PHOTO BELOW.

NOT INSTALLED CORRECTLY

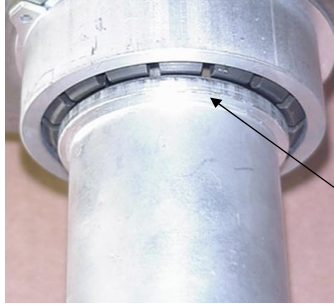

LOCKING SHOULDER NOT INSERTED

INSTALLED CORRECTLY

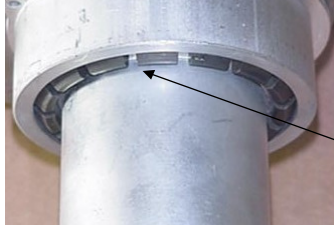

LOCKING SHOULDER INSERTED

LOCKING SHOULDER

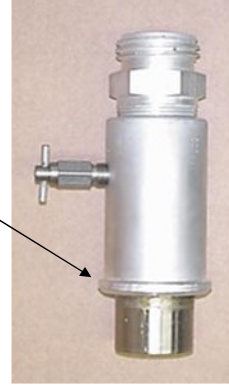

COMPLETELY INSTALLED UNIT

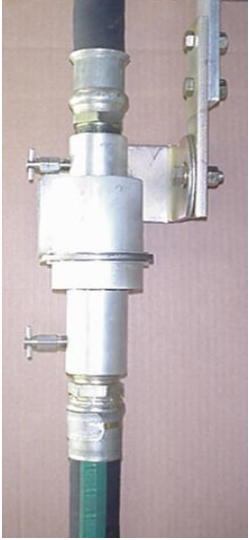

6. SHAKE HOSE TO MAKE SURE IT IS SECURELY ATTACHED.
7. CLOSE ALL BLEED VALVES

DISCONNECTION INSTRUCTIONS

1. ALWAYS WEAR GOGGLES AND GLOVES AND HAVE EMERGENCY WATER AVAILABLE.
2. CLOSE ALL VALVES.
3. OPEN ALL BLEED VALVES AND DRAIN ALL OF THE AMMONIA FROM THE HOSES ATTACHED TO THE TANK AND THE APPLICATOR. **ALWAYS BE CAREFUL WHEN OPENING A BLEED VALVE TO MAKE SURE THE OUTLET IS POINTING IN A SAFE DIRECTION AND AWAY FROM YOU OR ANYONE ELSE. DO NOT PROCEED UNTIL YOU HAVE MADE SURE ALL OF THE AMMONIA HAS BEEN DRAINED FROM ALL OF THE HOSES.**
4. PULL THE NURSE TANK HOSE FIRMLY TO DISCONNECT THE MALE END OF THE QUICK COUPLING FROM THE FEMALE END.

MAINTENANCE INSTRUCTIONS

1. ALWAYS WEAR GOGGLES AND GLOVES AND HAVE EMERGENCY WATER AVAILABLE.
2. CLOSE ALL VALVES.
3. OPEN ALL BLEED VALVES AND DRAIN ALL OF THE AMMONIA FROM THE HOSES ATTACHED TO THE TANK AND THE APPLICATOR. **ALWAYS BE CAREFUL WHEN OPENING A BLEED VALVE TO MAKE SURE THE OUTLET IS POINTING IN A SAFE DIRECTION AND AWAY FROM YOU OR ANYONE ELSE. DO NOT PROCEED UNTIL YOU HAVE MADE SURE ALL OF THE AMMONIA HAS BEEN DRAINED FROM ALL OF THE HOSES.**
4. PULL THE NURSE TANK HOSE FIRMLY TO DISCONNECT THE MALE END OF THE QUICK COUPLING FROM THE FEMALE END.
5. REMOVE THE HOSES FROM BOTH THE FEMALE END AND MALE END OF THE QUICK COUPLING SO THAT THE QUICK COUPLING IS NOT CONNECTED TO ANY HOSES.
6. INSPECT THE 2 O-RINGS IN THE FEMALE SIDE OF THE COUPLING FOR CUTS OR PITS IN THE O-RING. REPLACE THEM IF THERE ARE ANY CUTS OR PITS OR SEAM TO BE DRYED OUT OR AGING. IF THEY ARE IN GOOD SHAPE APPLY SOME GREASE TO THEM TO ENSURE THEY REMAIN IN GOOD CONDITION. **NEVER LOOK DIRECTLY**

INTO THE OPENING OF THE MALE OR FEMALE SIDE OF THE QUICK COUPLING. HOLD IT AT AN ANGLE AWAY FROM YOU TO DO THE INSPECTION SO IF ANY AMMONIA IS LEFT IN THE COUPLING IT WILL NOT SPRAY ON YOU OR ANYONE ELSE.

7. INSPECT THE CHECK VALVES IN THE MALE AND FEMALE ENDS OF THE QUICK COUPLING BY PRESSING IN ON THE CHECK VALVE WITH YOUR THUMB TO MAKE SURE THEY MOVE IN AND OUT FREELY.
8. CLEAN ANY DIRT OR DEBRIS THAT YOU FIND IN EITHER END OF THE COUPLING.
9. SPIN THE LOCKING COLLET IN THE FEMALE END OF THE QUICK COUPLING WITH YOUR FINGER TO MAKE SURE IT MOVES FREELY. USE WD-40 OR A SIMILAR PRODUCT IF NECESSARY TO GET IT TO MOVE FREELY.
10. RECONNECT THE HOSES THAT WERE REMOVED AND FOLLOW THE “RECONNECTION INSTRUCTIONS” SECTION ABOVE TO RECONNECT THE QUICK COUPLING.

**IF YOU HAVE ANY QUESTIONS PLEASE CALL US AT
800-537-5642**

CYLINDER OPERATING INSTRUCTIONS

Wing Fold Cylinder - Float Position

Wheel Lift Cylinders - Standard Position

*** Failure to operate cylinders in the correct position may cause damage to the cylinders**

PURGING INSTRUCTIONS FOR REPHASING CYLINDERS

- To properly purge air from the system, cylinders should be fully extended to the rephasing mode.
- Hold the cylinders in the fully extended mode for approximately 30 seconds, retract the cylinders and repeat until all air is purged from the system. Make sure the tractor RPM is moderate so the hydraulic pump is at its full capacity.
- Initial system start-up should be done with the rod end of the cylinders unpinned, making sure to support the rod and watch that the rod will not interfere with any framework or other objects. During initial start-up, the seals may need a few cycles to seat themselves for a good seal.
- Patience is the key and air is the worst enemy. Never loosen a fitting to bleed off the system. This can be dangerous.
- To maintain the rephasing system during normal operating, the cylinders should always be cycled to the full extent of their stroke each time they are operated.

BULL PULL TONGUE & HOSE STAND ASSEMBLY

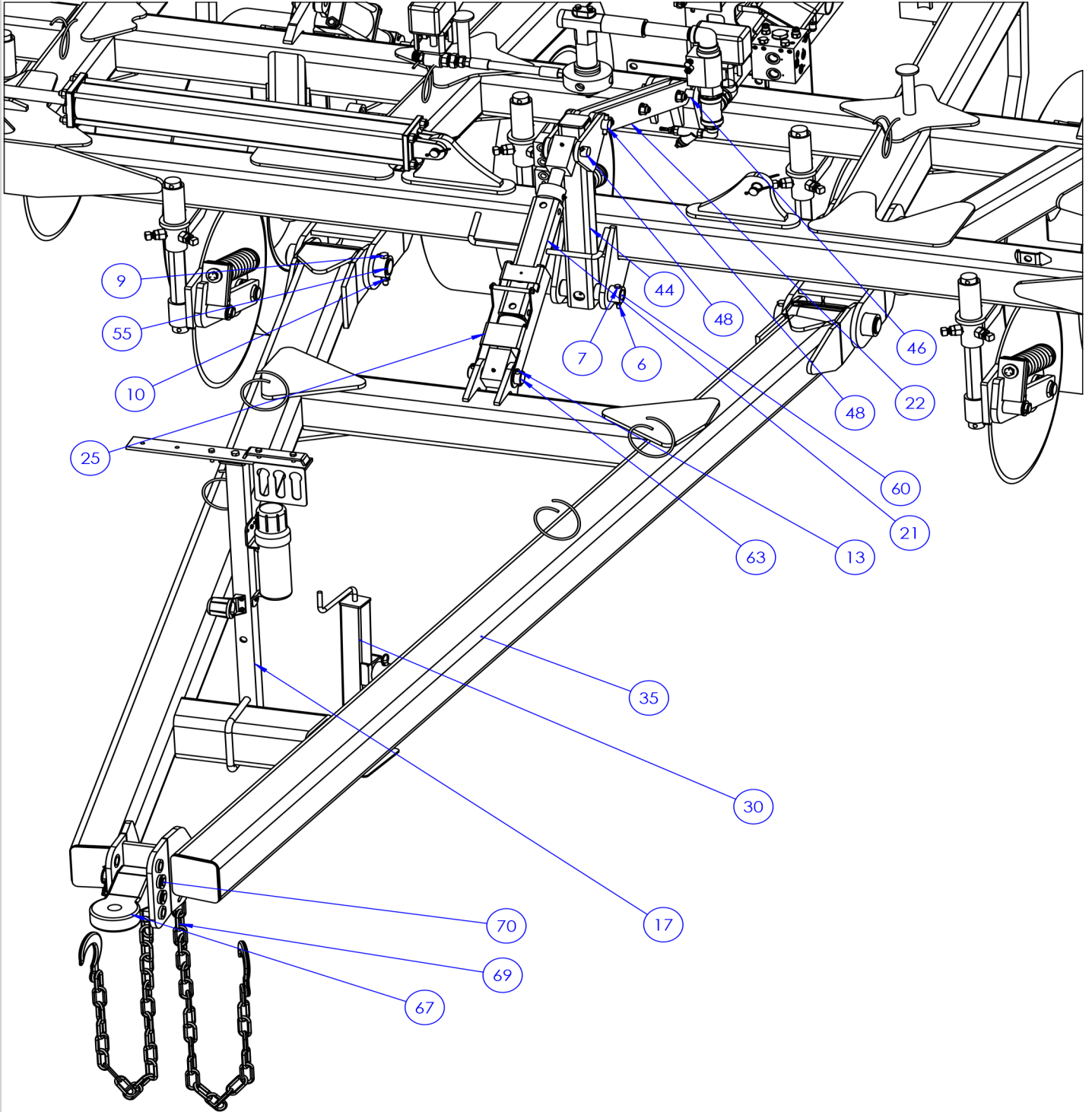

DRAWN BY	--	9/1/2020
CHECKED BY		
PRINT DATE		9/9/2024
CONFIG.	UNFOLDED	
COMMENTS:		



PROPRIETARY AND CONFIDENTIAL
 THE INFORMATION CONTAINED IN THIS DRAWING IS THE SOLE PROPERTY OF DALTON AG. ANY REPRODUCTION IN PART OR AS A WHOLE WITHOUT THE WRITTEN PERMISSION OF DALTON AG IS PROHIBITED.

DWG:	TR_TONGUE ASSY		
SIZE	SHEET TITLE:		REV
A	Sheet1		A
SCALE: 1:16	SHEET 1 OF 2		

FOR PARTS, CALL 1.800.342.7498

BULL PULL TONGUE & HOSE STAND ASSEMBLY

ITEM NO.	PART NUMBER	DESCRIPTION
6	150022	NUT, .375, LOCKING, PLTD
7	151816	BOLT, .375 X 3 NC, G8, PLTD
9	152301	BOLT .5625 X 4 NF GRD 8 PLN
10	158073	NUT, .5625 NC, CENTERLOCK, PLTD
12	158263	WASHER, 2, MC GR 8, PLATED
13	158292	ROLL PIN .4375 X 2.5 ZINC PLATED
17	4410175	HOSE STAND
21	4410818	ADJUSTABLE LINK
22	4410820	LINK, TONGUE SUPPORT
25	4410829	LOCK ASSEM. ADJUSTABLE LINK 1.625
30	4420862	DROP FOOT JACK
35	4421642	HITCH, BP TRIPPLE RANK TOOLBAR
44	4421664	WELDMNT, ROCKER ARM, TONGUE ADJUSTMENT
46	4421670	PIN, 1.00 X 6.375, HEADED
48	4421673	PIN, 1.25 X 4.09, HEADED
55	4431299	PIN, 2 X 10.875, HEADLESS
60	4434172	PIN, 1.25 X 8.375, HEADLESS
63	4435915	PIN 1.625 X 4.688 HEADLESS
66	4440887	COMPOSITE BUSHING
67	4440918	BULL PULL CAT 4
69	4441023	4441023, 50 INCH CHAIN LINK
70	4441048	CLEVIS PIN

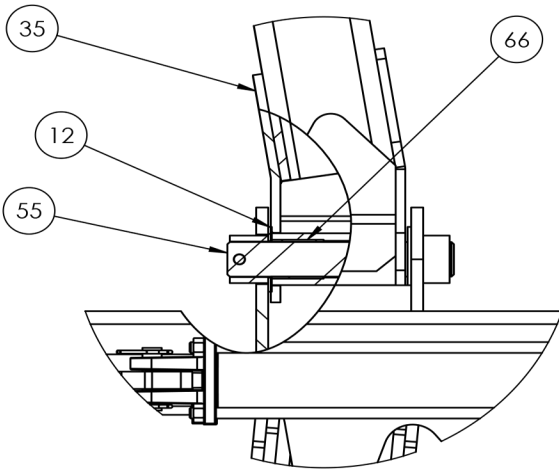

DRAWN BY	--	9/1/2020
CHECKED BY		
PRINT DATE		9/9/2024
CONFIG.	UNFOLDED	



PROPRIETARY AND CONFIDENTIAL
 THE INFORMATION CONTAINED IN THIS DRAWING IS THE SOLE PROPERTY OF DALTON AG. ANY REPRODUCTION IN PART OR AS A WHOLE WITHOUT THE WRITTEN PERMISSION OF DALTON AG IS PROHIBITED.

COMMENTS:

DWG:	TR_TONGUE ASSY		
SIZE	SHEET TITLE:	Sheet2	REV
A			A
SCALE: 1:16	SHEET 2 OF 2		

FOR PARTS, CALL 1.800.342.7498

TOOLBAR WHEEL LIFT CYLINDER LAYOUT

TOOLBAR WHEEL LIFT CYLINDER LAYOUT

NOTE: ORIENTATION OF "LEFT" AND "RIGHT" IS DEFINED AS YOUR VIEW WHEN STANDING BEHIND THE TOOLBAR

NOTE: HOSE LOCATIONS ARE IDENTIFIED BY A LETTER WITHIN A BOX, I.E. A

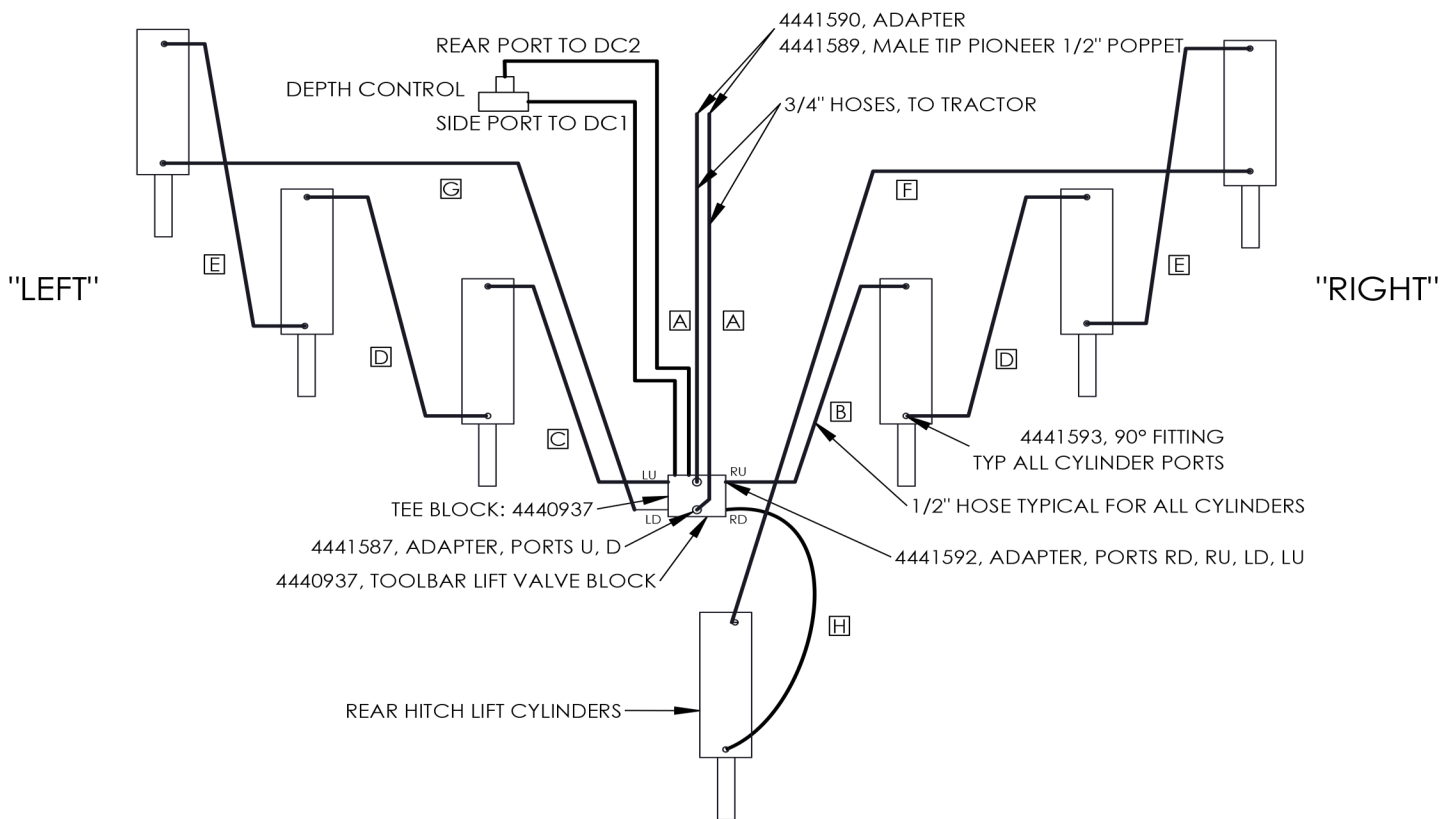

DRAWN BY	RICH SMOTHERS
CHECKED BY	
PRINT DATE	
CONFIG.	



PROPRIETARY AND CONFIDENTIAL
THE INFORMATION CONTAINED IN THIS DRAWING IS THE SOLE PROPERTY OF DALTON AG. ANY REPRODUCTION IN PART OR AS A WHOLE WITHOUT THE WRITTEN PERMISSION OF DALTON AG IS PROHIBITED.

COMMENTS:

DWG:		
TOOLBAR HYDRAULICS - TRIPLE RANK - LIFT CYLINDERS		
SIZE	SHEET TITLE:	REV
A	Sheet1	A
SCALE: 1:12		SHEET 1 OF 1

TOOLBAR WING CYLINDER LAYOUT

TOOLBAR WING CYLINDER LAYOUT

NOTE: ORIENTATION OF "LEFT" AND "RIGHT" IS DEFINED AS YOUR VIEW WHEN STANDING BEHIND THE TOOLBAR
NOTE: HOSE LOCATIONS ARE IDENTIFIED BY A LETTER WITHIN A BOX, I.E. [A]

SEQUENCE VALVE
SEE 4410831 FOR
CONNECTIONS

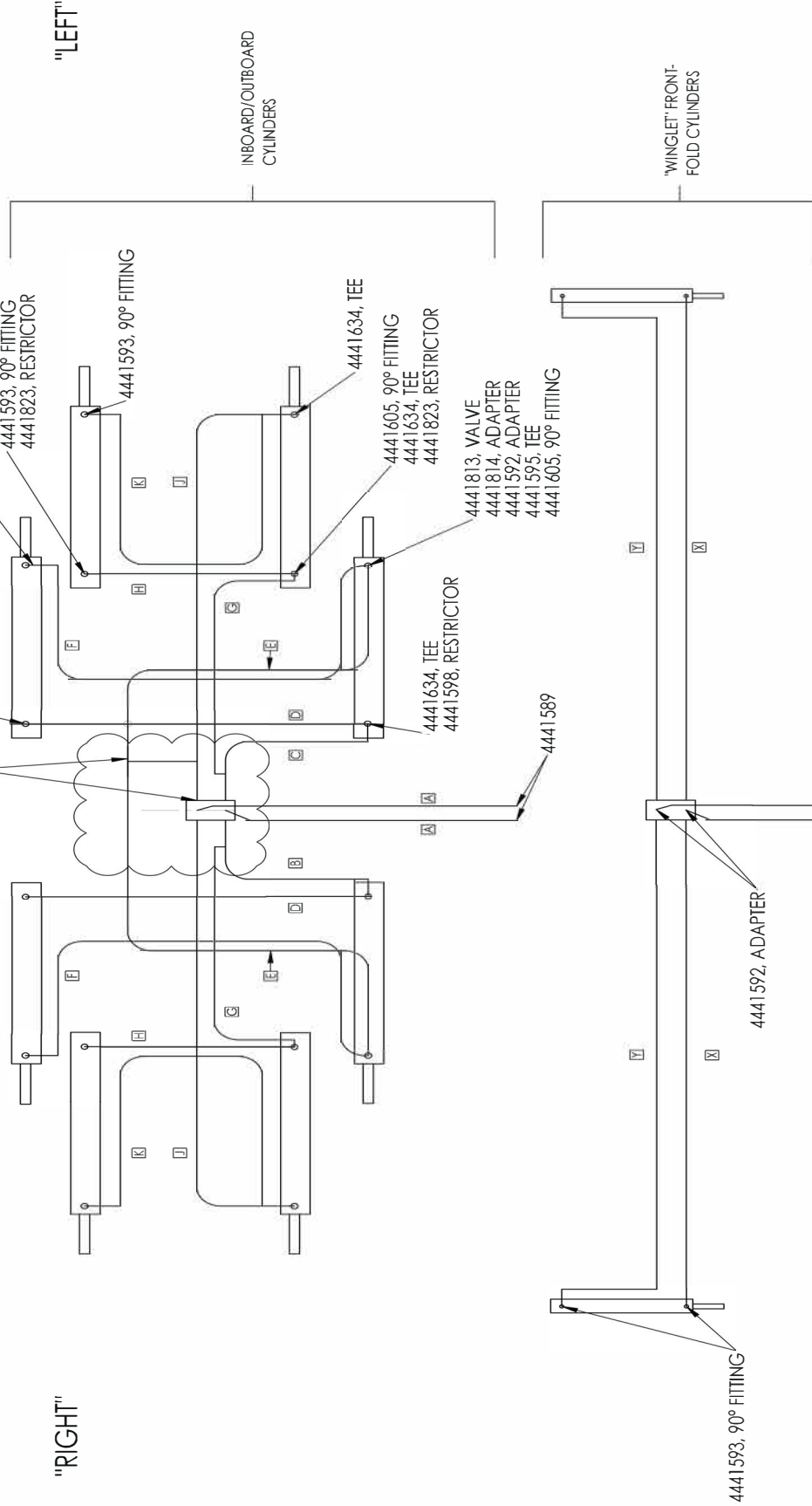

 <p>402 E. VAN BUREN ST., LENOX, IA 50551</p>		DRAWN BY: Donald Sundberg DATE: 1/19/2021 FILE: TOOLBAR HYDRAULICS - TRIPPLE RANK - WING CONFIG: CH010101 PRINT DATE: 12/17/2024 MATERIAL: COMMENTS:	TITLE: 4400452 TR52-66 20K TRIPPLE RANK TOOLBAR
UNLESS OTHERWISE SPECIFIED TOLERANCES TO BE: ANGLES: ± 1° FRACTIONS OF INCHES: XXX: ± 0.005 XXXX: ± 0.005 THE INFORMATION CONTAINED IN THIS DRAWING IS THE SOLE PROPERTY OF DALTON AG. ANY REPRODUCTION IN PART OR AS A WHOLE WITHOUT THE WRITTEN PERMISSION OF DALTON AG IS PROHIBITED.	PROPERTY AND CONFIDENTIAL	SIZE DWG. NO. REV B WING LIFT HYDRAULIC LAYOUT(2) A	SCALE: 1:50 SHEET 1 OF 1

WING FOLD SEQUENCING VALVE

44110831

REV.	DESCRIPTION	DATE	APPROVED
A	INITIAL RELEASE	2/23/2021	DIES
B	44411592 QTY 2 WAS QTY 1. REMOVED 44411593 AND 44411633. ADDED 44411633 12/17/2024	12/17/2024	JNJ

ITEM NO.	PART NUMBER	DESCRIPTION	QTY.
1	4440984	TEE BLOCK W/ ORIFICE	1
2	4441592	.50" SAE ORB TO .50" ORFS STR. ADAPTER	2
3	4441640	P.O. SEQUENCE VALVE 200-3000 PSI WITH VALVE BLOCK	1
4	4441595	1/2" X 1/2" X 1/2" SEAL-LOK STR. TEE FITTING P# 8 35OLO-S	2
5	4441632	1/2" STRAIGHT THREAD SWIVEL CONNECTOR ORFS SWIVEL / SAE-ORB P# 8 F650L-S	1
6	4441634	1/2" ORFS X 1/2" SAE ORB X 1/2" ORFS SEAL-LOK STR. TEE FITTING P# 8 R5OLO-S	4
7	4441642	-8 ORFSM X-8 ORFSF S X-8 ORFSM SWIVEL RUN TEE P# 8 R4LO-S	1
8	4441643	-8 ORFSM X-8 ORFSM CHECK VALVE P#DT500-MSMS-5	1
9	4441644	-8 ORFSF S X-8 ORFSF S SWIVEL UNION P# 8 H4LO-S	1
10	4441633	1/2" SWIVEL NUT ELBOW ORFS/ ORFS SWIVEL P# 8 C6LO-S	2

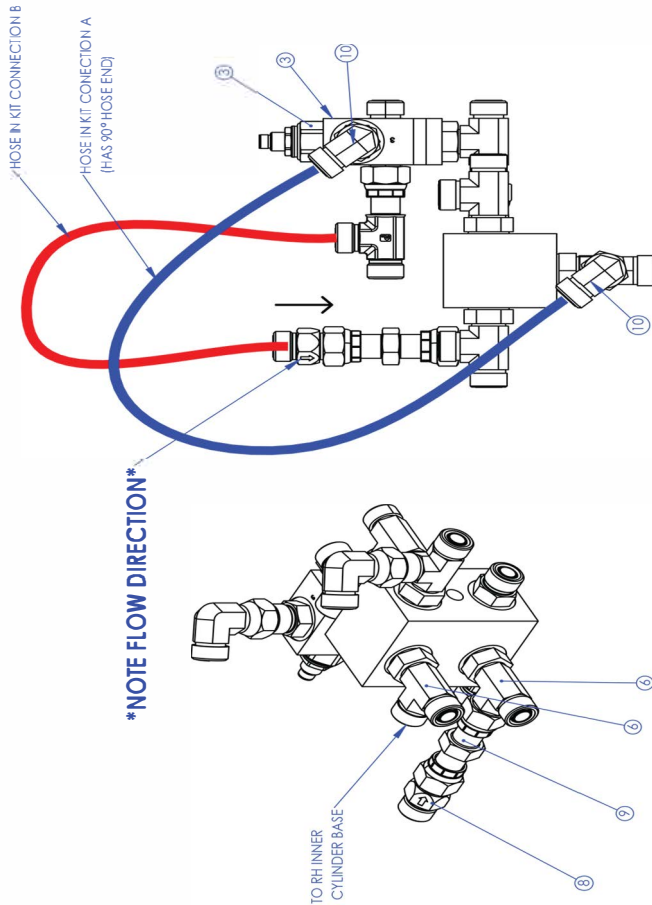

B

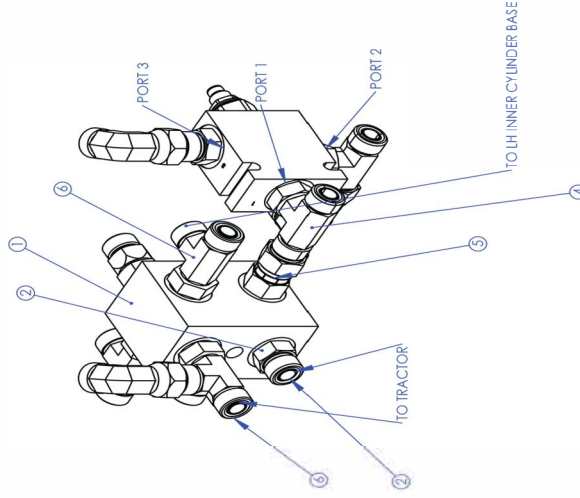

-FITTINGS ARE PROVIDED IN HOSE KIT
-SEQUENCE VALVE AND TEE BLOCK ARE PROVIDED IN HYDRAULIC PACKAGE

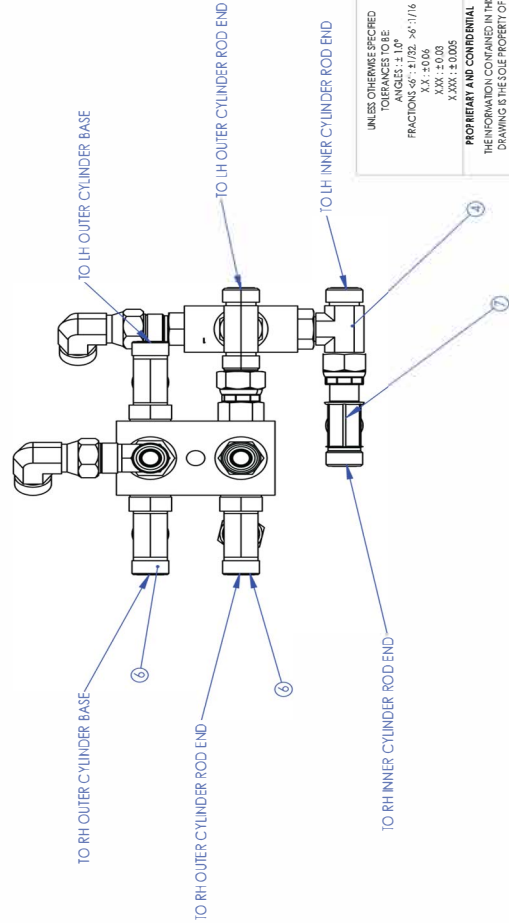

602 E. VAN BUREN ST., LEXINGTON, KY 40502

TITLE: 44110831 WING-FOLD SEQUENCING VALVE

SIZE DWG. NO. **B** Sheet1 REV **B**

SCALE: 1:4 SHEET 1 OF 1

DRAWN BY	Donald Sundberg	DATE	1/28/2021
FILE	44110831	CONFIG.	Default
PRINT DATE	12/17/2024	MATERIAL	
COMMENTS:			

UNLESS OTHERWISE SPECIFIED
TOLERANCES TO BE:
ANGLES: 1.0°
FRACTIONS: .0150, .0625, .1250
DECIMALS: .005
X.XXX: ±0.003
X.XX: ±0.003

PROPRIETARY AND CONFIDENTIAL
THE INFORMATION CONTAINED IN THIS DRAWING IS THE SOLE PROPERTY OF DALTON A.C. ANY REPRODUCTION IN PART OR AS A WHOLE WITHOUT THE WRITTEN PERMISSION OF DALTON A.C. IS PROHIBITED.

C:\L_EFDM_Vault\Hydraulics\Plumbing

TRIPLE RANK INBOARD FOLD HARDWARE

NOTE: QTY'S ARE FOR EACH CORNER OF CENTER (4 CORNERS FOR COMPLETE TOOLBAR)

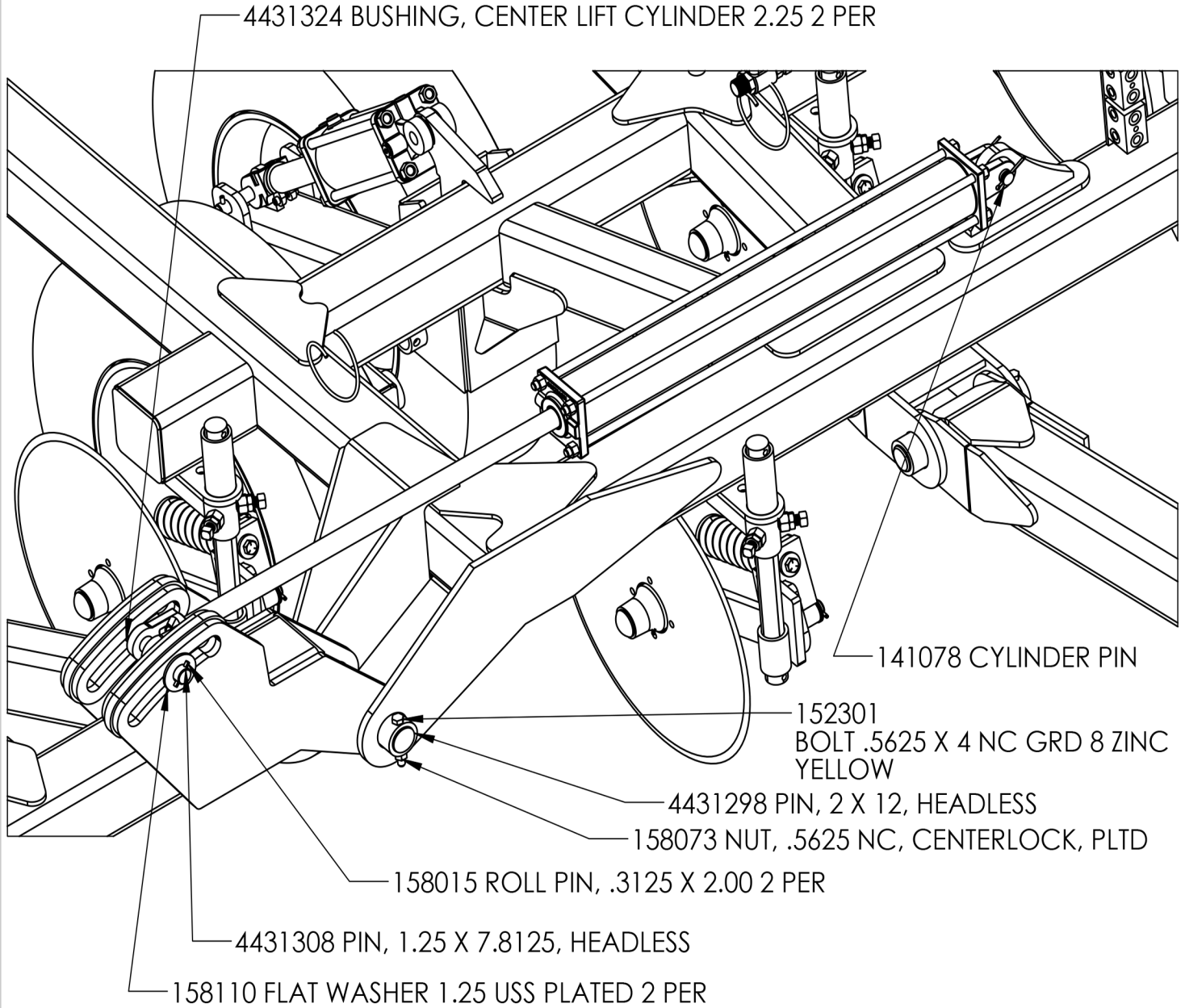

DRAWN BY	--	9/1/2020
CHECKED BY		
PRINT DATE		2/4/2025
CONFIG.	UNFOLDED	



PROPRIETARY AND CONFIDENTIAL
THE INFORMATION CONTAINED IN THIS DRAWING IS THE SOLE PROPERTY OF DALTON AG. ANY REPRODUCTION IN PART OR AS A WHOLE WITHOUT THE WRITTEN PERMISSION OF DALTON AG IS PROHIBITED.

COMMENTS:

DWG: TR INBOARD FOLD HARDWARE		
SIZE A	SHEET TITLE: Sheet1	REV A

FOR PARTS, CALL 1.800.342.7498

SCALE: 1:12 SHEET 1 OF 1

TRIPLE RANK OUTBOARD FOLD

4 OUTBOARD CYLINDERS PER TOOLBAR

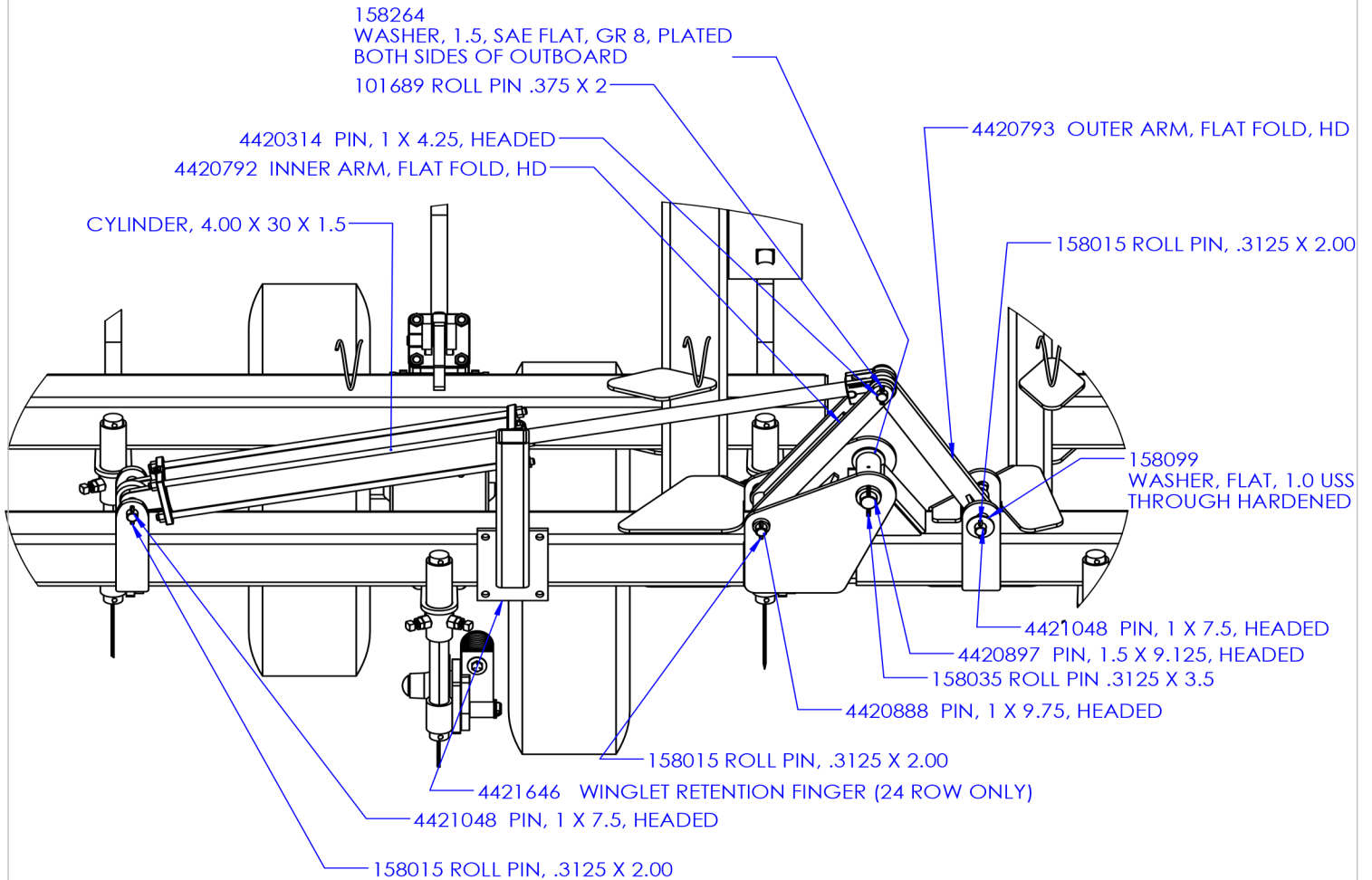

DRAWN BY	--	9/1/2020
CHECKED BY		
PRINT DATE		2/4/2025
CONFIG.	UNFOLDED	



PROPRIETARY AND CONFIDENTIAL
THE INFORMATION CONTAINED IN THIS DRAWING IS THE SOLE PROPERTY OF DALTON AG. ANY REPRODUCTION IN PART OR AS A WHOLE WITHOUT THE WRITTEN PERMISSION OF DALTON AG IS PROHIBITED.

COMMENTS:

DWG:	TR OUTBOARD FOLD	
SIZE	SHEET TITLE:	REV
A	Sheet1	A
SCALE: 1:16	SHEET 1 OF 1	

FOR PARTS, CALL 1.800.342.7498

TRIPLE RANK FRONT FOLD LINKAGE

ITEM NO.	PART NUMBER	DESCRIPTION	QTY.
1	4431257	CRANK, WINGLET FOLD	1
2	4410816	ACTUATION LINK ASSEMBLY	1
3	4431261	LINK CAP, WINGLET FOLD	1
4	152289	BOLT, .75NC X 3.00 GR8 ZINC PLATE	1
5	--	HYDRAULIC CYLINDER 3.0 X 16 X 1.5	1
6	4431297	PIN RETAINER	1
7	4431296	PIN, 1.00 DIA. GROOVED	1
8	4421669	4421669 PIN, 1 X 3.0625, HEADED	1
9	4421671	PIN, .75 X 2.5, TEARDROP HEADED	1
10	4431301	PIN, 1.312 X 11.8125, HEADLESS	1
11	4421674	PIN, 1.00 X 3.09, HEADED	1
12	101689	ROLL PIN .375X2	1
13	151829	BOLT .375 X 2.5 NC GRD 5 PLTD	1
14	150022	NUT, .375, LOCKING, PLTD	1
15	158021	NUT, CENTERLOCK, .75	1
16	4441725	ROLL PIN, 7/16" X 1.5", ZINC PLATED	1
17	158192	BOLT, 3/8-16 X 3/4 SERR FLG SC GR 5 ZINC	2

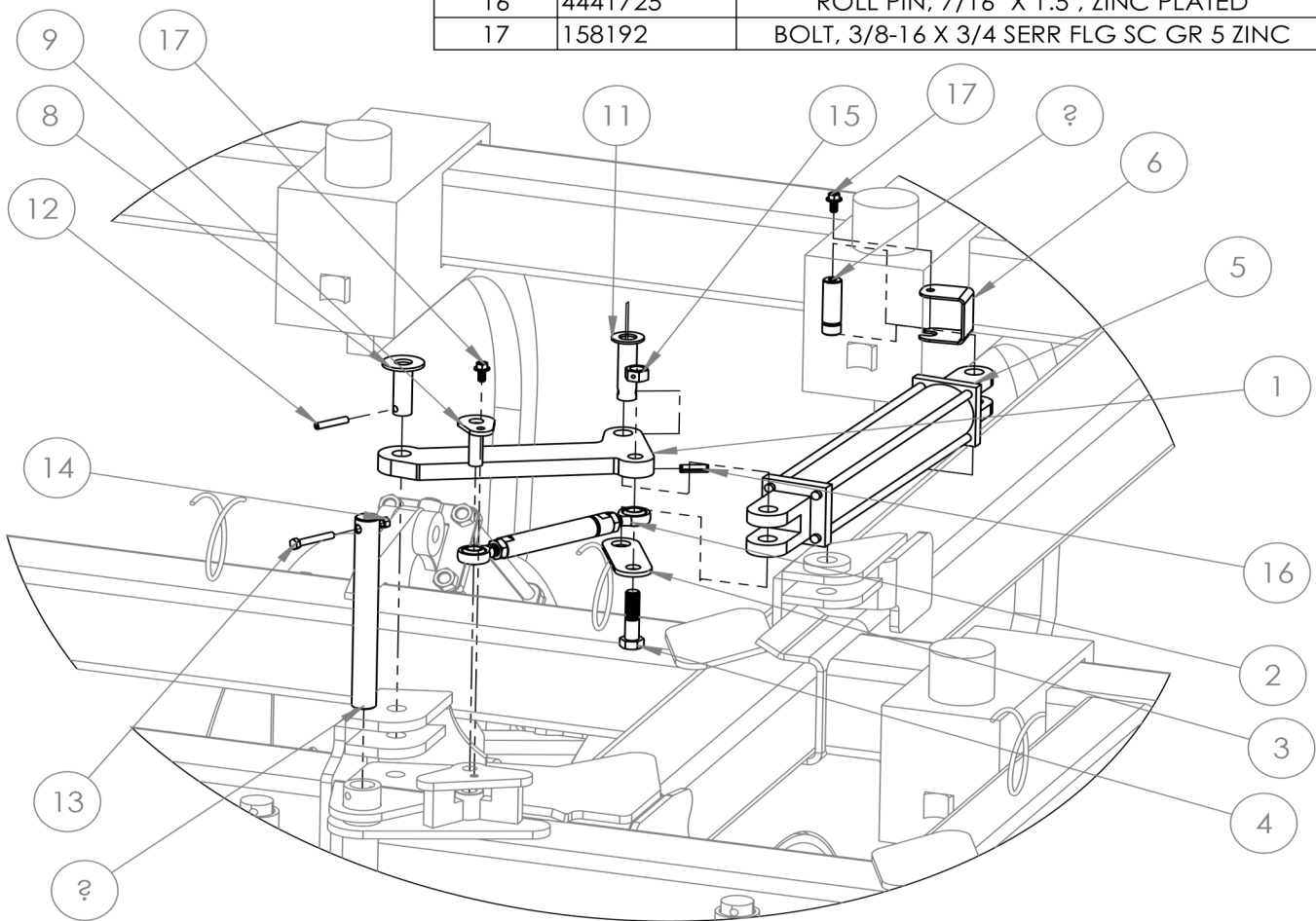

DRAWN BY	--	9/1/2020
CHECKED BY		
PRINT DATE		2/5/2025
CONFIG.	UNFOLDED	



PROPRIETARY AND CONFIDENTIAL
 THE INFORMATION CONTAINED IN THIS DRAWING IS THE SOLE PROPERTY OF DALTON AG. ANY REPRODUCTION IN PART OR AS A WHOLE WITHOUT THE WRITTEN PERMISSION OF DALTON AG IS PROHIBITED.

COMMENTS:

DWG: TR_FRONT_FOLD_LINKAGE

SIZE	SHEET TITLE:	REV
A	Sheet1	A

FOR PARTS, CALL 1.800.342.7498

SCALE: 1:10 SHEET 1 OF 1

CYLINDER LOCKS & HARDWARE

LIFT CYLINDER LOCK

SWING-AWAY CYLINDER LOCKUP, 10
4410612

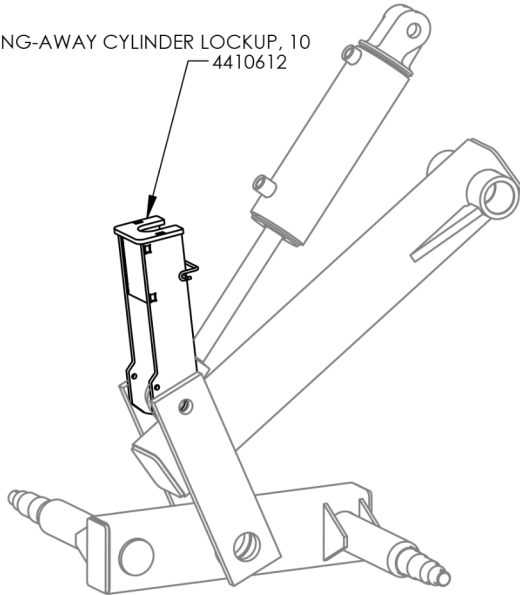

REFER TO WALKING AXLE ASSEMBLY PAGE
FOR CONNECTING HARDWARE

WING CYLINDER LOCK

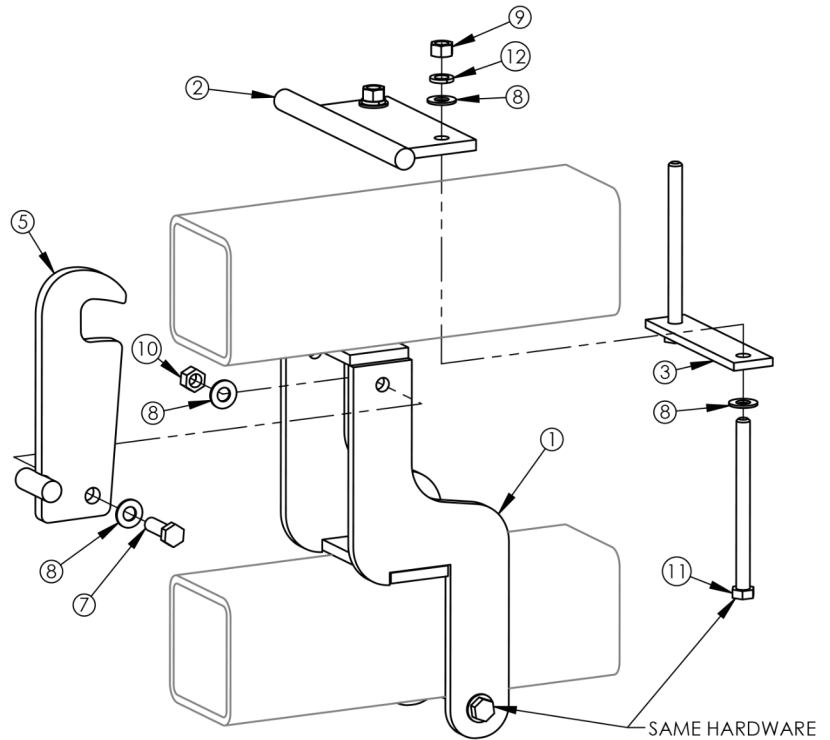
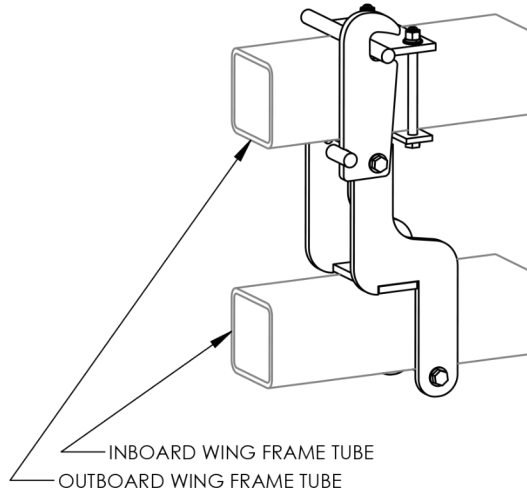

ITEM NO.	PART NUMBER	QTY
1	4420944 TB WING LOCK, 6X6, OFFSET BASE	1
2	TB 4420863 WING LOCK HOOK, 6X6	1
3	TB 4435458 BOLT PLATE, WING LOCK HOOK, 6X6	1
5	4420945 WING LATCH	1
7	152404 BOLT, .625 X 2 NC PLTD	1
8	150223 FLAT WASHER, .625 STD PLN	8
9	150010 NUT, .625 NC, PLTD	3
10	188082 NUT, .625 NC, CENTERLOCK, PLTD	1
11	152422 BOLT, .625 X 8 NC, G5	3
12	150222 LOCK WASHER, .625, PLTD	3

DRAWN BY	--	2/5/2024
CHECKED BY		
PRINT DATE		2/6/2024
CONFIG.	Default	
COMMENTS:		



PROPRIETARY AND CONFIDENTIAL
THE INFORMATION CONTAINED IN THIS
DRAWING IS THE SOLE PROPERTY OF
DALTON AG. ANY REPRODUCTION IN
PART OR AS A WHOLE WITHOUT THE
WRITTEN PERMISSION OF DALTON AG IS
PROHIBITED.

DWG: CYLINDER LOCKS AND HARDWARE

SIZE A	SHEET TITLE: Sheet1	REV A
------------------	------------------------	-----------------

FOR PARTS, CALL 1.800.342.7498

SCALE: 1:32

SHEET 1 OF 1

TOOLBAR LIGHT KIT

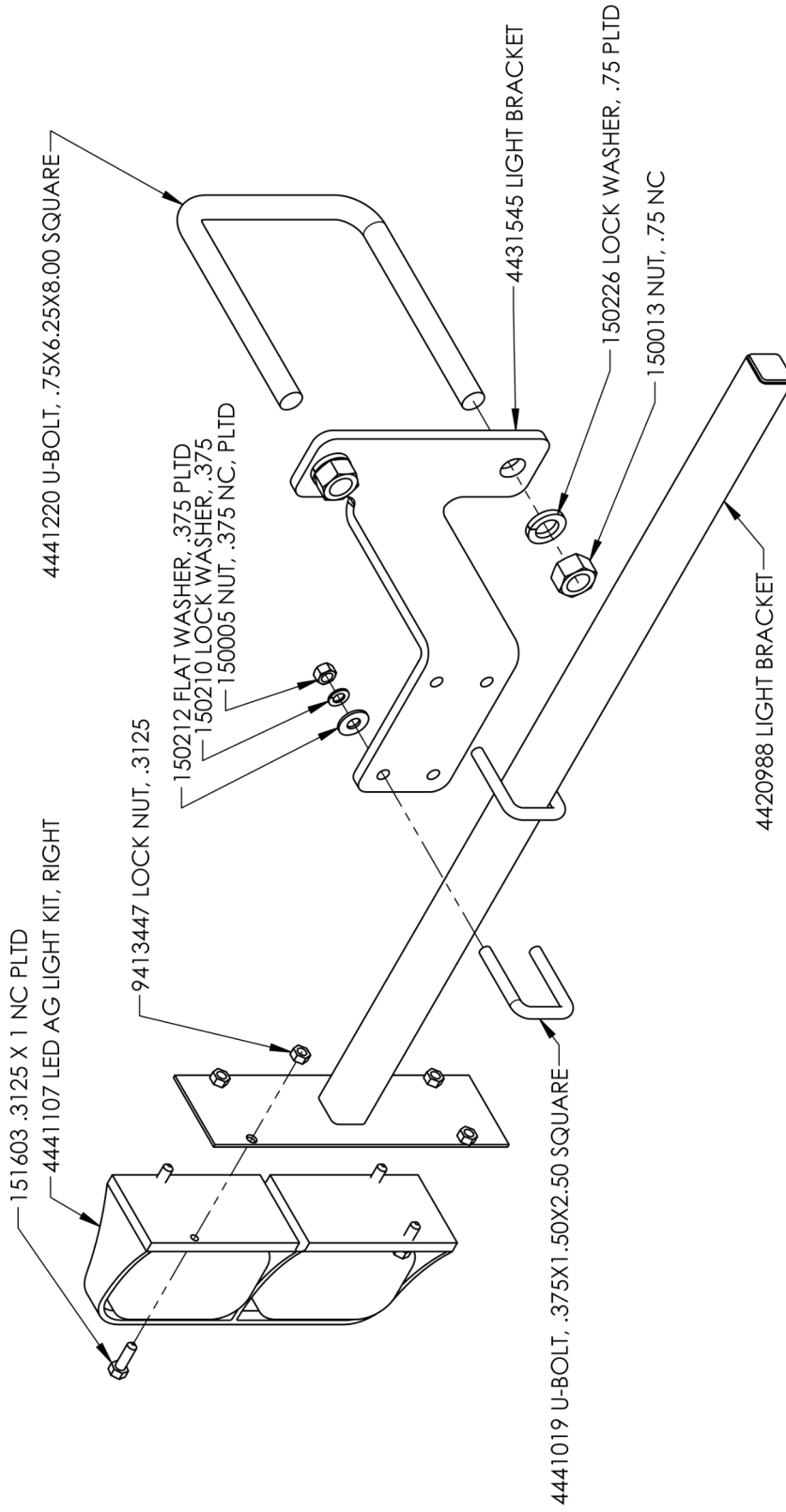

DRAWN BY	RICH SMOTHERS	2/14/2017
CHECKED BY		
PRINT DATE	2/5/2024	
CONFIG.	Default	
COMMENTS:		

NOTE:
 ASSEMBLY CONTAINS A RIGHT AND LEFT CONFIGURATION PER TOOLBAR. RIGHT CONFIGURATION SHOWN.

PROPRIETARY AND CONFIDENTIAL
 THE INFORMATION CONTAINED IN THIS DRAWING IS THE SOLE PROPERTY OF DALTON AG. ANY REPRODUCTION IN PART OR AS A WHOLE WITHOUT THE WRITTEN PERMISSION OF DALTON AG IS PROHIBITED.

DWG: TOOLBAR LIGHT KIT

SIZE	A	SHEET TITLE:	Sheet1	REV	0
SCALE:	1:12			SHEET 1 OF 1	

SLH MOUNTING HARDWARE

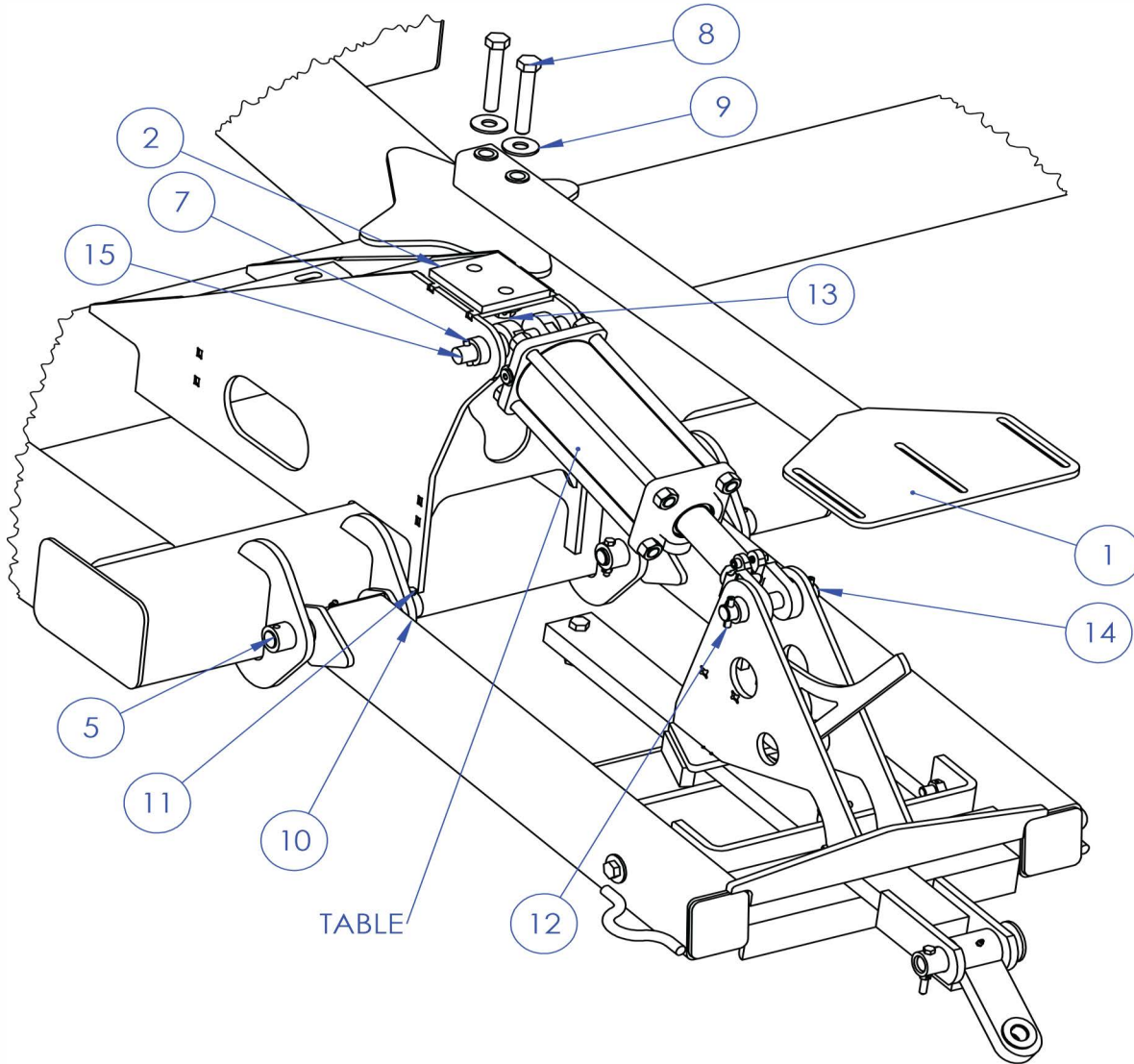

ITEM NO.	PART NUMBER	DESCRIPTION	QTY.
1	4421806	QUICK COUPLER ARM	1
2	4431393	SPACER, QUICK COUPLER MOUNT SLH	1
5	4435460	PIN, 1 X 9.75, HEADLESS	2
7	158028	ROLL PIN, .3125 X 1.5	1
8	152620	BOLT .75 X 4.5 NC GRD 5 PLTD	2
9	150227	FLAT WASHER, .75 USS PLTD	4
10	158293	5/16-18 GR8 CENTER LOCK NUT ZINC	2
11	151604	BOLT, .3125 X 2.25 NC PLTD	2
12	101689	ROLL PIN .375X2	2
13	158021	NUT, CENTERLOCK, .75	2
14	4431611	PIN, 1 X 6, HEADLESS	1
15	4420593	PIN, 1 X 7.125 HEADED	1

TOOLBAR TYPE	PART NUMBER	DESCRIPTION
DW	LION 375-10-137R WPC	CYLINDER, 3.75" X 10" X 1.37" ROD, REPHASE, 3000 PSI, WELDED,
DWHS	MID-450-10-150R	CYLINDER, 4.5 X 10.0 X 1.5 REPHASING

DRAWN BY: --
 CHECKED BY: --
 PRINT DATE: 7/11/2024
 CONFIG: Default

12/14/2020



PROPRIETARY AND CONFIDENTIAL
 THE INFORMATION CONTAINED IN THIS DRAWING IS THE SOLE PROPERTY OF DALTON AG. ANY REPRODUCTION IN PART OR AS A WHOLE WITHOUT THE WRITTEN PERMISSION OF DALTON AG IS PROHIBITED.

COMMENTS:

DWG: SLH MOUNTING HARDWARE

SIZE: **A** SHEET TITLE: Sheet1 REV: **A**

FOR PARTS, CALL 1.800.342.7498

SCALE: 1:10 SHEET 1 OF 1

REAR HITCH, SLH

ITEM NO.	PART NUMBER	DESCRIPTION	QTY.
1	4421625	REAR HITCH, SELF LEVELING	1
2	4420857	DRAW BAR, REAR HITCH, HD	1
3	4410941	FLAPPER ASSEM, FORGED SWIVEL BALL	1
4	4420858	SWING LATCH, REAR HITCH, HD	1
5	4420856	HITCH PIN, REAR HITCH, HD	1
6	4420213	PIN, 1 X 5.25, HEADED	1
7	4435468	HANDLE, REAR HITCH	1
8	4435448	LINKAGE, REAR HITCH	1
9	4440969	COMPRESSION SPRING, REAR HITCH PIN	1
10	140057	SPRING EXT. .75 X 4.5	1
11	158015	ROLL PIN, .3125 X 2.00	1
12	150005	NUT, .375 NC, PLTD	1
13	151806	BOLT, .375 X 1.5 NC, G5, PLTD	3
14	150212	FLAT WASHER USS, .375 PLTD	9
15	151808	BOLT .375 X 1.75 NC GRD 5	1
16	151816	BOLT, .375 X 3 NC, G8, PLTD	1
17	150022	NUT, .375, LOCKING, PLTD	4
18	152446	BOLT, .625 X 6 NC, G5	2
19	188082	NUT, .625 NC, CENTERLOCK, PLTD	2
20	150224	FLAT WASHER, .625 PLTD	2
21	158046	FITTING, .25", .25-28 90 GREASE FIT# 1911-B-1	2
22	4431611	PIN, 1 X 6, HEADLESS	1
23	101689	ROLL PIN .375X2	3
24	4421928	DRAWBAR STOP WELDMENT	1
25	4421669	4421669 PIN, 1 X 3.0625, HEADED	1

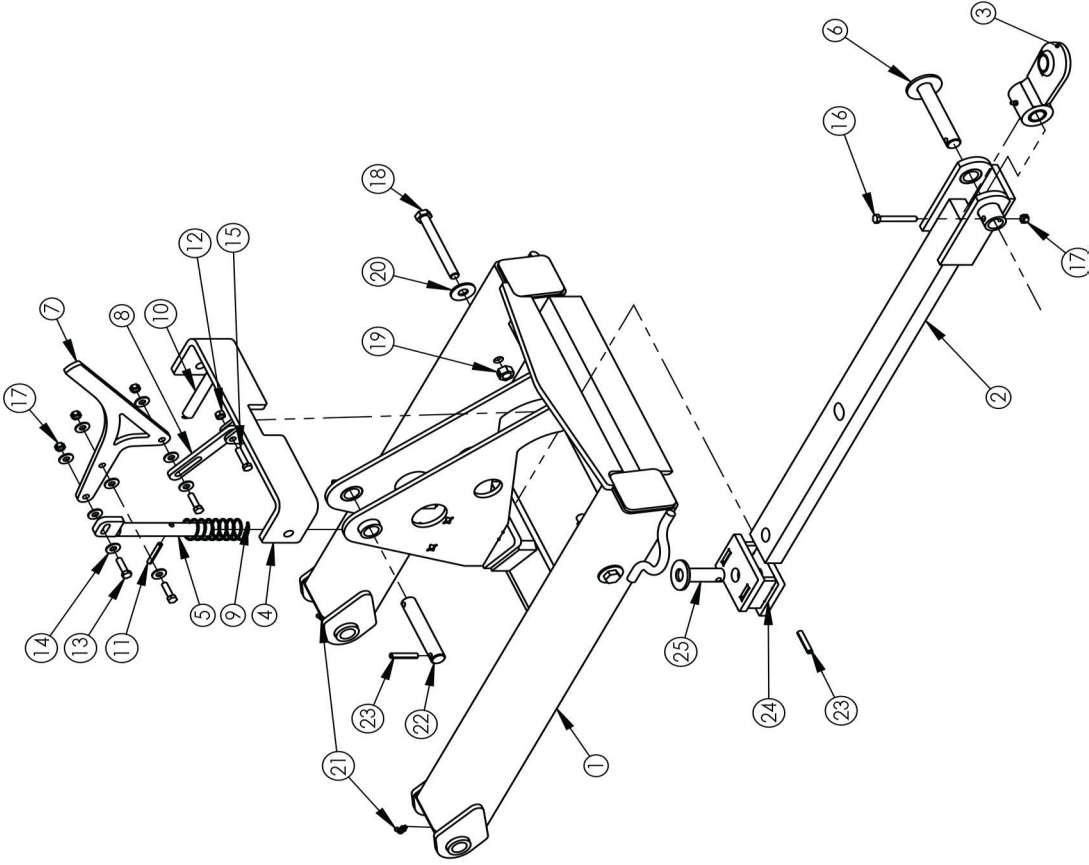

DRAWN BY Donal Sundberg 8/10/2020
 CHECKED BY
 PRINT DATE 11/7/2024
 CONFIG. Default
 COMMENTS:



DWG: 4410801 REAR SLH PARTS

PROPRIETARY AND CONFIDENTIAL
 THE INFORMATION CONTAINED IN THIS DRAWING IS THE SOLE PROPERTY OF DALTON A.G. ANY REPRODUCTION IN PART OR AS A WHOLE WITHOUT THE WRITTEN PERMISSION OF DALTON A.G. IS PROHIBITED.

SIZE SHEET TITLE: A Sheet
 REV E

SHEET 1 OF 1

FOR PARTS, CALL 1.800.342.7498

LIFT ARM WALKER

REVISIONS

REV.	DESCRIPTION	DATE	APPD
A	RELEASED	8/7/2024	DES

ITEM NO.	PART NUMBER	DESCRIPTION	QTY.
1	4421917	LIFT WHEEL WALKER ARM MEGA, UNIT BRG, WITH DEPTH STOP	1
2	4410937	WALKER W HUBS, 758 8 BOLT TR, UNIT BEARING	1
3	4410813	WHEEL AND TIRE ASSEM VF295/75R22.5	2
4	4421048	PIN, 1 X 7.5, HEADED	1
5	158015	ROLL PIN, .3125 X 2.00	1
6	4440887	COMPOSITE BUSHING	2
7	158339	BOLT, 1"-14 X 9, GR 8, PLATED YELLOW	1
8	158099	WASHER, FLAT, 1.0 USS THROUGH HARDENED	2
9	158327	NUT, TOP LOCK, 1-14, GRADE C, ZINC PLATED	1
10	4421867	WELDMENT, LINK, BOLTED, LIFT ARM DEPTH CONTROL BRACKET	1
11	151805	BOLT, .375 X 1.25 NC, PLTD	1
12	150005	NUT, .375 NC, PLTD	1
13	150200	LOCK WASHER, .375 MED SPRING PLATED	1
14	151414	BOLT, .25 X 1 NC PLTD	1
15	150202	LOCK WASHER, .25 PLTD	1
16	150024	NUT, .25 NC, PLTD	1

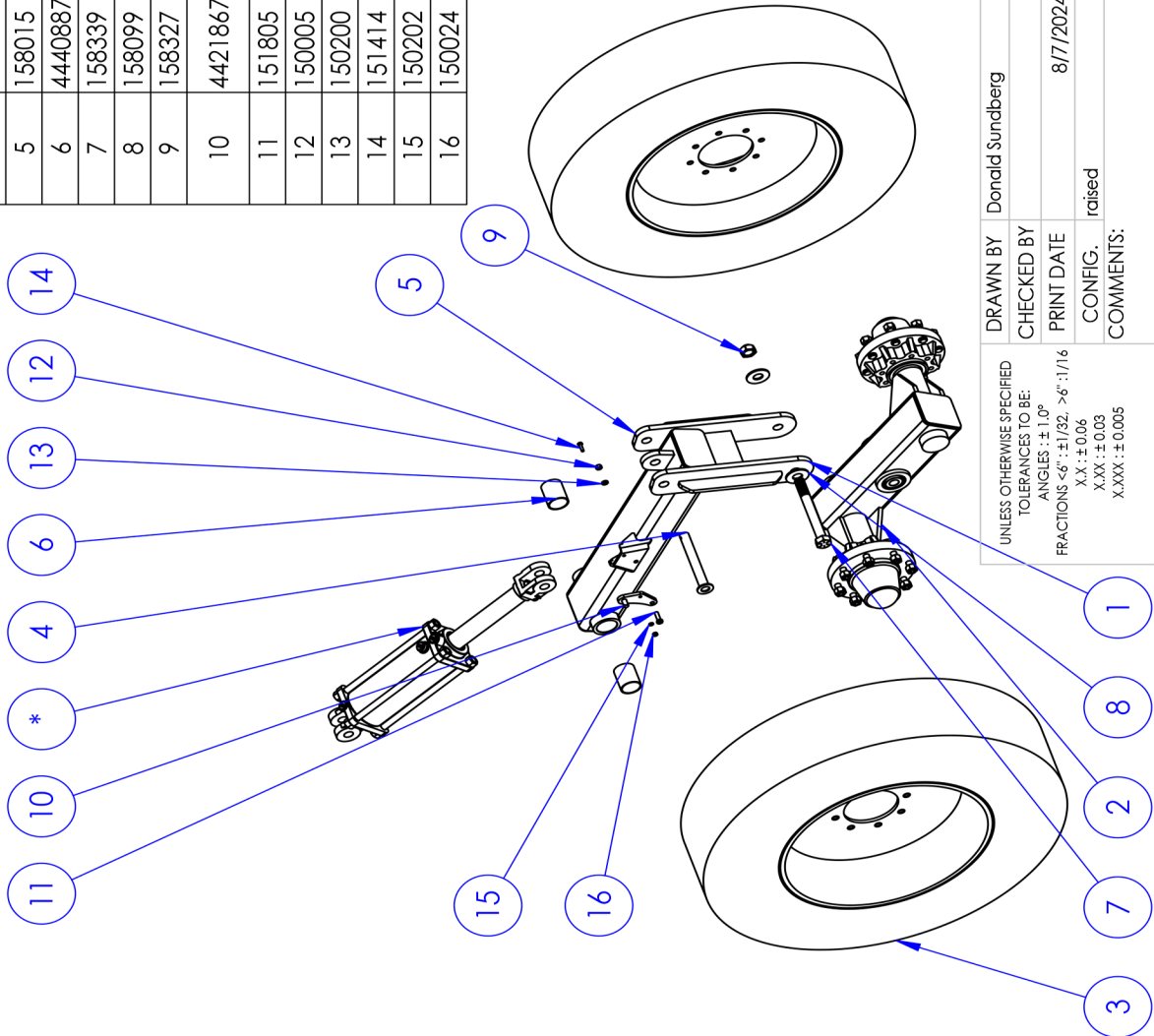

8/7/2024

Donald Sundberg

UNLESS OTHERWISE SPECIFIED
TOLERANCES TO BE:
ANGLES: ± 1.0°
FRACTIONS <6": ±1/32, >6": 1/16
X.X: ± 0.06
X.XX: ± 0.03
X.XXX: ± 0.005

DWG: 4410939
LIFT ARM W WALKERS, TR, UNIT BRG, DEPTH
SIZE SHEET TITLE: CONTROL Sheet
REV A

SCALE: 1:20 SHEET 1 OF 1

PROPRIETARY AND CONFIDENTIAL
THE INFORMATION CONTAINED IN THIS DRAWING IS THE SOLE PROPERTY OF DALTON AG. ANY REPRODUCTION IN PART OR AS A WHOLE WITHOUT THE WRITTEN PERMISSION OF DALTON AG IS PROHIBITED.

WALKER UNIT BEARING

ITEM NO.	PART NUMBER	DESCRIPTION	QTY.
1	4421915	WALKER AXLE, TR BAR, UNIT BEARING	1
2	2001113	HUB, COMPLETE, 8 BOLT, 758	2
3	2001116	RACE, 3.8125 OD X .625	2
4	1002404	BEARING CUP, 2.891 OD X .580 W	2
5	2001115	BEARING CONE, 2.25 ID X .8640	2
6	1002407	BEARING CONE, 1.625 ID X .780	2
7	2001122	DUST CAP, 8B H 758	2
8	2001114	SEAL, 758 (8B H), 3" X 4" X .25" GREASE SEAL	2
9	2001119	WASHER, SAE FLAT, 1.25 PLATED	2
10	2000141	NUT, 1-1/4 - 12 SLOTTED HEX SAE	2
11	2001121	COTTER PIN, 3/16" X 2-1/2"	2
12	2001118	NUT, 5/8" FLANGE, 8B H	16
13	4431721	SPACER, INNER, UNIT BEARING WALKER, TR	1
14	4441771	DOUBLE ROW TAPERED ROLLER BEARING	2
15	4431579	ARBOR, UNIT BEARING WALKER ASSEM	2
16	158316	65MM INTERNAL RETAINING RING	2

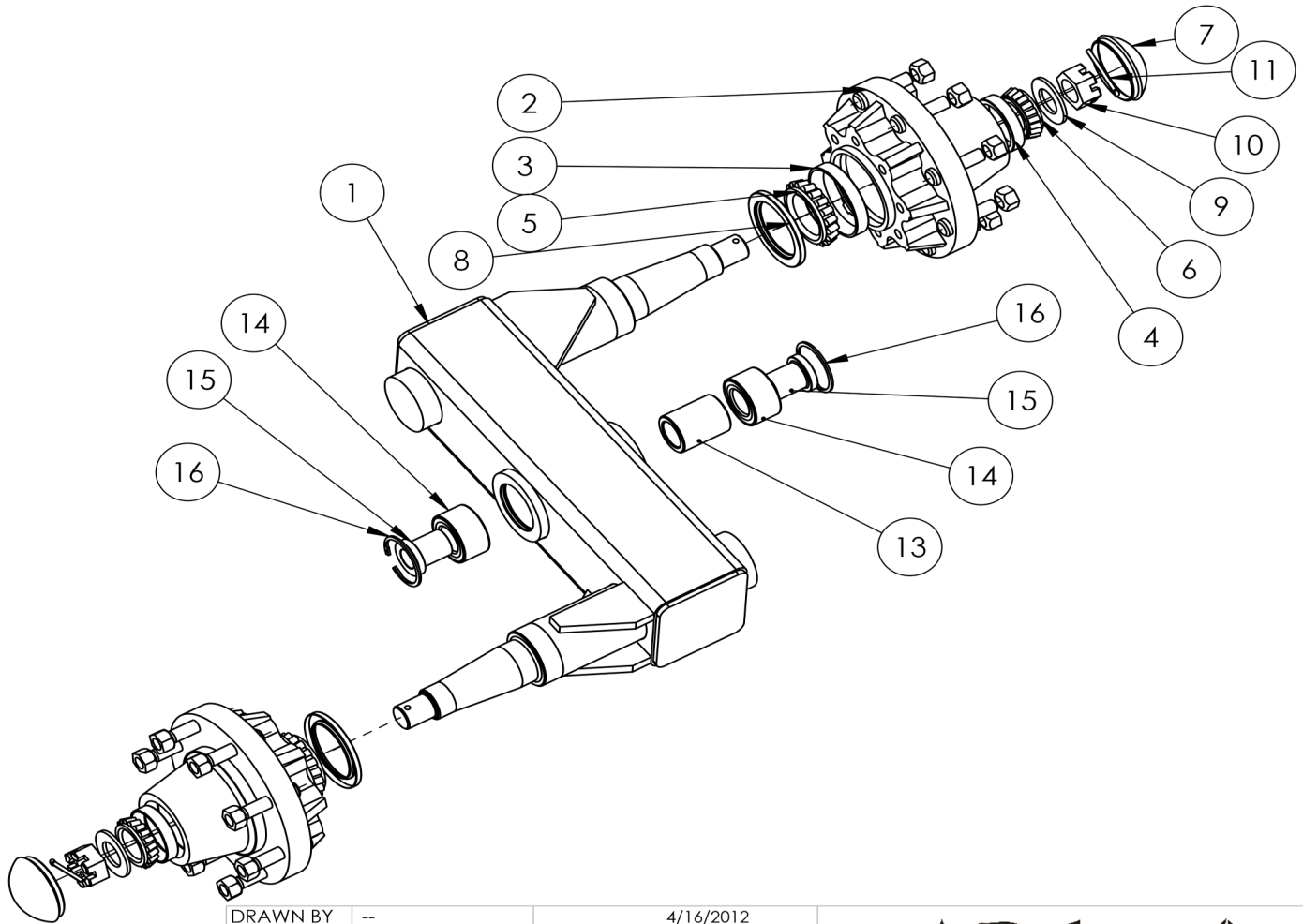

DRAWN BY	--	4/16/2012
CHECKED BY		
PRINT DATE		1/28/2025
CONFIG.	Default	



PROPRIETARY AND CONFIDENTIAL
 THE INFORMATION CONTAINED IN THIS DRAWING IS THE SOLE PROPERTY OF DALTON AG. ANY REPRODUCTION IN PART OR AS A WHOLE WITHOUT THE WRITTEN PERMISSION OF DALTON AG IS PROHIBITED.

COMMENTS:

DWG: WALKER, TRIPPLE RANK, UNIT BEARING

SIZE	SHEET TITLE:	4410937	REV
A			A

FOR PARTS, CALL 1.800.342.7498

SCALE: 1:8 SHEET 1 OF 1

8-BOLT HUB ASSEMBLY

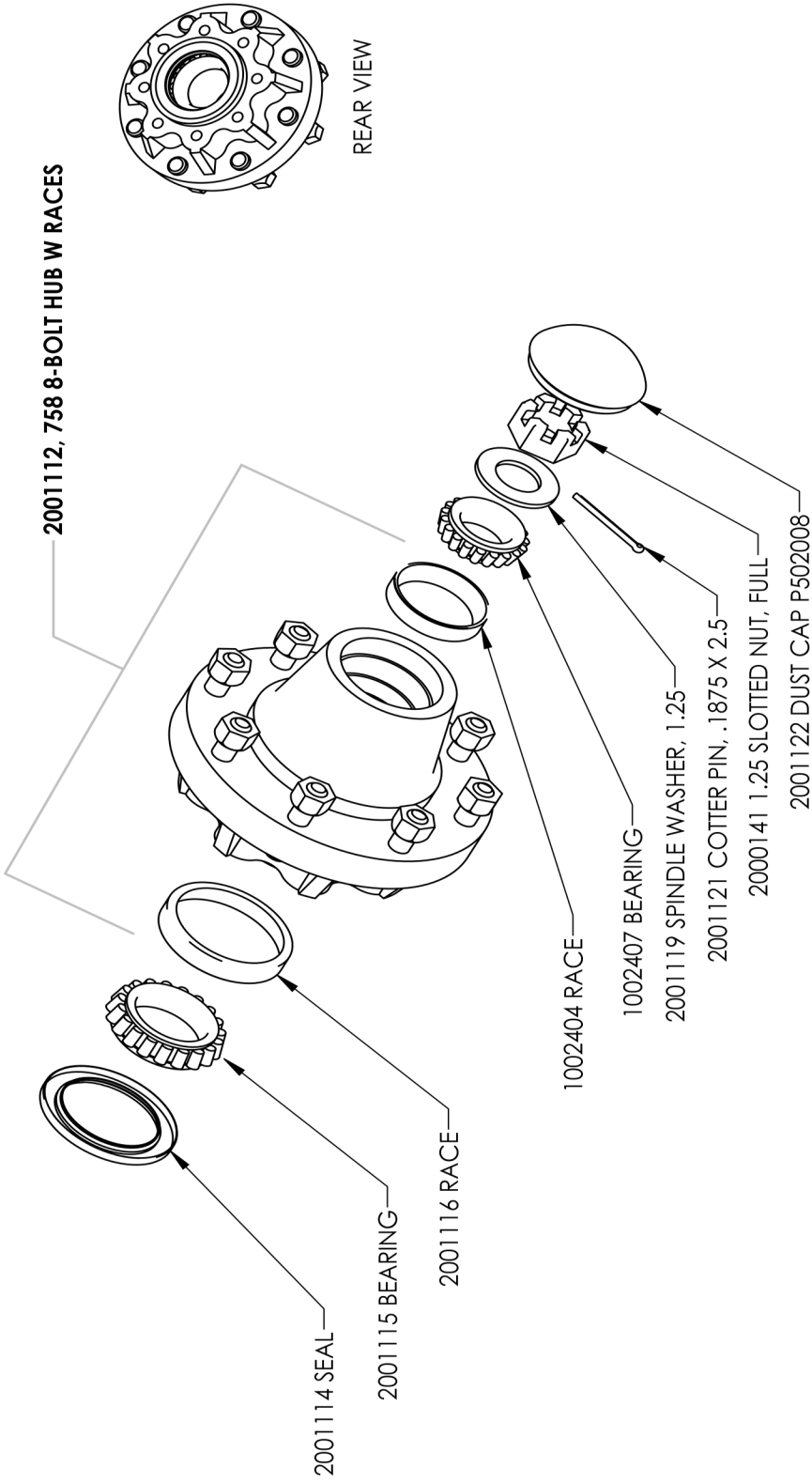

2001118 LUG NUT, .625 NC - Quantity - 8
 2001117 LUG BOLT, .625 NC - Quantity - 8

2001113, 758 8-BOLT HUB ASSEMBLY

DRAWN BY	RICH SMOTHERS	3/2/2012
CHECKED BY		
PRINT DATE	2/10/2023	
CONFIG.	Default	
COMMENTS:		



DWG: 2001113, 758 8-BOLT HUB ASSEMBLY

SIZE	A	SHEET TITLE:	Sheet1	REV	A
SCALE:	1:5			SHEET 1 OF 1	

PROPRIETARY AND CONFIDENTIAL
 THE INFORMATION CONTAINED IN THIS DRAWING IS THE SOLE PROPERTY OF DALTON AG. ANY REPRODUCTION IN PART OR AS A WHOLE WITHOUT THE WRITTEN PERMISSION OF DALTON AG IS PROHIBITED.

DEPTH CONTROL ASSEMBLY

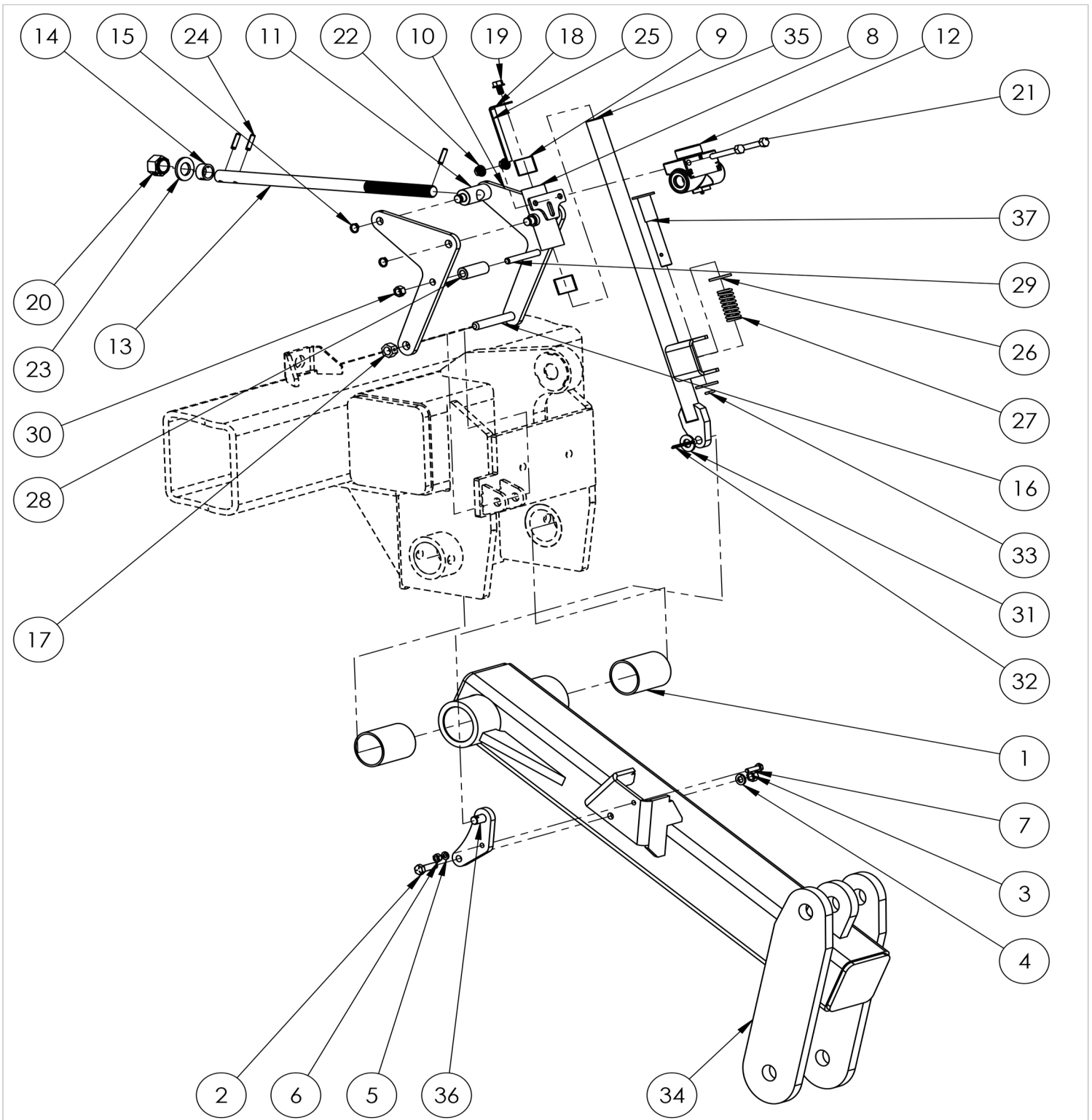

DRAWN BY	--	8/12/2024
CHECKED BY		
PRINT DATE		8/12/2024
CONFIG.	EXPLODED	



PROPRIETARY AND CONFIDENTIAL
 THE INFORMATION CONTAINED IN THIS DRAWING IS THE SOLE PROPERTY OF DALTON AG. ANY REPRODUCTION IN PART OR AS A WHOLE WITHOUT THE WRITTEN PERMISSION OF DALTON AG IS PROHIBITED.

COMMENTS:

DWG: DEPTH CONTROL ASSY

SIZE	SHEET TITLE:	REV
A	Sheet1	A

FOR PARTS, CALL 1.800.342.7498

SCALE: 1:8 SHEET 1 OF 2

DEPTH CONTROL ASSEMBLY

ITEM NO.	PART NUMBER	DESCRIPTION	QTY.
1	4440887	COMPOSITE BUSHING	2
2	151805	BOLT, .375 X 1.25 NC, PLTD	1
3	150005	NUT, .375 NC, PLTD	1
4	150200	LOCK WASHER, .375 MED SPRING PLATED	1
5	150202	LOCK WASHER, .25 PLTD	1
6	150024	NUT, .25 NC, PLTD	1
7	151414	BOLT, .25 X 1 NC PLTD	1
8	4421630	SLEEVE / BRACKET WELDMENT DEPTH STOP	1
9	4441764	BEARING 1.00 X 1.125 X 1.00	2
10	4431193	LINKAGE BAR, DEPTH STOP	2
11	4431192	ROUND DEPTHSTOP ADJUSTMENT NUT	1
12	4441603	STROKE CONTROL VALVE, PRINCE PM-SC10	1
13	4431724	ROD ADJUSTMENT, THREADED	1
14	4431190	COLLAR, ADJUSTMENT ROD	1
15	158282	RETAINING RING .500 DIA. HD	4
16	152236	BOLT .5 X 3.5 NC, G5	1
17	158178	NUT, .5 NC, CENTERLOCK, PLTD	1
18	4431191	GAGE INDICATOR DEPTH STOP	1
19	158283	5/16" X .50" NC PLATED G5 FLANGE SERRATED	1
20	4431188	HEX HEAD, PINNED	1
21	151604	BOLT, .3125 X 2.25 NC PLTD	2
22	158285	5/16 NC SERR FLANGE NUT, GR 5, ZINC	2
23	158284	WASHER, FLAT .750 SAE PLATED	1
24	158281	1/4 X 1 SLOTTED SPRING PIN PLATED	3
25	4441601	DECAL, DEPTH CONTROL	1
26	158288	.625 SAE FLAT WASHER ZINC PLATED	2
27	4441735	COMPRESSION SPRING, 2" LONG, 0.875" OD, 0.635" ID	1
28	4431450	SPACER, DEPTH CONTROL LINKAGE	1
29	158144	BOLT .375 X 3 NC SS	1
30	150022	NUT, .375, LOCKING, PLTD	1
31	150219	FLAT WASHER, .5 SAE	1
32	158113	COTTER PIN, .156 X 1.50	1
33	158320	COTTER PIN, .125 X 1.00 LONG, PLATED	1
34	4421917	LIFT WHEEL WALKER ARM- DEPTH CONTROL 1" AXLE	1
35	4421640	WELDMENT, DEPTH CONTROL ROD V2	1
36	4421867	WELDMENT, LINK, BOLTED, LIFT ARM DEPTH CONTROL BRACKET	1
37	4421862	PLUNGER WELDMENT, DEPTH CONTROL	1

DRAWN BY	--	8/12/2024
CHECKED BY		
PRINT DATE		8/12/2024
CONFIG.	EXPLODED	



PROPRIETARY AND CONFIDENTIAL
 THE INFORMATION CONTAINED IN THIS DRAWING IS THE SOLE PROPERTY OF DALTON AG. ANY REPRODUCTION IN PART OR AS A WHOLE WITHOUT THE WRITTEN PERMISSION OF DALTON AG IS PROHIBITED.

COMMENTS:

DWG:	DEPTH CONTROL ASSY	
SIZE	SHEET TITLE:	REV
A	Sheet2	A

FOR PARTS, CALL 1.800.342.7498

SCALE: 1:8 SHEET 2 OF 2

DEPTH CONTROL VALVE PLUMBING

ITEM NO.	PART NUMBER	DESCRIPTION	QTY.
1	4441603	STROKE CONTROL VALVE	1
2	4441593	.5M ORFSM X .5M SAEORB 90° ELBOW	1
3	4441592	.50" SAE ORB TO .50" ORFS STR. ADAPTER	1
4	4441645	PLUG, HOLLOW HEX, -8 SAE ORB	1

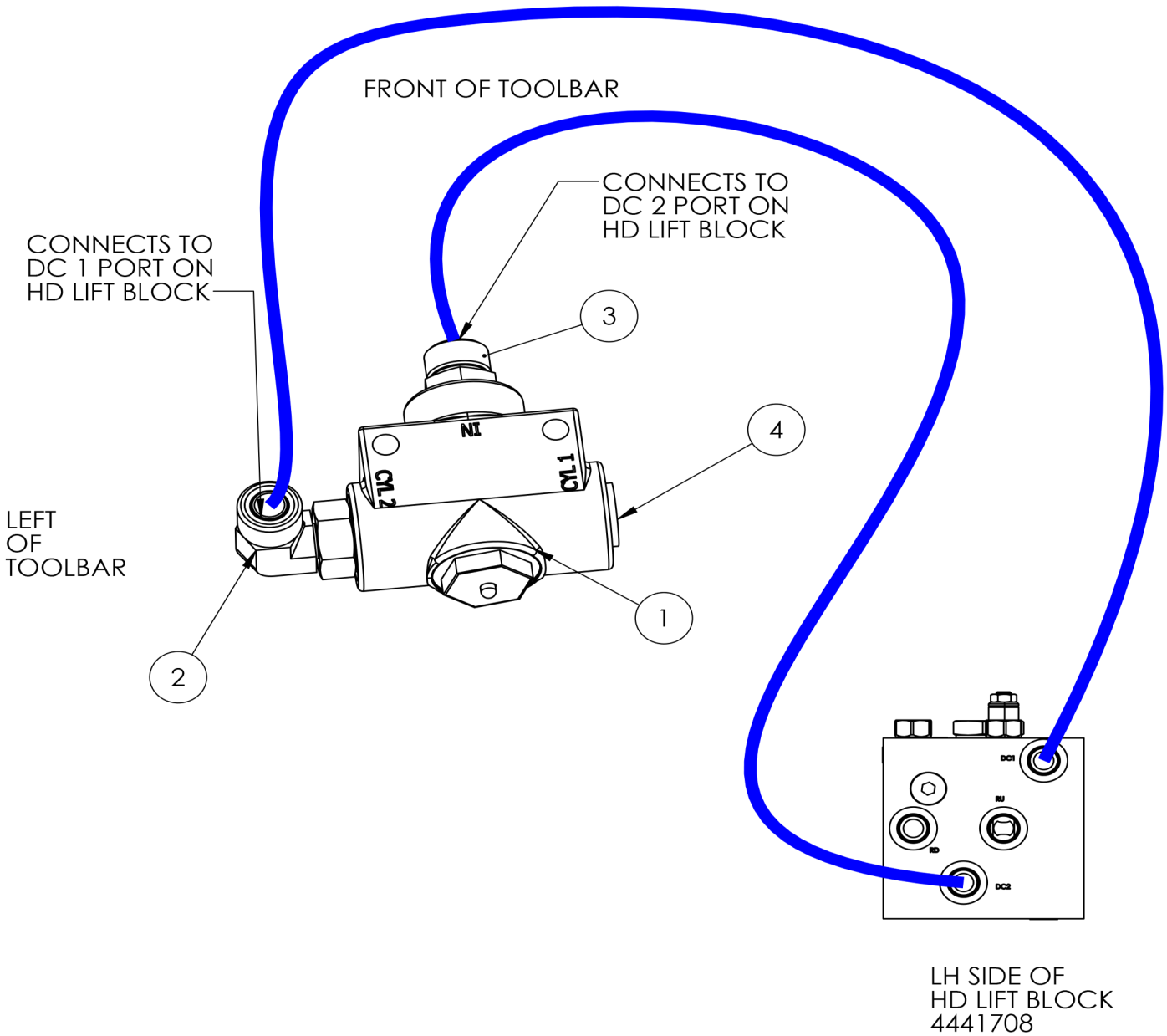

DRAWN BY	--	8/12/2024
CHECKED BY		
PRINT DATE		8/12/2024
CONFIG.	Default	



PROPRIETARY AND CONFIDENTIAL
 THE INFORMATION CONTAINED IN THIS DRAWING IS THE SOLE PROPERTY OF DALTON AG. ANY REPRODUCTION IN PART OR AS A WHOLE WITHOUT THE WRITTEN PERMISSION OF DALTON AG IS PROHIBITED.

COMMENTS:

DWG: DEPTH CONTROL VALVE PLUMBING

SIZE A	SHEET TITLE: Sheet1	REV A
------------------	------------------------	-----------------

FOR PARTS, CALL 1.800.342.7498

SCALE: 1:2 SHEET 1 OF 1

4410912 EDGE HD DISC SEALER

ITEM NO.	PART NUMBER	DESCRIPTION	QTY.
1	4421430-BK	EDGE HD UPPER MOUNT MACHINED	1
2	4420303	PIVOT ARM, HD	2
3	4440815	SEAL, HD DISC SEALER, 1.372 X 1.979 X .432	2
4	4440816	BEARING CONE, HD DISC SEALER	4
5	4440817	BEARING CUP, HD DISC SEALER	4
6	158003	NUT, SLOTTED, 3/4-16, 3/4-16 SLT HEX NUT	2
7	158012	WASHER, 3/4", 3/4 SAE FLAT WASHER	2
8	158113	COTTER PIN, .156 X 1.50	2
9	4440814	DUST CAP, 2", HD DISC SEALER	2
10	151222	GREASE FITTING	2
11	4435859	HD CAP RETAINER	2
12	158006	FLANGE BOLT, .5 X 1.75 NC, G5	4
13	158007	FLANGE NUT, .5 NC	4
14	151805	BOLT, .375 X 1.25 NC, PLTD	2
15	150248	LOCK WASHER, .375, SS	2
16	150005	NUT, .375 NC, PLTD	2
17	4421749	HUB BRACKET, WELDMENT, HD, UNIT HUB	2
18	158334	NUT, M22-1.5 GR 8.8, ZINC	2
19	4441760	HUB, UNIT BEARING, DISC SEALER	2
20	158335	WASHER, LOCKING FLAT, ZINC PLATED	2
21	4431390	D-SPACER UNIT TYPE HUB	2
22	158312	FLANGE BOLT, M12-1.25 X 20, GR 10.9, ZINC	8
23	4431391	HUB CAP	2
24	4440785	BLADE, 18 INCH NOTCHED	2
25	158277	BOLT, .5625 X 3 NC GR 8	2
26	158073	NUT, .5625 NC, CENTERLOCK, PLTD	2

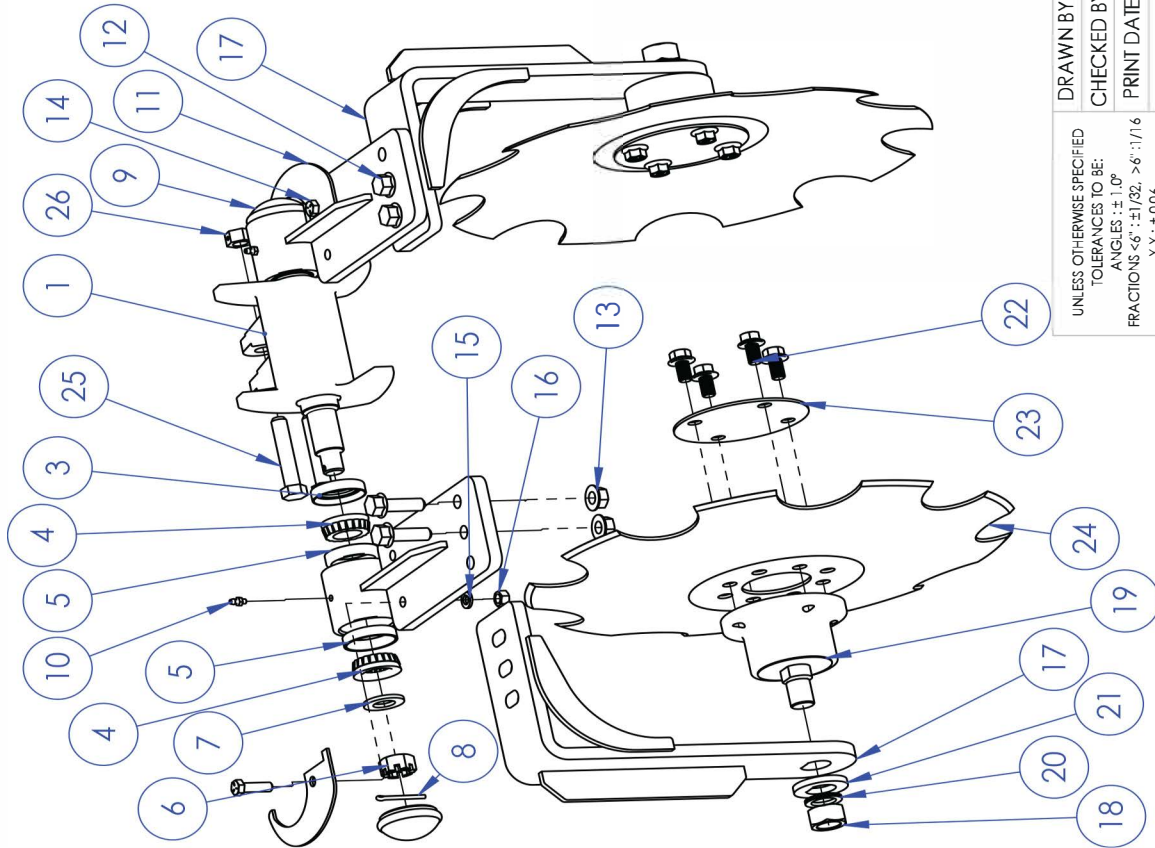

UNLESS OTHERWISE SPECIFIED
TOLERANCES TO BE:
ANGLES: ± 1.0°
FRACTIONS <6": ±1/32; >6": 1/16
X.X: ± 0.006
X.XX: ± 0.003
X.XXX: ± 0.005

DRAWN BY Tyler Jackson
CHECKED BY
PRINT DATE 12/2/2024
CONFIG. BUILT
COMMENTS:

7/12/2024

Dalton
USA
A G P R O D U C T S
602 E. VAN BUREN ST., LENOX, IA 50851

DWG: 4410912

EDGE HD DISC SEALER

PROPRIETARY AND CONFIDENTIAL
THE INFORMATION CONTAINED IN THIS DRAWING IS THE SOLE PROPERTY OF DALTON AG. ANY REPRODUCTION IN PART OR AS A WHOLE WITHOUT THE WRITTEN PERMISSION OF DALTON AG IS PROHIBITED.

SIZE SHEET TITLE: **A** Sheet1
SCALE: 1:16
REV **0**

4410912-OS EDGE HD OFF SET DISC SEALER

#	PART NUMBER	DESCRIPTION	QTY.
1	4421430-BK	EDGE HD UPPER MOUNT MACHINED	1
2	4420581	PIVOT ARM, HD, LONG	1
3	4420303	PIVOT ARM, HD	1
4	4440815	SEAL, HD DISC SEALER, 1.372 X 1.979 X .432	2
5	4440816	BEARING CONE, HD DISC SEALER	4
6	4440817	BEARING CUP, HD DISC SEALER	4
7	158003	NUT, SLOTTED, 3/4-16, 3/4-16 SLT HEX NUT	2
8	158012	WASHER, 3/4", 3/4 SAE FLAT WASHER	2
9	158113	COTTER PIN, .156 X 1.50	2
10	4440814	DUST CAP, 2", HD DISC SEALER	2
11	151222	GREASE FITTING	2
12	4435859	HD CAP RETAINER	2
13	151802	BOLT, .375 X 1 NC, PLTD	2
14	150210	LOCK WASHER, .375	2
15	150005	NUT, .375 NC, PLTD	2
16	158006	FLANGE BOLT, .5 X 1.75 NC, G5	4
17	158007	FLANGE NUT, .5 NC	4
18	4421749	HUB BRACKET, WELDMENT, HD, UNIT HUB	2
19	158334	NUT, M22-1.5 GR 8.8, ZINC	2
20	4441760	HUB, UNIT BEARING, DISC SEALER	2
21	158335	WASHER, LOCKING FLAT, ZINC PLATED	2
22	4431390	D-SPACER UNIT TYPE HUB	2
23	158312	FLANGE BOLT, M12-1.25 X 20, GR 10.9, ZINC	8
24	4431391	HUB CAP	2
25	4440785	BLADE, 18 INCH NOTCHED	2
26	158277	BOLT, .5625 X 3 NC GR 8	2
27	158073	NUT, .5625 NC, CENTERLOCK, PLTD	2

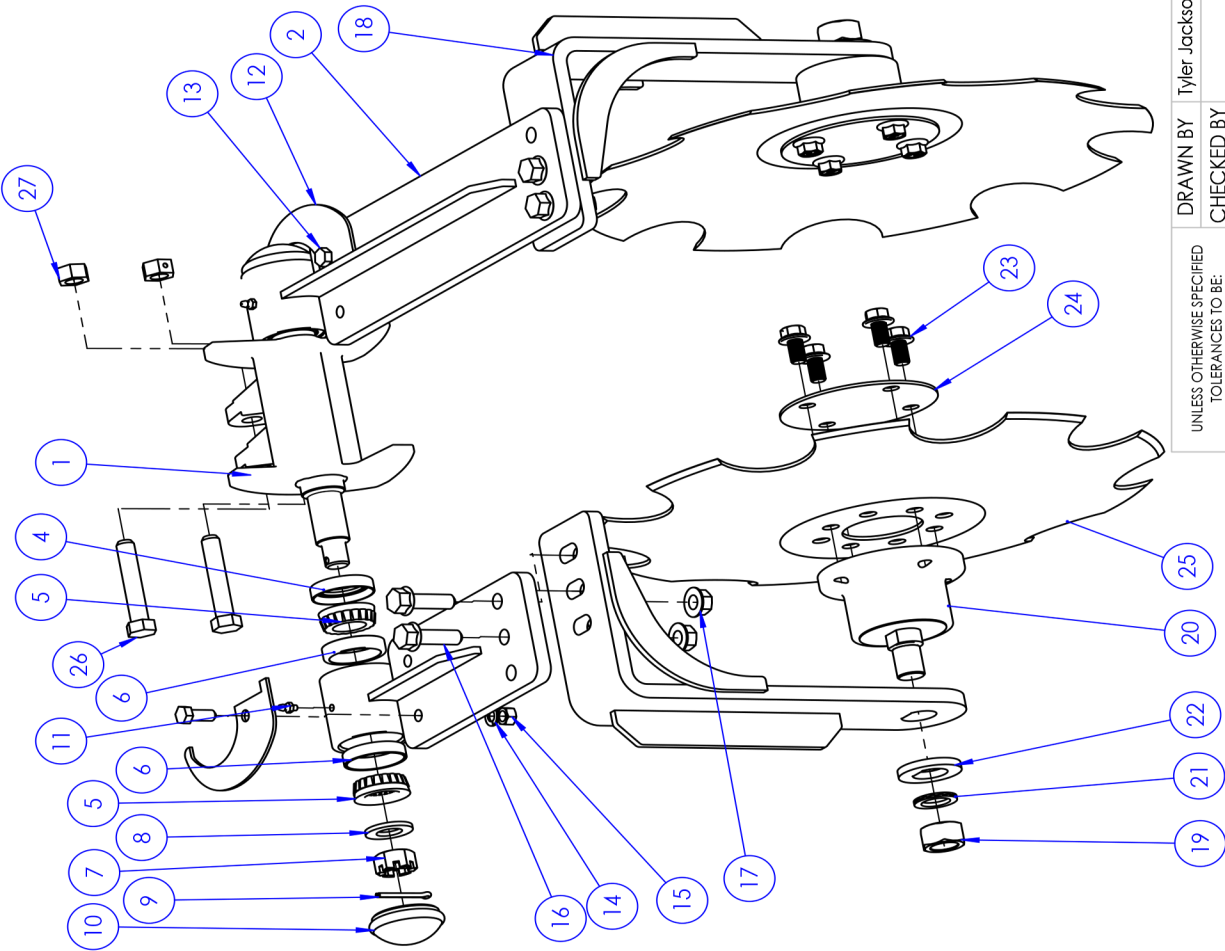

DWG: 4410912-OS-MAN

EDGE HD DISC SEALER UNIT BEARING HUBS WITH
 SIZE SHEET TITLE: OFFSET ARMS
 Sheet 1
 REV 0

SCALE: 1:16 SHEET 1 OF 1

DRAWN BY Tyler Jackson 7/23/2024
 CHECKED BY
 PRINT DATE 12/2/2024
 CONFIG. BUILT
 COMMENTS:

UNLESS OTHERWISE SPECIFIED
 TOLERANCES TO BE:
 ANGLES: ± 1.0°
 FRACTIONS <6": ±1/32, >6": 1/16
 X.X: ± 0.06
 X.XX: ± 0.03
 X.XXX: ± 0.005

PROPRIETARY AND CONFIDENTIAL
 THE INFORMATION CONTAINED IN THIS DRAWING IS THE SOLE PROPERTY OF DALTON AG. ANY REPRODUCTION IN PART OR AS A WHOLE WITHOUT THE WRITTEN PERMISSION OF DALTON AG IS PROHIBITED.

C:_EPDM_Yqualif\ROW UNITS\DISC SEALER\DS ASSEMBLY

5 4 3 2 1

4410925 EDGE SPRING LOADED DISC SEALER

4410925 EDGE SPRING LOADED DISC SEALER

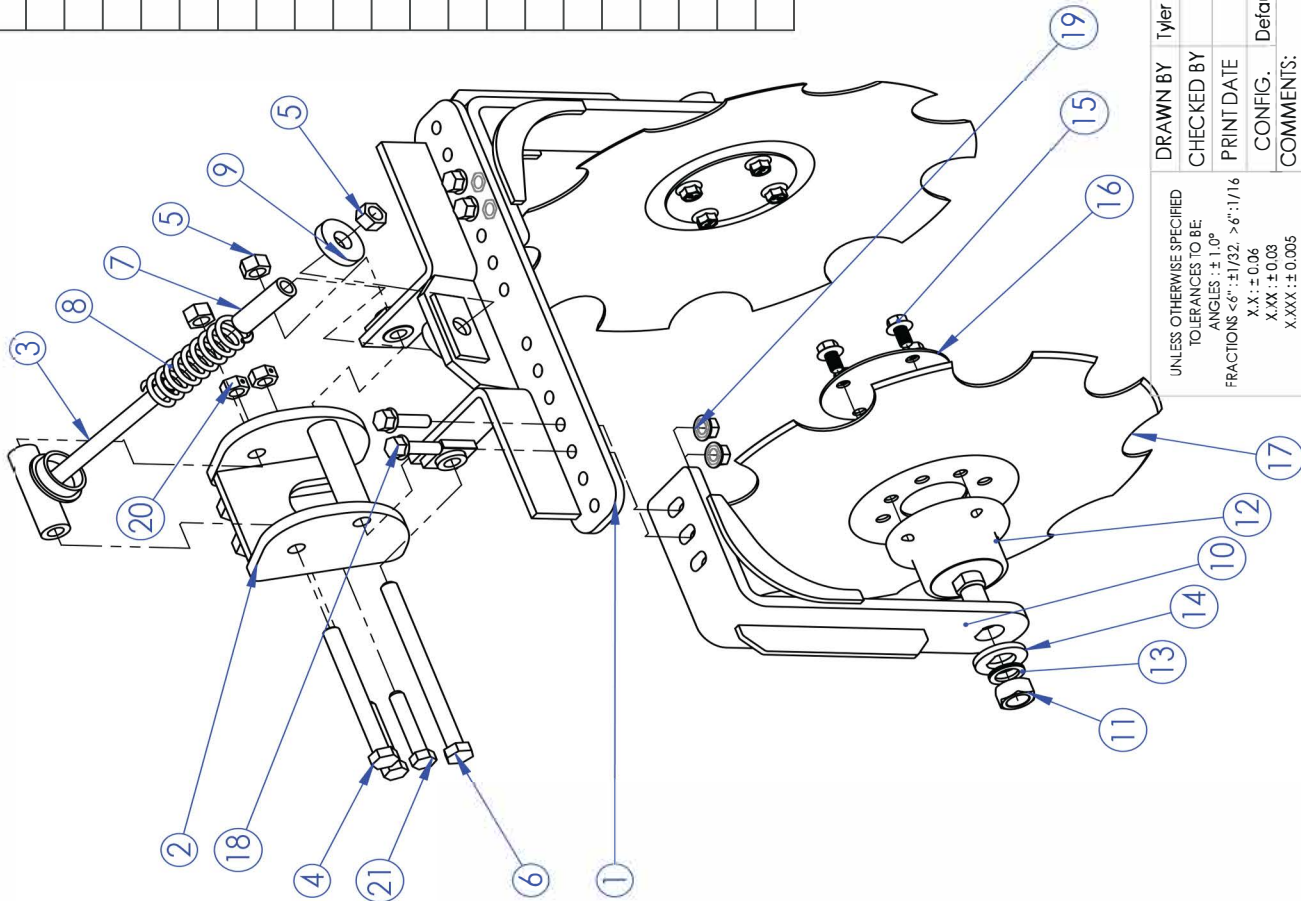

ITEM NO.	PART NUMBER	DESCRIPTION	QTY.
1	4421212	ARM BRACKET	1
2	4421408	EDGE SPRING LOADED SHANK MOUNT	1
3	4421214	SPRING BOLT	1
4	152446	BOLT, .625 X 6 NC, G5	1
5	150011	NUT, .625 NC, LOCKING, PLTD	3
6	152422	BOLT, .625 X 8, G5	1
7	951002-2.75	DOM, .875 X 12 GA	1
8	4441147	DISC SEALER SPRING	1
9	4435864	BOLT WASHER, .375	1
10	4421749	HUB BRACKET, WELDMENT, HD, UNIT HUB	2
11	158334	NUT, M22-1.5 GR 8.8, ZINC	2
12	4441760	HUB, UNIT BEARING, DISC SEALER	2
13	158335	WASHER, LOCKING FLAT, ZINC PLATED	2
14	4431390	D-SPACER UNIT TYPE HUB	2
15	158312	FLANGE BOLT, M12-1.25 X 20, GR 10.9, ZINC	8
16	4431391	HUB CAP	2
17	4440785	BLADE, 18 INCH NOTCHED	2
18	158006	FLANGE BOLT, .5 X 1.75 NC, G5	4
19	158007	FLANGE NUT, .5 NC	4
20	158073	NUT, .5625 NC, CENTERLOCK, PLTD	2
21	158277	BOLT, .5625 X 3 NC GR 8	2



DRAWN BY: Tyler Jackson
 CHECKED BY:
 PRINT DATE: 8/13/2024
 CONFIG: Default
 COMMENTS:

UNLESS OTHERWISE SPECIFIED
 TOLERANCES TO BE:
 ANGLES: ± 1.0°
 FRACTIONS <6": ±1/32, >6": 1/16
 X.X: ± 0.06
 X.XX: ± 0.03
 X.XXX: ± 0.005

DWG: 4410925
 EDGE SPRING LOADED DISC SEALER
 SHEET TITLE: Sheet1
 SIZE: A
 SCALE: 1:12
 SHEET 1 OF 1

PROPRIETARY AND CONFIDENTIAL
 THE INFORMATION CONTAINED IN THIS DRAWING IS THE SOLE PROPERTY OF DALTON AG. ANY REPRODUCTION IN PART OR AS A WHOLE WITHOUT THE WRITTEN PERMISSION OF DALTON AG IS PROHIBITED.

4410926, HD SIDE DRESS DISC SEALER 14.5 INCH ARMS

ASSEMBLY

4410926 SIDE DRESS DISC SEALER 14.5 INCH ARM HD

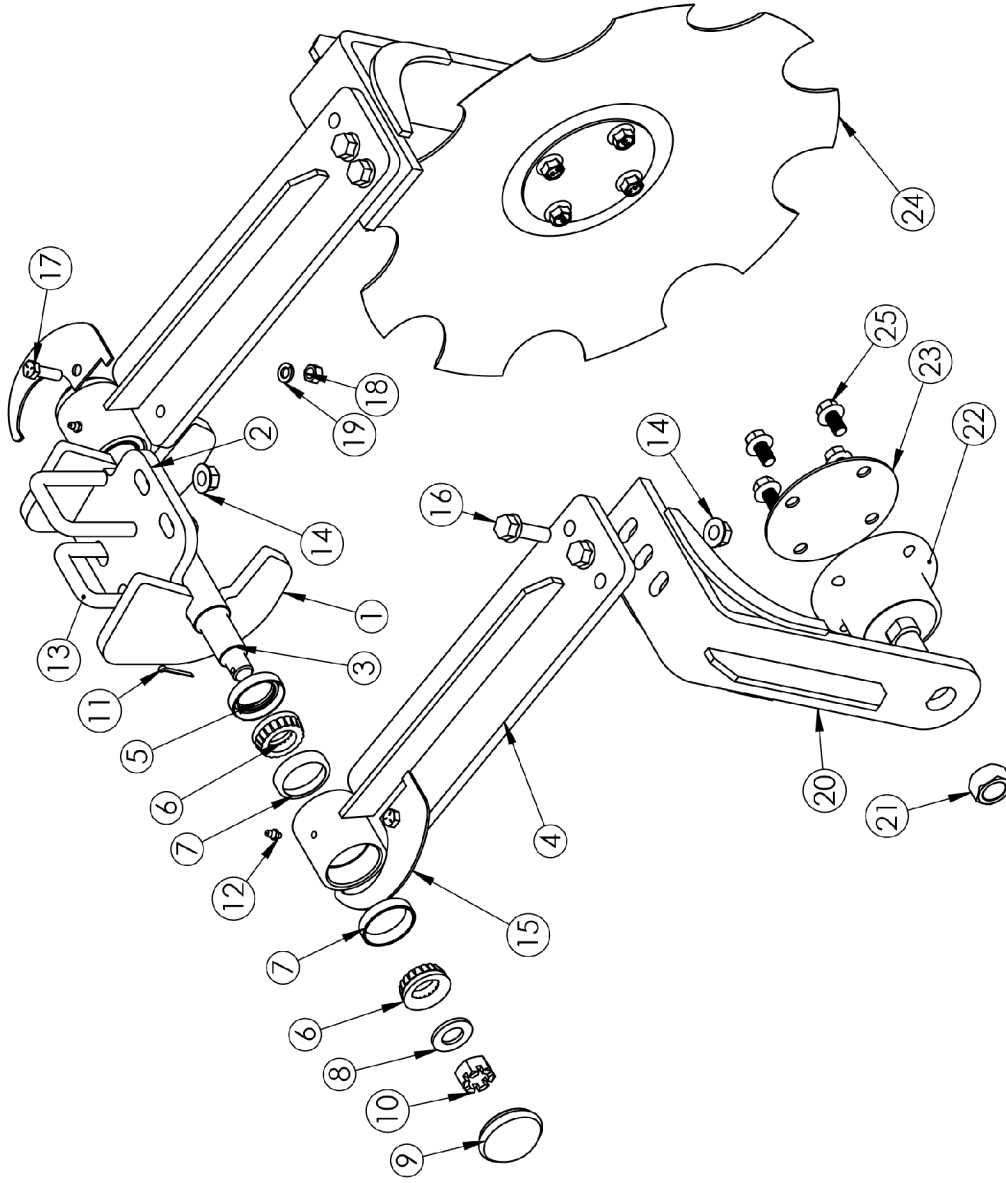

4410926

#	PART NUMBER	DESCRIPTION	QTY.
1	4435857	SIDE PLATE, LONG ARM, HD	2
2	4435858	5X6 MOUNTING PLATE, LONG ARM, HD	1
3	4435855	SPINDLE, LONG ARM, HD	1
4	4420581	PIVOT ARM, HD, LONG	2
5	4440815	SEAL, HD DISC SEALER, 1.372 X 1.979 X .432	2
6	4440816	BEARING CONE, HD DISC SEALER	4
7	4440817	BEARING CUP, HD DISC SEALER	4
8	158012	WASHER, 3/4", 3/4 SAE FLAT WASHER	2
9	4440814	DUST CAP, 2" HD DISC SEALER	2
10	158003	NUT, SLOTTED, 3/4-16, 3/4-16 SLIT HEX NUT	2
11	150409	COTTER PIN	2
12	151222	GREASE FITTING	2
13	4440788	U-BOLT, 2 X 2.5 X .5 NC, SQUARE HEAD	2
14	158007	FLANGE NUT, .5 NC	8
15	4435859	HD CAP RETAINER	2
16	158006	FLANGE BOLT, .5 X 1.75 NC, G.5	4
17	151805	BOLT, .375 X 1.25 NC, PLTD	2
18	150005	NUT, .375 NC, PLTD	2
19	150248	LOCK WASHER, .375, SS	2
20	4421749	HUB BRACKET, WELDMENT, HD, UNIT HUB	2
21	158311	NUT, CENTER LOCK, M22-1.5 CL 8.8, ZINC	2
22	4441760	HUB, UNIT BEARING, DISC SEALER	2
23	4431391	HUB CAP	2
24	4440785	BLADE, 18 INCH NOTCHED	2
25	158312	FLANGE BOLT, M12-1.25 X 20, GR 10.9, ZINC	8

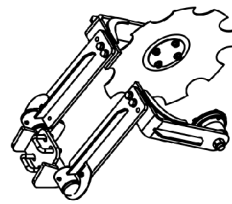

UNLESS OTHERWISE SPECIFIED TOLERANCES TO BE:
 ANGLES: ± 1.0°
 FRACTIONS < 6": ± 1/32, > 6": ± 1/16
 X.X: ± 0.06
 X.XX: ± 0.03
 X.XXX: ± 0.005

DRAWN BY: Tyler Jackson
 CHECKED BY:
 PRINT DATE: 4/10/2024
 CONFIG: Default
 COMMENTS:

Dalton
 THE USA
 A G P R O D U C T S
 602 E. VAN BUREN ST., LENOX, IA 50851
 DWG: 4410926

SIDE DRESS DISC SEALER 14.5 IN ARM HD
 SIZE: A
 SHEET TITLE: Sheet1
 SCALE: 1:24
 REV: 0
 SHEET 1 OF 1

PROPRIETARY AND CONFIDENTIAL
 THE INFORMATION CONTAINED IN THIS DRAWING IS THE SOLE PROPERTY OF DALTON AG. ANY REPRODUCTION IN PART OR AS A WHOLE WITHOUT THE WRITTEN PERMISSION OF DALTON AG IS PROHIBITED.

C:\SOLIDWORKS Data\EPDM_Vault\Row Units\Disc Sealer\DS ASSEMBLY\

5 4 3 2 1

STANDARD EDGE SHANK AND KNIVES

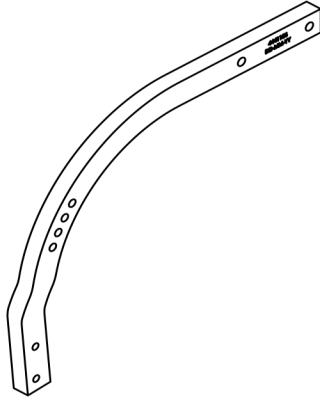

4441156 EDGE BENT SHANK



4440779 KNIFE, STANDARD W (1) .375 TUBE



4440795 KNIFE, STANDARD W (1) .375 TUBE, (1) .75 TUBE



4440890 KNIFE, MINI MOLE W (1) .375 TUBE



4420660 KNIFE, MINI MOLE W (1) .375 TUBE, (1) .75 TUBE



4440781 KNIFE, MOLE W (1) .375 TUBE



4440794 KNIFE, MOLE W (1) .375 TUBE, (1) .75 TUBE

DRAWN BY	RICH SMOTHERS	5/4/2018
CHECKED BY		
PRINT DATE		2/4/2025
CONFIG.	Default	



PROPRIETARY AND CONFIDENTIAL
 THE INFORMATION CONTAINED IN THIS DRAWING IS THE SOLE PROPERTY OF DALTON AG. ANY REPRODUCTION IN PART OR AS A WHOLE WITHOUT THE WRITTEN PERMISSION OF DALTON AG IS PROHIBITED.

COMMENTS:

DWG: STANDARD EDGE SHANK AND KNIVES

SIZE	SHEET TITLE:	REV
A	Sheet1	A

FOR PARTS, CALL 1.800.342.7498

SCALE: 1:12 SHEET 1 OF 1

4410920 SPRING LOAD 6X6 EDGE BENT W/ COULTER

ITEM NO.	PART NUMBER	DESCRIPTION	QTY.
1	4421874	PIVOT MOUNT EDGE BENT V3	1
2	641480	SPRING	1
3	150011	NUT, .625 NC, LOCKING, PLTD	4
4	4440453	BOLT .625 X 3.5 NC GRD 8 PLTD	2
5	188082	NUT, .625 NC, CENTERLOCK, PLTD	2
6	SLSC 4440813	SPRING BOLT .75 NF X 14.75	1
7	4435889	SPRING BOLT ROCKER STOP, EDGE BENT	1
8	158001	JAM NUT, .75 NF	1
9	4420280	SPRING CAP, MACHINED	1
10	158000	NUT, .75 NF	1
11	4441156	EDGE BENT SHANK	1
12	4441105	COULTER SHAFT CLAMP	2
13	152236	BOLT .5 X 3.5 NC, G5	4
14	150220	FLAT WASHER, .5 PLTD	4
15	150218	LOCK WASHER, .5 PLTD	4
16	150008	NUT, .5 NC, GR 5, PLTD	4
17	150223	WASHER, .625", .625 SAE FLAT WASHER	4
18	4421855	SHANK ROCKER, 6X6, V2	1
19	151222	GREASE FITTING	1
20	4432914	PIN, 1 X 7.25, HEADLESS	1
21	4441725	ROLL PIN, 7/16" X 1.5", ZINC PLATED	1
22	4441083	U-BOLT, .625X6.125X8 SQUARE	2
23	4431600	SPACER WASHER	5
24	4431598	URETHANE SPRING	4

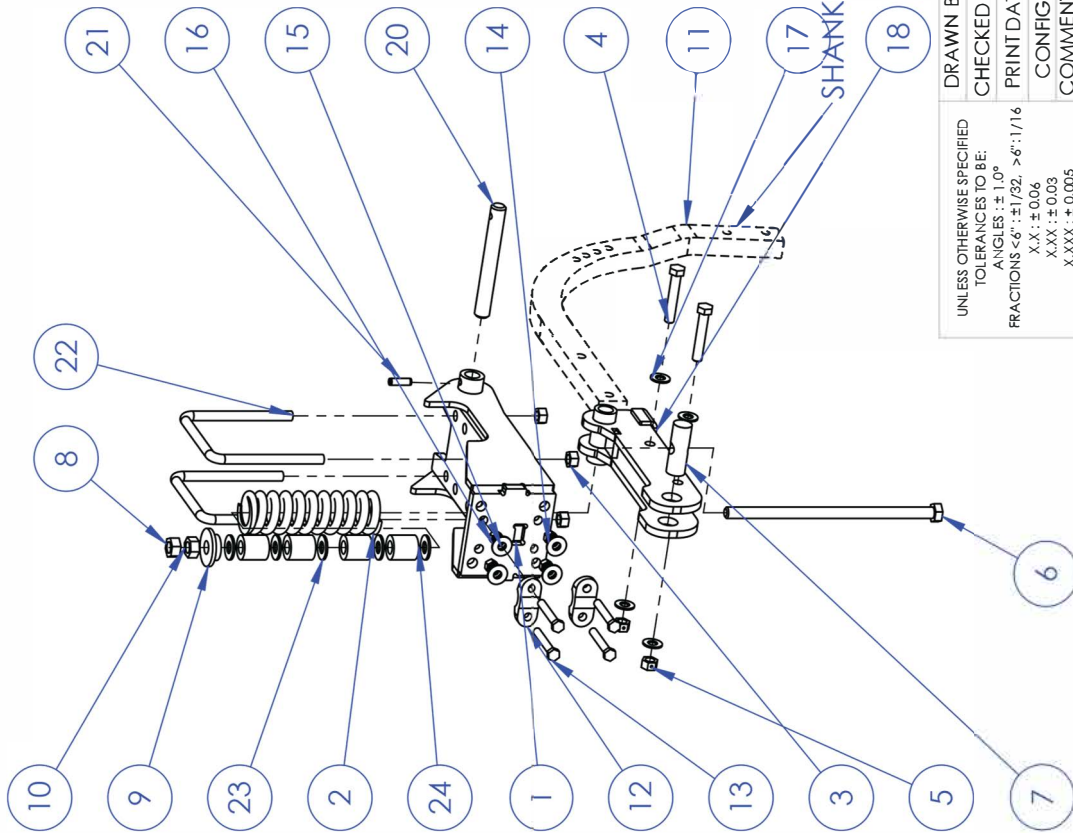

SHANK NOT PART OF PACKAGE

UNLESS OTHERWISE SPECIFIED TOLERANCES TO BE: ANGLES : ± 1.0° FRACTIONS < 6" : ± 1/32, > 6" : 1/16 X.X : ± 0.06 X.XX : ± 0.03 X.XXX : ± 0.005	DRAWN BY: Donald Sundberg CHECKED BY: PRINT DATE: 7/2/2024 CONFIG: EXPLODED COMMENTS:	DWG: 4410920 SPRING LOAD 6X6, EDGE BENT W COULTER SIZE SHEET TITLE: MOUNTS, V3 Sheet1 REV 0	SCALE: 1:12 SHEET 1 OF 2
--	---	---	-----------------------------

FOR PARTS, CALL 1.800.342.7498

PROPRIETARY AND CONFIDENTIAL
 THE INFORMATION CONTAINED IN THIS DRAWING IS THE SOLE PROPERTY OF DALTON AG. ANY REPRODUCTION IN PART OR AS A WHOLE WITHOUT THE WRITTEN PERMISSION OF DALTON AG IS PROHIBITED.

4410920 SPRING LOAD 6X6 EDGE BENT W/ COULTER CONT.

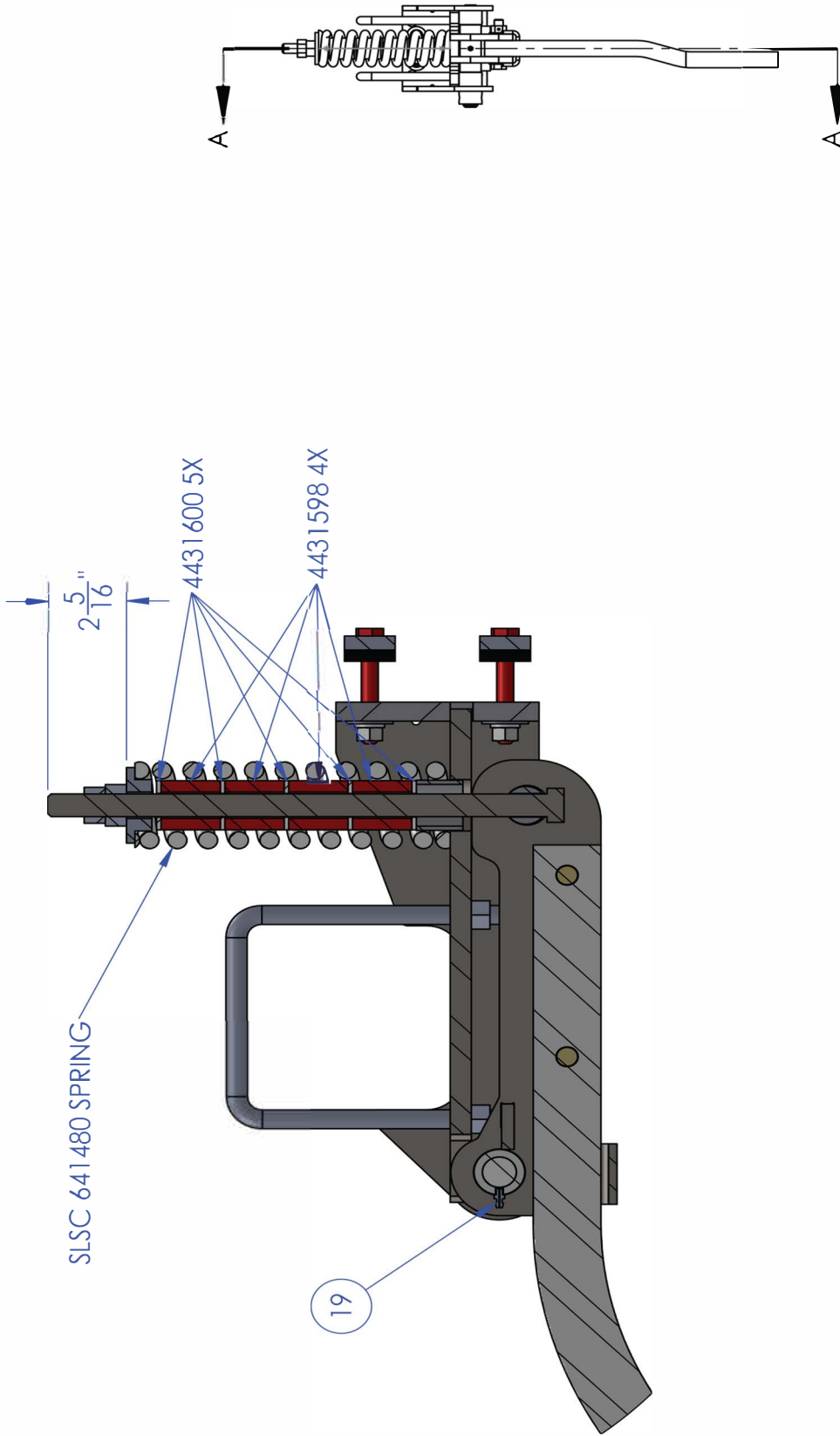

DWG: 4410920

SPRING LOAD 6X6, EDGE BENT W COULTER

SIZE SHEET TITLE: MOUNTS; V3
 Sheet2 REV 0

SCALE: 1:12 SHEET 2 OF 2

DRAWN BY	Donald Sundberg	4/2/2024
CHECKED BY		
PRINT DATE	7/2/2024	
CONFIG.	EXPLODED	
COMMENTS:		

UNLESS OTHERWISE SPECIFIED
 TOLERANCES TO BE:
 ANGLES: ± 1.0°
 FRACTIONS <6": ± 1/32; >6": .1/16
 X.X: ± 0.06
 X.XX: ± 0.03
 X.XXX: ± 0.005

SECTION A-A
 SCALE 1 : 5

PROPRIETARY AND CONFIDENTIAL
 THE INFORMATION CONTAINED IN THIS DRAWING IS THE SOLE PROPERTY OF DALTON AG. ANY REPRODUCTION IN PART OR AS A WHOLE WITHOUT THE WRITTEN PERMISSION OF DALTON AG IS PROHIBITED.

FOR PARTS, CALL 1.800.342.7498		5	4	3	2	1
--------------------------------	--	---	---	---	---	---

GROVE COULTER ASSEMBLY

B.O.M FOR COULTER ASSEMBLY

ITEM NO.	PART #	DESCRIPTION	QTY.
1	GC3000	Cast Coultter Knuckle	1
2	GC3005	Nylon Shaft Bushing	2
3	GC3010	Nylon Knuckle Bushing	1
4	GC3105	Lock Collar	1
5	GC4075	5/8-11x1 Sq Hd Set Pt	1
6	GC2005	Main Body Assembly	1
7	GC3035	1,200# Coultter Hub	1
8	GC5005	Dust Cap Keeper	1
9	GC3070	Spring Rod	1
10	GC3060	Nylon Spring Bushing	1
11	GC3055	Spring Bolt	1
12	GC3065	Spring Nut	2
13	GC3075	Spring	1
14	GC3080	Spring Alignment Casting	1
15	GC3085	Spring Lock Nut	1
16	GC3090	Washer	1
17	G905942	Cotter Pin	1
18	GC3095-	Attachment Arm	1
19	GC3102	Knife Bracket	1
20	GC5010	Knife	1
21	GC3205	Injector Mount	1

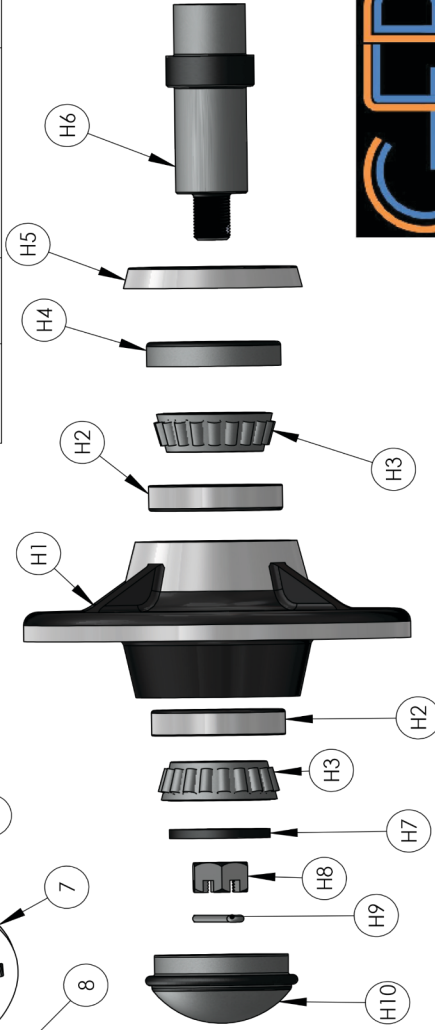
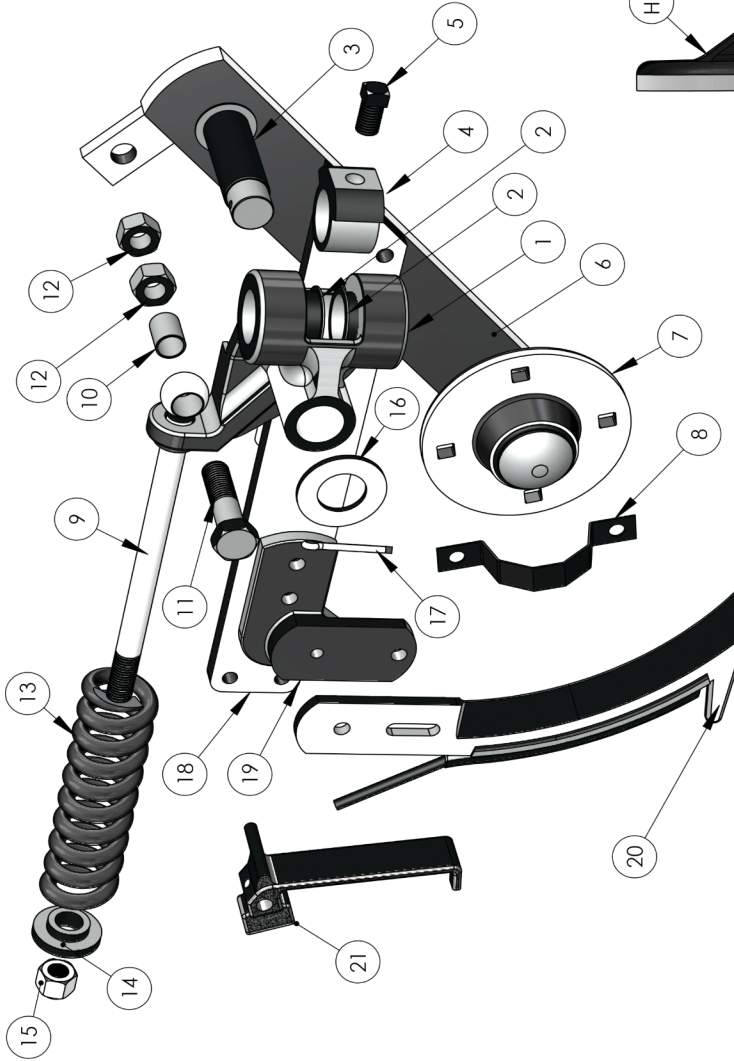

B.O.M FOR COULTER HUB ASSEMBLY

PART #	ITEM NO.	DESCRIPTION	QTY.
G120-	H1	1,200# COULTER HUB	1
G910257	H2	INNER/OUTER CUP-(LM67010)	2
G910259	H3	INNER OUTER CONE-(LM67048)	2
GC3045	H4	COULTER SEAL	1
GC3050	H5	GRASS WRAP	1
GC3020	H6	COULTER SPINDLE	1
G913611	H7	WASHER	1
G912954	H8	SPINDLE NUT	1
G905936	H9	COTTER PIN	1
G909970	H10	DUST CAP	1



YETTER 20" EXTREME COULTER ASSEMBLY 2995-153

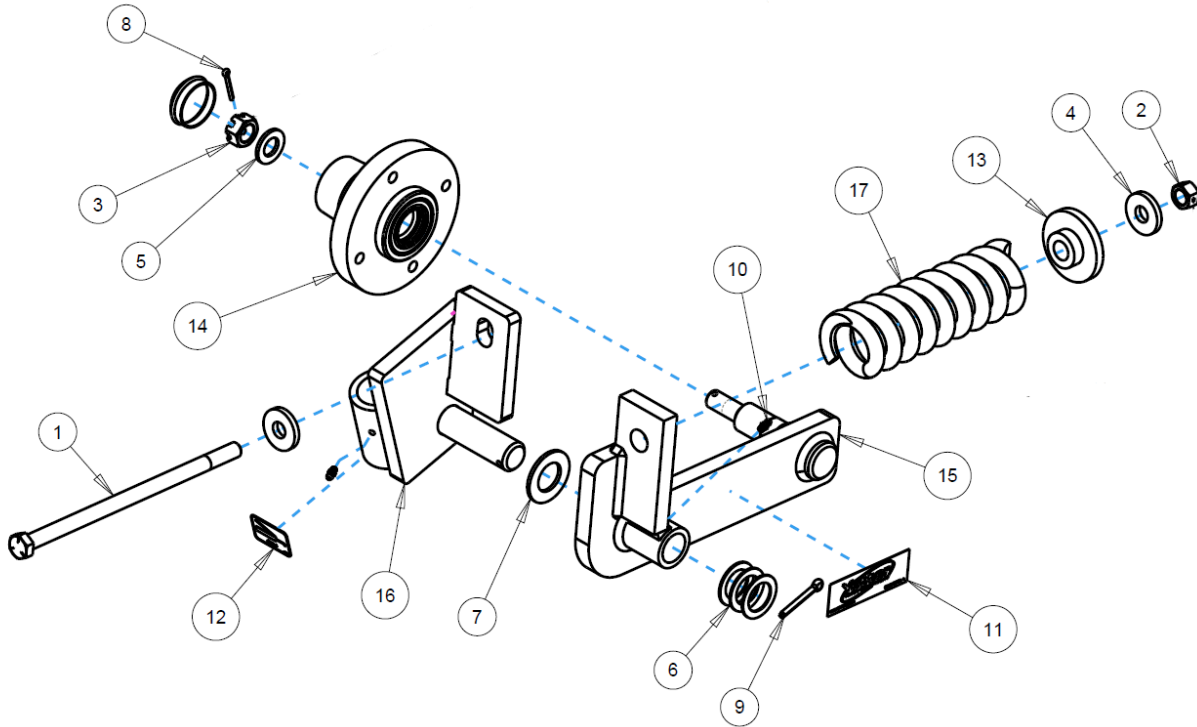

ITEM	PART NO.	DESCRIPTION	QTY
1	2502-337	5/8-11 X 12 HHCS GRADE 5	1
2	2520-459	5/8-11 LOCK NUT GRADE B	1
3	2520-503	3/4-16 SLOTTED HEX NUT GRADE 2	1
4	2526-449	5/8 FLAT WASHER 1/4" THICK	2
5	2526-504	3/4 SAE FLAT WASHER	1
6	2526-561	1-17/64 ID X 1-7/8 OD X 14 GAUGE MACHINE WASHER	3
7	2526-562	1-17/64 ID X 2-1/4 OD X 10 GAUGE MACHINE WASHER	1
8	2531-109	5/32 X 1-1/4 COTTER PIN	1
9	2531-125	1/4 X 1-3/4 COTTER PIN	1
10	2533-110	1/4-28 LUBE FITTING STRAIGHT SELF-TAP	2
11	2565-162	YETTER DECAL	1
12	2565-832	GREASE DAILY DECAL	1
13	2986-405	SPRING BUSHING	1
14	2995-138	633 HUB ASSEMBLY	1
	2533-110	1/4-28 LUBE FITTING STRAIGHT SELF-TAP	1
	2550-012	OUTER BEARING CONE LM11949	1
	2550-013	OUTER BEARING CUP LM11910	1
	2550-027	INNER BEARING CONE LM67048	1
	2550-029	INNER BEARING CUP LM67010	1
	2995-400	HUB	1
	2995-401	SEAL CR-14975	1
	2995-402	DUST CAP	1
15	2995-246	ARM	1
16	2995-254-RH	RIGHT HAND PIVOT	1
17	2995-403	SPRING	1

YETTER 24" EXTREME COULTER ASSEMBLY

2995-149

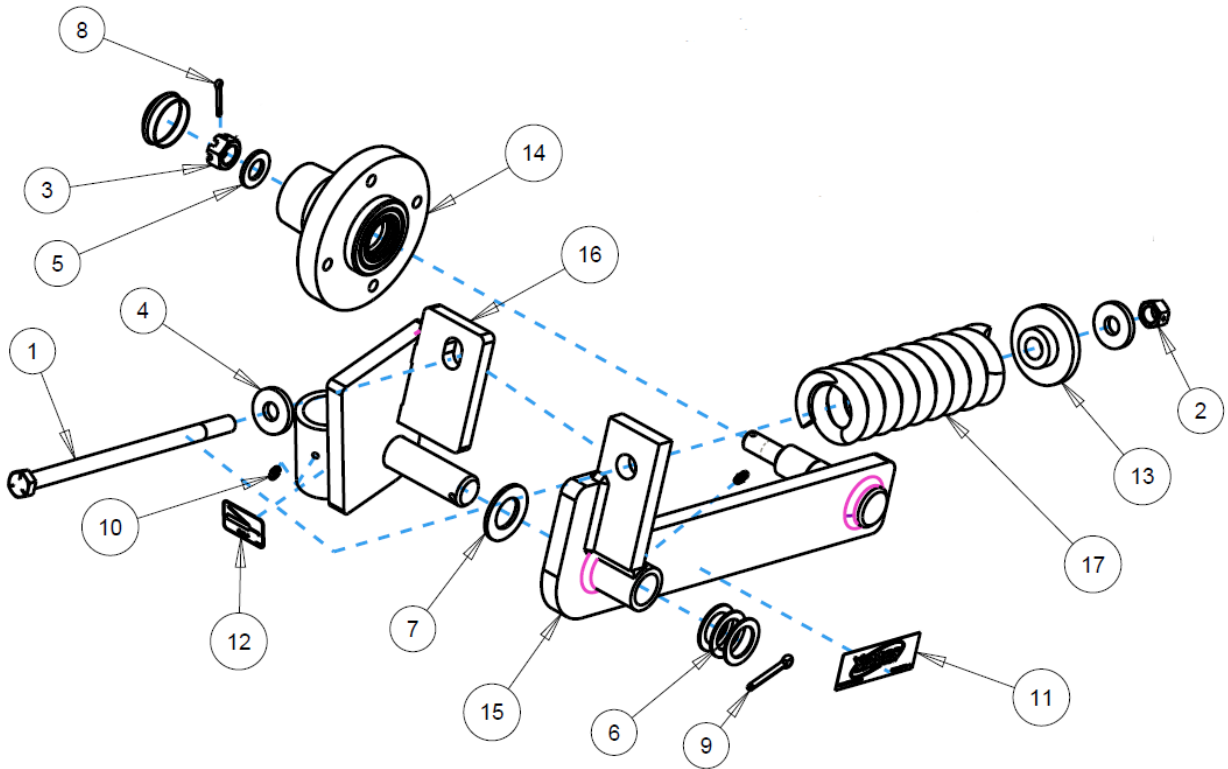

ITEM	PART NO.	DESCRIPTION	QTY
1	2502-337	5/8-11 X 12 HHCS GRADE 5	1
2	2520-459	5/8-11 LOCK NUT GRADE B	1
3	2520-503	3/4-16 SLOTTED HEX NUT GRADE 2	1
4	2526-449	5/8 FLAT WASHER 1/4" THICK	2
5	2526-504	3/4 SAE FLAT WASHER	1
6	2526-561	1-17/64 ID X 1-7/8 OD X 14 GAUGE MACHINE WASHER	3
7	2526-562	1-17/64 ID X 2-1/4 OD X 10 GAUGE MACHINE WASHER	1
8	2531-109	5/32 X 1-1/4 COTTER PIN	1
9	2531-125	1/4 X 1-3/4 COTTER PIN	1
10	2533-110	1/4-28 LUBE FITTING STRAIGHT SELF-TAP	2
11	2565-162	YETTER DECAL	1
12	2565-832	GREASE DAILY DECAL	1
13	2986-405	SPRING BUSHING	1
14	2995-138	633 HUB ASSEMBLY	1
	2533-110	1/4-28 LUBE FITTING STRAIGHT SELF-TAP	1
	2550-012	OUTER BEARING CONE LM11949	1
	2550-013	OUTER BEARING CUP LM11910	1
	2550-027	INNER BEARING CONE LM67048	1
	2550-029	INNER BEARING CUP LM67010	1
	2995-400	HUB	1
	2995-401	SEAL CR-14975	1
	2995-402	DUST CAP	1
15	2995-248	ARM	1
16	2995-254-RH	RIGHT HAND PIVOT	1
17	2995-403	SPRING	1

YETTER 20" & 24" EXTREME HUB BREAKDOWN 2995-138

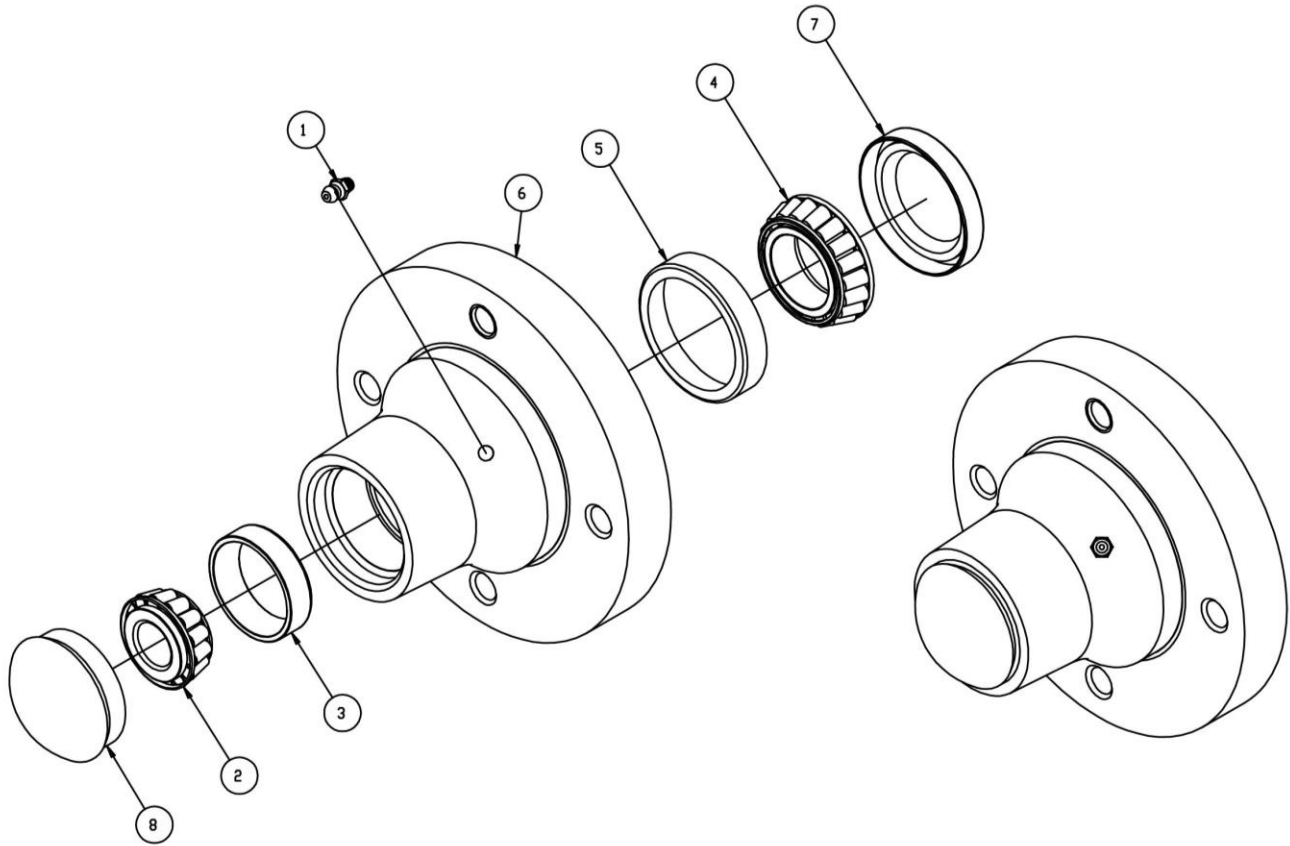

ITEM	PART NO	DESCRIPTION	QTY
1	2533-110	1/4-28 ZERK STRAIGHT SELF-TAP	1
2	2550-012	CONE W.G. (LM11949)	1
3	2550-013	CUP W.G. (LM11910)	1
4	2550-027	CONE, LM67048	1
5	2550-029	CUP, LM67010	1
6	2995-400	633 HUB, MACHINED	1
7	2995-401	SEAL, CR #14975	1
8	2995-402	HUB CAP, 633 HUB	1

The American Society of Agricultural Engineers has established minimum marking recommendations for agricultural field equipment that is towed on or across public highways. These standards include:

1. Implements which obscure the rear tractor lighting; or are more than 13 ft. wide; or extend to the left or right of the tractor center by 79 in. and beyond the left or right extremity of the tractor; or extend more than 33 ft. to the rear of the tractor hitchpoint should have the following lighting to meet minimum safety standards:
 - a. One red tail lamp mounted to the rear of the implement and as far to the left as possible. This must face rearward only.
 - b. Two amber flashing lights, visible from front and rear, and as far to the left and right as possible. These should be mounted to within 16 in. of extremities and within 39 in. to 10 ft. in height.
 - c. Non-symmetrical equipment, such as moldboard plows or windrowers, extending only to the left or right may have one amber flashing light mounted to within 16 in. of the extremity.
2. Implements extending more than 4 ft. to the left of the center of the tractor should have at least one amber reflector visible to the front, located to the extreme left of the implement.
3. Implements exceeding more than 10 ft. behind the hitchpoint should have at least two amber reflectors visible from both the left and right sides. Reflectors should be spaced no more than 5 ft. apart, starting from the hitch. The rear most reflector should be positioned as far to the rear as possible.
4. Implements extending more than 4 ft. to the rear of the hitchpoint or more than 4 ft. to the left or right of the center of the tractor should have at least two red reflectors visible to the rear.

LOCATION

Dual and single lamp units can be mounted in a variety of locations and positions using the following guidelines:



1. Amber must always be mounted either the top or outer-most left or right position. It should be able to be seen from both the front or rear of the implement at all times.
2. Single lamps may be used in place of a dual lamp, if mounting is a problem.
3. If the amber lamp cannot be seen from both front and rear of the implement at the same time, a second lamp is necessary and should be positioned as far forward as possible.
4. Red is to face rearward only.

Note: All lamps can be mounted horizontally, vertically, upright or inverted. However, care should be taken to adequately protect the base from excess water buildup when inverting.

MOUNTING

All units have provisions for multiple mounting. The outermost holes will accept 1/4" machine or lag screws and will allow thru-panel bolting. The inner holes are designed to accept 1/4" lag or self-drilling screws only. Maximum length not to exceed 1" beyond panel. A 9/32" dia. hole size is recommended.

If holes are required to route wires and connectors from lamp units, a 3/4" dia. hole is recommended.

The diagram below should be used as a guide for mounting hole

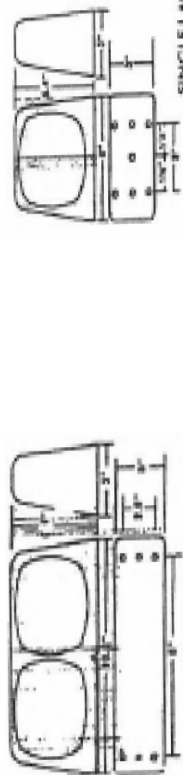

DECAL LAYOUT

ASSEMBLY

TOOLBAR - DECAL LAYOUT

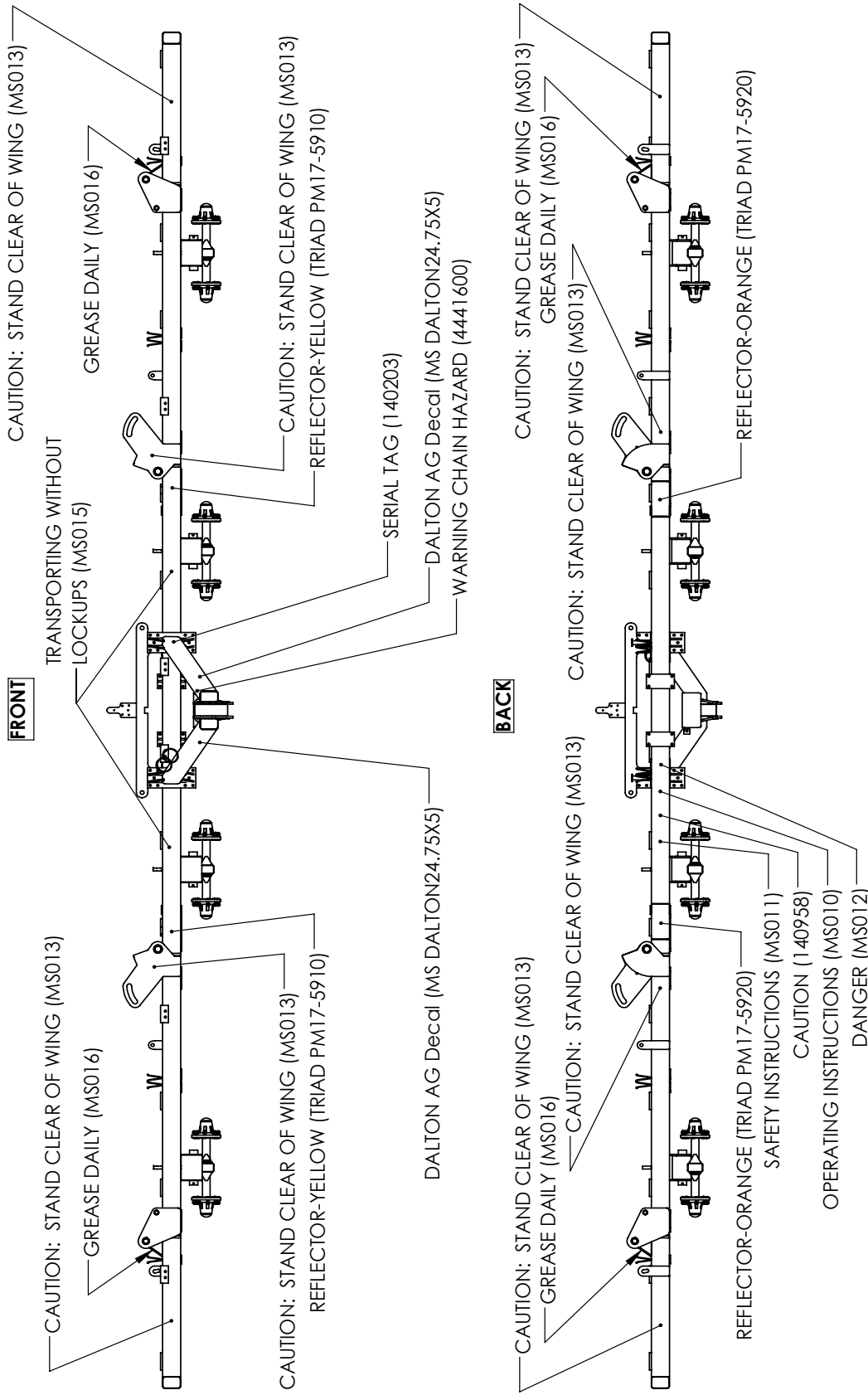

DRAWN BY	RICH SMOTHERS	6/20/2016	 <p>602 E. VAN BUREN ST., LENOX, IA 50851</p>	DWG:	TOOLBAR - DECAL LAYOUT	
CHECKED BY				SIZE	SHEET TITLE:	REV
PRINT DATE	6/3/2021			A	Sheet1	
CONFIG.	Default			SCALE:	1:48	SHEET 1 OF 1
COMMENTS:	<p>C:_epdm_vault\tool_bar\fb documents\fb manuals\</p>					
<p>PROPRIETARY AND CONFIDENTIAL THE INFORMATION CONTAINED IN THIS DRAWING IS THE SOLE PROPERTY OF DALTON AG. ANY REPRODUCTION IN PART OR AS A WHOLE WITHOUT THE WRITTEN PERMISSION OF DALTON AG IS PROHIBITED.</p>						
5	4	3	2	1		

PARTS ORDERING PROCEDURE

Your Dalton Ag dealer is interested in your new fertilizer application equipment and has the desire to help you get the most value from it. Through the help of this manual, you will find you can do some of the regular maintenance yourself. For parts and service, contact the Dalton Ag Dealership from which you purchased your fertilizer application equipment or your local Dalton Ag dealer.

When replacement parts are required, consult the applicable illustration and parts list to obtain the correct part name and number. When requesting a replacement part, always include the following information:

1. Complete Part Number
2. Description
3. Quantity Required
4. Machine and Model Number
5. Machine Serial Number - located on the topside of the frame near hitch
6. Provide complete name and address for where and how parts are to be shipped.

NOTE: Right and left hand parts and sides of the units are determined by standing at the rear and facing in the direction of forward travel.

EQUIPMENT MODEL:

EQUIPMENT SERIAL NO.:

DATE OF PURCHASE:

NAME OF DEALER:

DEALER'S PHONE NUMBER:

Thank you for your business!

NOTES

NOTES

Dalton



A G P R O D U C T S

E AN BUREN LENO IOWA