



PARTS MANUAL
DISC SEALERS & SPRING LOADS

2025



DISC SEALERS

STANDARD INDEPENDENT STYLE

PART #: 4410171

Our Standard Independent Style arms work with variable pitch on blades, which works well in no-till fields. The blades will move dirt that has been displaced back into place. The arms pivot on the 1.25" shaft with non-greasable composite bushings. The adjustable blades allow for minimum to maximum soil disturbance.

Arms are also available in off-set design

18" NOTCHED BLADES

The large 18" notched blades have a small concave shape which allows you to run the blade straighter reducing wear and tear on bearings and spindles, minimizing disc track. The variable blade pitch adjustment and three-hole design gives you the ability to adjust to your field conditions.

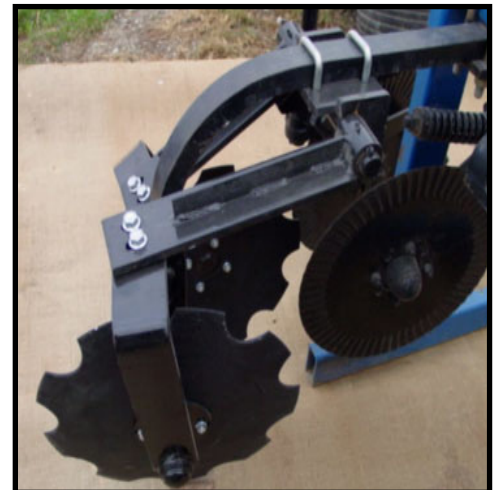

SIDE-DRESS INDEPENDENT STYLE

PART #: 4410185

Our Side-Dress Independent Style disc sealers are designed with 14.5" arms. These 18" blades are located beside the knife to reduce throwing of dirt on young plants. This unit also pivots on a 1.25" shaft with non-greasable composite bushings.

HEAVY DUTY INDEPENDENT STYLE

PART #: 4410223

Our Heavy Duty Independent style disc sealer covers better, lasts longer and is more trouble free than any other on the market today. The independent arm design and the large 18" notched blade provides better knife track coverage and keeps the trash flowing through without build-up or plugging. It also provides better coverage in uneven terrain and allows you to be more productive.

The heavy duty design is based on tapered roller bearings instead of plastic, fiber or bronze bushings. Heavier overall components and eliminations of springs increases the lifetime of our disc sealers.

Arms are also available in off-set design

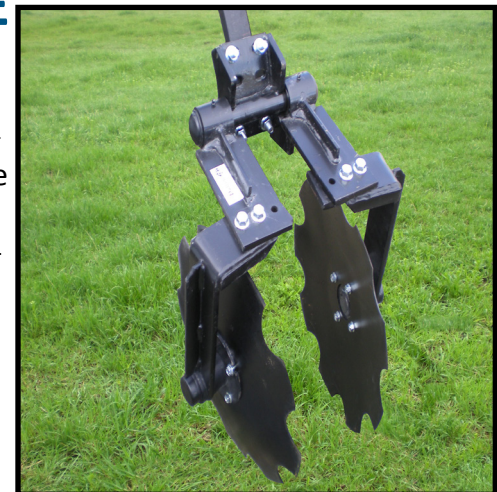

TABLE OF CONTENTS

4410171 INDEPENDENT STYLE DISC SEALER.....	1
4410171 OS INDEPENDENT STYLE WITH OFFSET ARMS.....	2
4410223 HEAVY DUTY DISC SEALER.....	3
4410223 OS HEAVY DUTY DISC SEALER WITH OFFSET ARMS.....	4
4410185 INDEPENDENT STYLE WITH 14.5" ARMS.....	5
4410926 HS SIDE DRESS DISC SEALER.....	6
4410190 INDEPENDENT STYLE, CENTER SEALER WITH 14" NOTCHED BLADES.....	7
4410925 EDGE SPRING LOADED DISC SEALER.....	8
4410934 HCS GEN 2 DISC SEALER.....	9
4410934- OS HCS GEN 2 DISC SEALER.....	10
4410912 EDGE HD DISC SEALER.....	11
4410912-OS EDGE HD DISC SEALER.....	12
S1264SL SPRING LOADED SHANK CLAMP, 4 X 6.....	13
S1266SL SPRING LOADED SHANK CLAMP, 6 X 6.....	14
4410920 SPRING LOAD 6X6 EDGE BENT.....	15,16
PARTS ORDERING PROCEDURE.....	17
LIMITED WARRANTY STATEMENT.....	18

4410171, STANDARD DISC SEALER

INDEPENDENT STYLE

#	PART NUMBER	QTY.
1	4410171 INDEPENDENT STYLE Δ	1
2	4410174 UPPER MOUNTING BRACKET □	1
3	DS 4420271 SHANK MOUNTING BRACKET	1
4	DS 4410256 PIVOT ARM W BUSHING, LH	1
5	4440857 BUSHING, COMPOSITE	2
6	DS 4410255 PIVOT ARM W BUSHING, RH	1
7	150251 FLAT WASHER, 1.25 ID x 1.875 OD	2
8	101.689 SPRING PIN .375x2	2
9	4420277 HUB ASSEMBLY, STD □	2
10	DS 4420273 HUB BRACKET, STD, WELDMENT	1
11	DS 4420201 SPINDLE HUB, STD, WELDMENT	1
12	151222 GREASE ZERK, .25 SELF TAPPING	1
13	4440704 SEAL	1
14	4440702 BEARING	2
15	4440703 RACE	2
16	150224 FLAT WASHER, .625	1
17	4440737 SLOTTED NUT,	1
18	150406 COTTER PIN, .125 x 2	1
19	QDS909923 DUST CAP, 1.75	1
20	151835 CARRIAGE BOLT .375x.75 NC PLTD	8
21	DS 4440785 BLADE, 18 INCH NOTCHED	2
22	158005 FLANGE NUT, .375 NC	8
23	158006 FLANGE BOLT, .5 NC x 1.75, G5	4
24	158007 FLANGE NUT, .5 NC	8
25	4440788 U-BOLT, 2 x 2.5 x .5 NC, SQUARE HEAD	2

ALL QUANTITIES ARE PER ROW UNIT

4450048 - STANDARD DISC SEALER REBUILD KIT
 -INCLUDES (2) BEARINGS, (2) RACES, AND (1) SEAL

4410171 INDEPENDENT STYLE

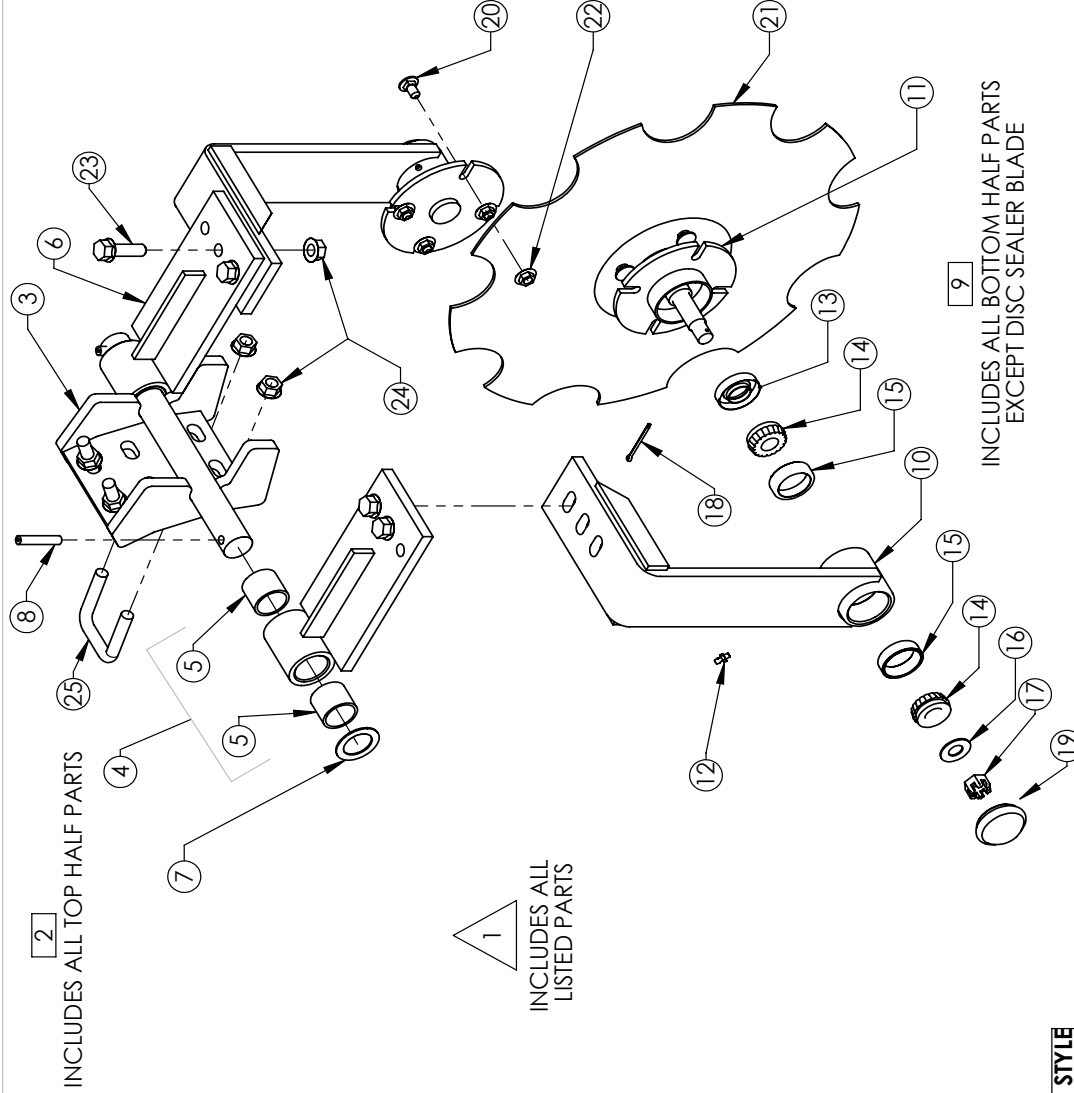

PROPRIETARY AND CONFIDENTIAL
 THE INFORMATION CONTAINED IN THIS DRAWING IS THE SOLE PROPERTY OF DALTON A.G. ANY REPRODUCTION IN PART OR AS A WHOLE WITHOUT THE WRITTEN PERMISSION OF DALTON A.G IS PROHIBITED.

DRAWN BY	RICH SMOTHERS	10/21/2013
CHECKED BY		
PRINT DATE	6/28/2016	
CONFIG.	EXP VIEW	
COMMENTS:	4410171 INDEPENDENT STYLE	
DWG:	INDEPENDENT STYLE	
SIZE	A	B.O.M.
SHEET TITLE:	REV	
SCALE:	1:7	SHEET 1 OF 1

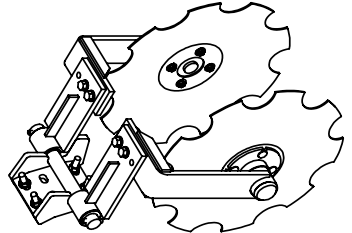

4410171 OS, STANDARD DISC SEALER WITH OFFSET ARMS

OS INDEPENDENT STYLE WITH OFFSET ARMS

#	PART NUMBER	Q.
1	4410171 OS INDEPENDENT STYLE WITH OFFSET ARMS	△
2	DS 4410174 OS UPPER MOUNTING BRACKET, OFFSET	□
3	DS 4420271 SHANK MOUNTING BRACKET	1
4	DS 4410256 PIVOT ARM W BUSHING, LH	1
5	4440857 BUSHING, COMPOSITE	2
6	150251 FLAT WASHER, 1.25 ID x 1.875 OD	2
7	101689 SPRING PIN, .375x2	2
8	DS 4410303 PIVOT ARM, LONG, RH	1
9	4420277 HUB ASSEMBLY, STD	□
10	DS 4420273 HUB BRACKET, STD, WELDMENT	1
11	DS 4420201 SPINDLE HUB, STD, WELDMENT	1
12	151222 GREASE ZERK, .25 SELF TAPPING	1
13	4440704 SEAL	1
14	4440702 BEARING	2
15	4440703 RACE	2
16	150224 FLAT WASHER, .625	1
17	4440737 SLOTTED NUT,	1
18	150406 COTTER PIN, .125 x 2	1
19	QDS909923 DUST CAP, 1.75	1
20	151835 CARRIAGE BOLT, .375x.75 NC PLTD	8
21	DS 4440785 BLADE, 18 INCH NOTCHED	2
16	158005 FLANGE NUT, .375 NC	8
23	158006 FLANGE BOLT, .5 NC x 1.75, G-5	4
24	158007 FLANGE NUT, .5 NC	8
25	4440788 U-BOLT, 2 x 2.5 x .5 NC, SQUARE HEAD	2

ALL QUANTITIES ARE PER ROW UNIT

**** TO REVERSE OFFSET ****

**USE 4410304 PIVOT ARM, LONG, LH AND
4410255 PIVOT ARM W BUSHING, RH**

**4450048 - STANDARD DISC SEALER REBUILD KIT
-INCLUDES (2) BEARINGS, (2) RACES, AND (1) SEAL**

4410171 OS INDEPENDENT STYLE WITH OFFSET ARMS

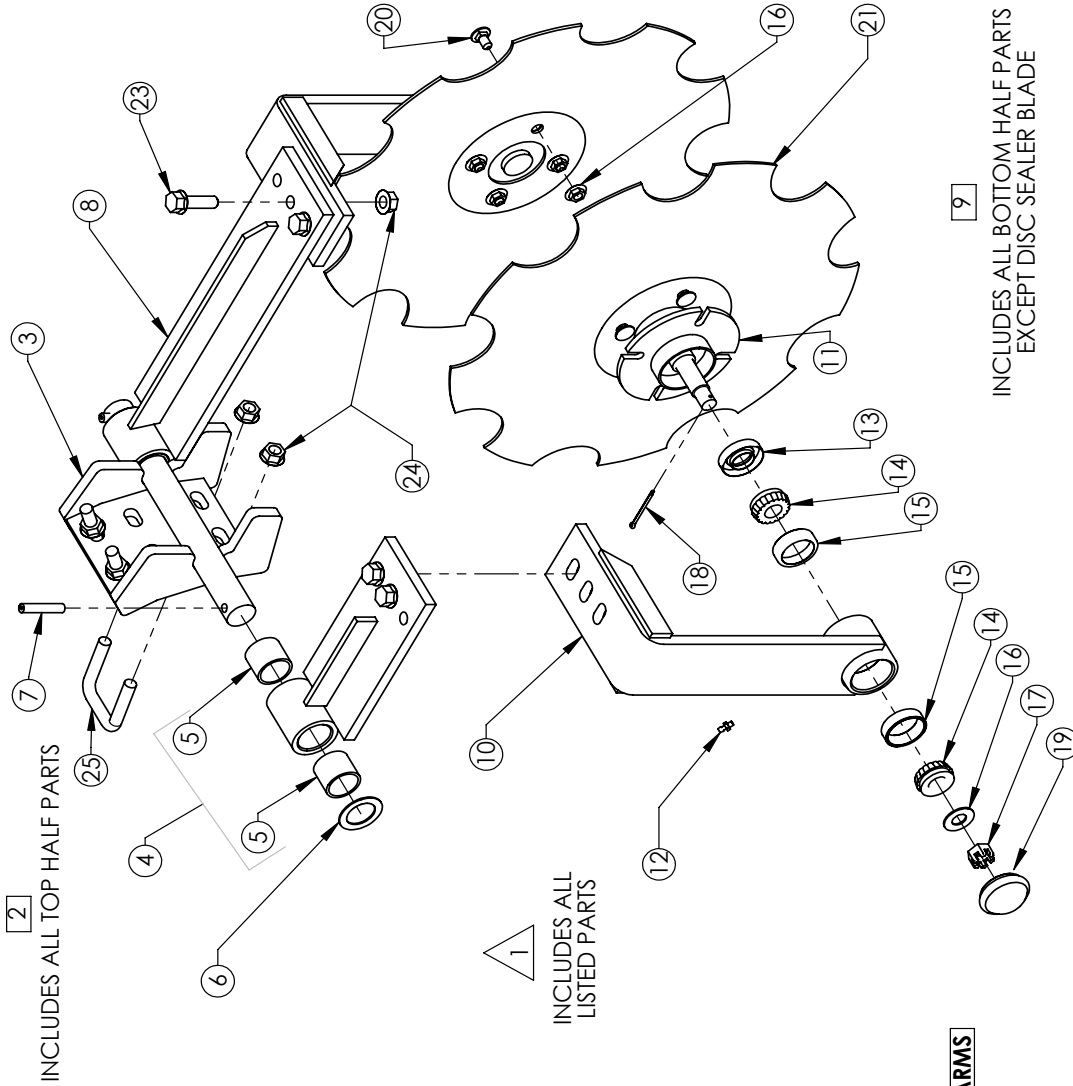

INCLUDES ALL TOP HALF PARTS
INCLUDES ALL BOTTOM HALF PARTS
EXCEPT DISC SEALER BLADE

DRAWN BY RICH SMOTHERS 10/21/2013

CHECKED BY

PRINT DATE 6/28/2016

CONFIG. EXP VIEW

COMMENTS:

**4410171 OS INDEPENDENT STYLE
WITH OFFSET ARMS**

PROPRIETARY AND CONFIDENTIAL
THE INFORMATION CONTAINED IN THIS
DRAWING IS THE SOLE PROPERTY OF
DALTON A.G. ANY REPRODUCTION IN
PART OR AS A WHOLE WITHOUT THE
WRITTEN PERMISSION OF DALTON A.G. IS
PROHIBITED.



DWG: OS INDEPENDENT STYLE WITH OFFSET ARMS

SIZE SHEET TITLE: B.O.M.

REV A

SCALE: 1:7 SHEET 1 OF 1

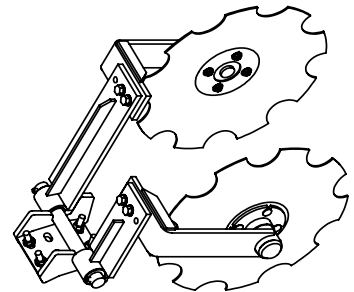

4410223, HEAVY DUTY DISC SEALER

HD DISC SEALER

#	PART NUMBER	Q
1	4410223 HD DISC SEALER Δ	1
2	4420310 HD UPPER MOUNTING ASSEMBLY □	1
3	DS 4420302 UPPER MOUNTING BRACKET, HD, WELDMENT	1
4	DS 4420303 PIVOT ARM, HD	2
5	4440815 SEAL	2
6	4440816 BEARING	4
7	4440817 RACE	4
8	158003 SLOTTED NUT, .75 NC	2
9	158012 SPINDLE WASHER, .75	2
10	150409 COTTER PIN, .125 x 1.5, PLAIN	2
11	4440814 DUST CAP, 2 INCH	2
12	158007 FLANGE NUT, .5 NC	4
13	151222 GREASE ZERK, .25 SELF TAPPING	2
14	4440788 U-BOLT, 2 x 2.5 x .5 NC, SQUARE HEAD	2
15	158006 FLANGE BOLT, .5 NC x 1.75, G5	4
16	158007 FLANGE NUT, .5 NC	4
17	4420309 HD HUB ASSEMBLY □	1
18	DS 4420304 HUB BRACKET, WELDMENT, HD	1
19	DS 4420305 SPINDLE HUB, HD, WELDMENT	1
20	150409 COTTER PIN, .125 x 1.5, PLAIN	1
21	4440814 DUST CAP, 2 INCH	1
22	151222 GREASE ZERK, .25 SELF TAPPING	1
23	4440817 RACE	2
24	4440816 BEARING	2
25	4440815 SEAL	1
26	158012 SPINDLE WASHER, .75	1
27	DS 4440785 BLADE, 18 INCH NOTCHED	1
28	158005 FLANGE NUT, .375 NC	4
29	158002 SLOTTED NUT, .75 NC THIN	1
30	158004 FLANGE BOLT, .375 NC x .75, G5	4

ALL QUANTITIES ARE PER ROW UNIT

4450049 - HD DISC SEALER REBUILD KIT
 -INCLUDES (2) BEARINGS, (2) RACES, AND (1) SEAL

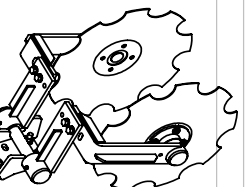

4410223 HD DISC SEALER

PROPRIETARY AND CONFIDENTIAL
 THE INFORMATION CONTAINED IN THIS DRAWING IS THE SOLE PROPERTY OF DALTON A.G. ANY REPRODUCTION IN PART OR AS A WHOLE WITHOUT THE WRITTEN PERMISSION OF DALTON A.G IS PROHIBITED.

5

4

3

2

1

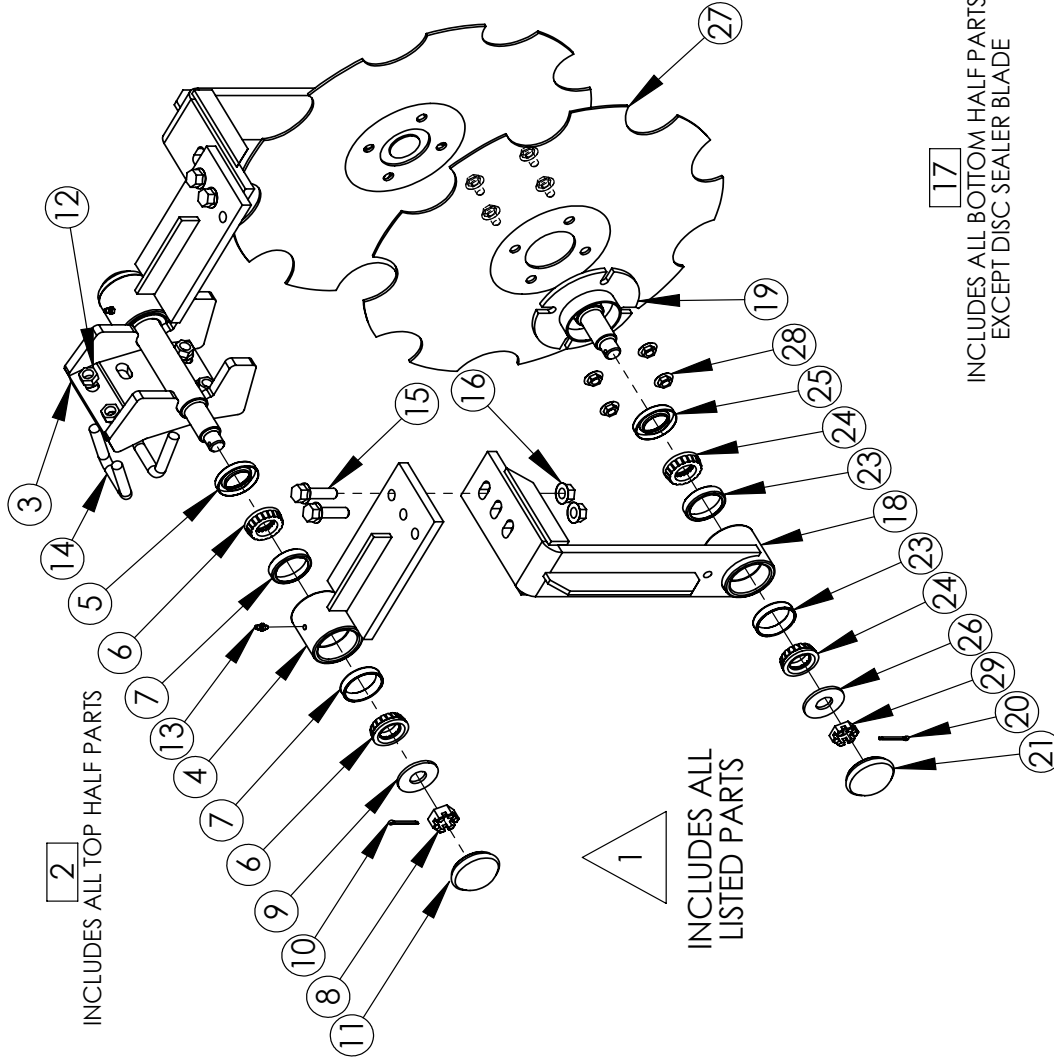

17
 INCLUDES ALL BOTTOM HALF PARTS EXCEPT DISC SEALER BLADE

DRAWN BY	RICH SMOTHERS	4/28/2009
CHECKED BY		
PRINT DATE	6/28/2016	
CONFIG.	EXPLODED	
COMMENTS:		



DWG:	HD DISC SEALER
SIZE	A
SHEET TITLE:	ASSEMBLY
REV	A
SCALE:	1:8
SHEET 1 OF 1	

4410223 OS, HEAVY DUTY DISC SEALER WITH OFFSET ARMS

OS HD DISC SEALER WITH OFFSET ARMS

#	PART NUMBER	Q
1	4410223 OS HD DISC SEALER WITH OFFSET ARMS Δ	1
2	4420310 OS HD UPPER MOUNTING ASSEMBLY □	1
3	DS 4420302 UPPER MOUNTING BRACKET, HD, WELDMENT	1
4	DS 4420303 PIVOT ARM, HD	1
5	4440815 SEAL	2
6	4440816 BEARING	4
7	4440817 RACE	4
8	158003 SLOTTED NUT, .75 NC	2
9	158012 SPINDLE WASHER, .75	2
10	150409 COTTER PIN, .125 x 1.5, PLAIN	2
11	4440814 DUST CAP, 2 INCH	2
12	158007 FLANGE NUT, .5 NC	4
13	151222 GREASE ZERK, .25 SELF TAPPING	2
14	4440788 U-BOLT, 2 x 2.5 x .5 NC, SQUARE HEAD	2
15	4420581 PIVOT ARM, HD, LONG	1
16	158006 FLANGE BOLT, .5 NC x 1.75, G5	4
17	158007 FLANGE NUT, .5 NC	4
18	4420309 HD HUB ASSEMBLY □	2
19	DS 4420304 HUB BRACKET, WELDMENT, HD	1
20	DS 4420305 SPINDLE HUB, HD, WELDMENT	1
21	150409 COTTER PIN, .125 x 1.5, PLAIN	1
22	4440814 DUST CAP, 2 INCH	1
23	151222 GREASE ZERK, .25 SELF TAPPING	1
24	4440817 RACE	2
25	4440816 BEARING	2
26	4440815 SEAL	1
27	158012 SPINDLE WASHER, .75	1
28	DS 4440785 BLADE, 18 INCH NOTCHED	1
29	158005 FLANGE NUT, .375 NC	4
30	158002 SLOTTED NUT, .75 NC THIN	1
31	158004 FLANGE BOLT, .375 NC x .75, G5	4

ALL QUANTITIES ARE PER ROW UNIT

4450049 - HD DISC SEALER REBUILD KIT

-INCLUDES (2) BEARINGS, (2) RACES, AND (1) SEAL

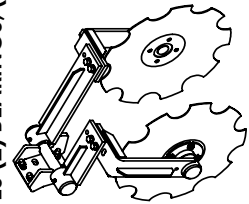

4410223 OS HD DISC SEALER WITH OFFSET ARMS

PROPRIETARY AND CONFIDENTIAL
THE INFORMATION CONTAINED IN THIS DRAWING IS THE SOLE PROPERTY OF DALTON A.G. ANY REPRODUCTION IN PART OR AS A WHOLE WITHOUT THE WRITTEN PERMISSION OF DALTON A.G. IS PROHIBITED.

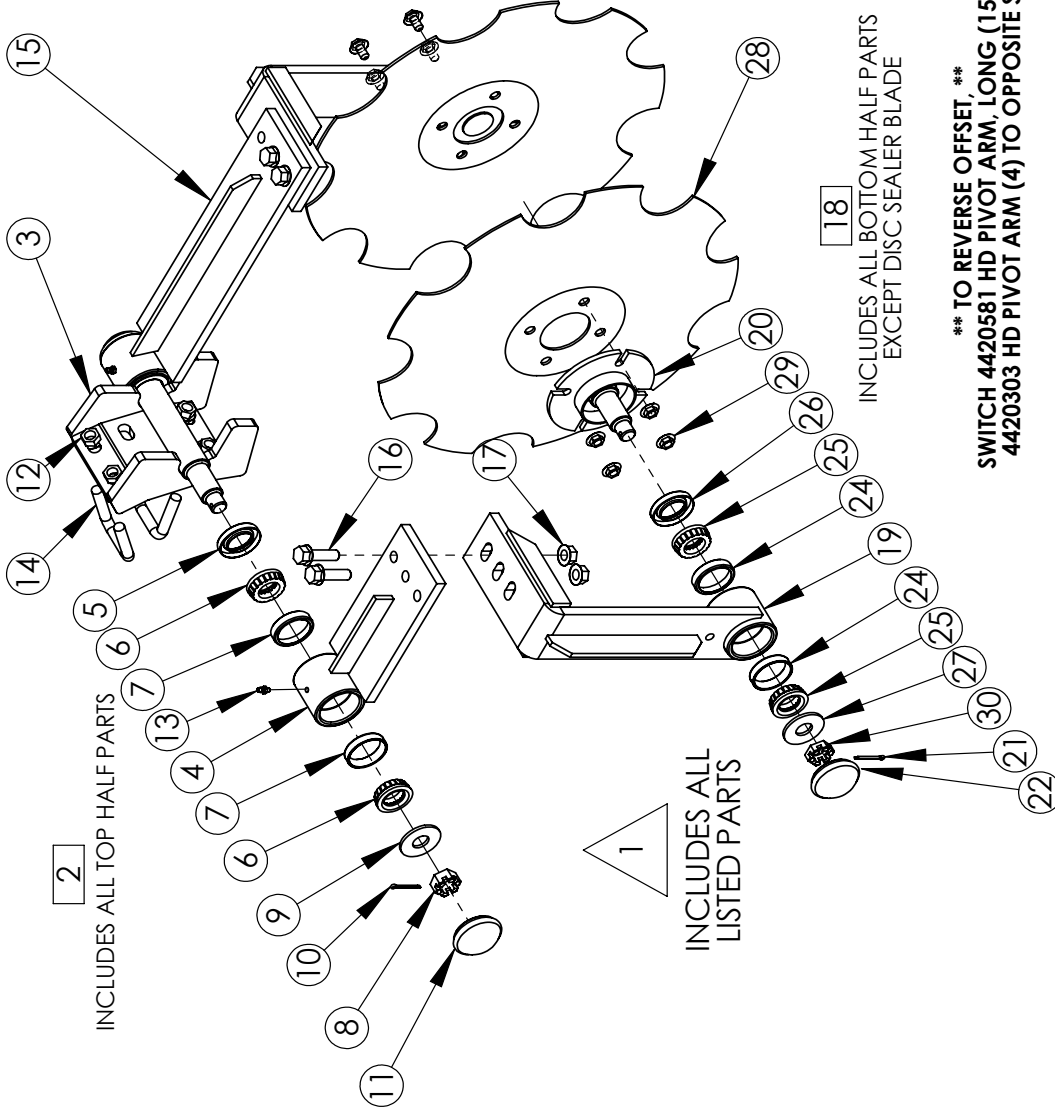

2
INCLUDES ALL TOP HALF PARTS

1
INCLUDES ALL LISTED PARTS

18
INCLUDES ALL BOTTOM HALF PARTS EXCEPT DISC SEALER BLADE

**** TO REVERSE OFFSET, **
SWITCH 4420581 HD PIVOT ARM, LONG (15) AND
4420303 HD PIVOT ARM (4) TO OPPOSITE SIDES**

DRAWN BY	RICH SMOTHERS	4/28/2009
CHECKED BY		
PRINT DATE	6/28/2016	
CONFIG.	EXPLODED	

DWG: OS HD DISC SEALER WITH OFFSET ARMS



4410223 OS HD DISC SEALER WITH OFFSET ARMS

SIZE	A	SHEET TITLE:	ASSEMBLY	REV	A
SCALE:	1:8	SHEET 1 OF 1			

4410185, STANDARD SIDE DRESS DISC SEALER WITH 14.5" ARMS

INDEPENDENT STYLE W 14.5 INCH ARM

#	PART NUMBER	Q
1	4410185 INDEPENDENT STYLE W 14.5 INCH ARM	1
2	4410195 UPPER MOUNTING BRACKET ASSEMBLY	1
3	DS 4420287 UPPER MOUNTING BRACKET, LONG ARM FLOPPY, WELDMENT	1
4	DS 4410259 PIVOT ARM, LONG	2
5	4440857 BUSHING, COMPOSITE	2
6	DS 4420288 PIVOT ARM, 14.5 INCH	1
7	150251 FLAT WASHER, 1.25 ID X 1.875 OD	2
8	101689 SPRING PIN, .375x2	2
9	158006 FLANGE BOLT, .5 NC X 1.75, G.5	4
10	158007 FLANGE NUT, .5 NC	8
11	4440788 U-BOLT, 2 X 2.5 X .5 NC, SQUARE HEAD	2
12	4420277 HUB ASSEMBLY, STD	2
13	DS 4420273 HUB BRACKET, STD, WELDMENT	1
14	DS 4420201 SPINDLE HUB, STD, WELDMENT	1
15	151222 GREASE ZERK, .25 SELF TAPPING	1
16	4440704 SEAL	1
17	4440702 BEARING	2
18	4440703 RACE	2
19	150224 FLAT WASHER, .625	1
20	4440737 SLOTTED NUT	1
21	150406 COTTER PIN, 1.25 X 2	1
22	GDS909923 DUST CAP, 1.75	1
23	151835 CARRIAGE BOLT, 3.75 X .75 NC PLTD	8
24	DS 4440785 BLADE, 18 INCH NOTCHED	2
25	158005 FLANGE NUT, .375 NC	8

ALL QUANTITIES ARE PER ROW UNIT

4450048 - STANDARD DISC SEALER REBUILD KIT
-INCLUDES (2) BEARINGS, (2) RACES, AND (1) SEAL

4410185 INDEPENDENT STYLE W 14.5 INCH ARM
INCLUDES ALL ITEMS

PROPRIETARY AND CONFIDENTIAL
 THE INFORMATION CONTAINED IN THIS DRAWING IS THE SOLE PROPERTY OF DALTON A.G. ANY REPRODUCTION IN PART OR AS A WHOLE WITHOUT THE WRITTEN PERMISSION OF DALTON A.G. IS PROHIBITED.

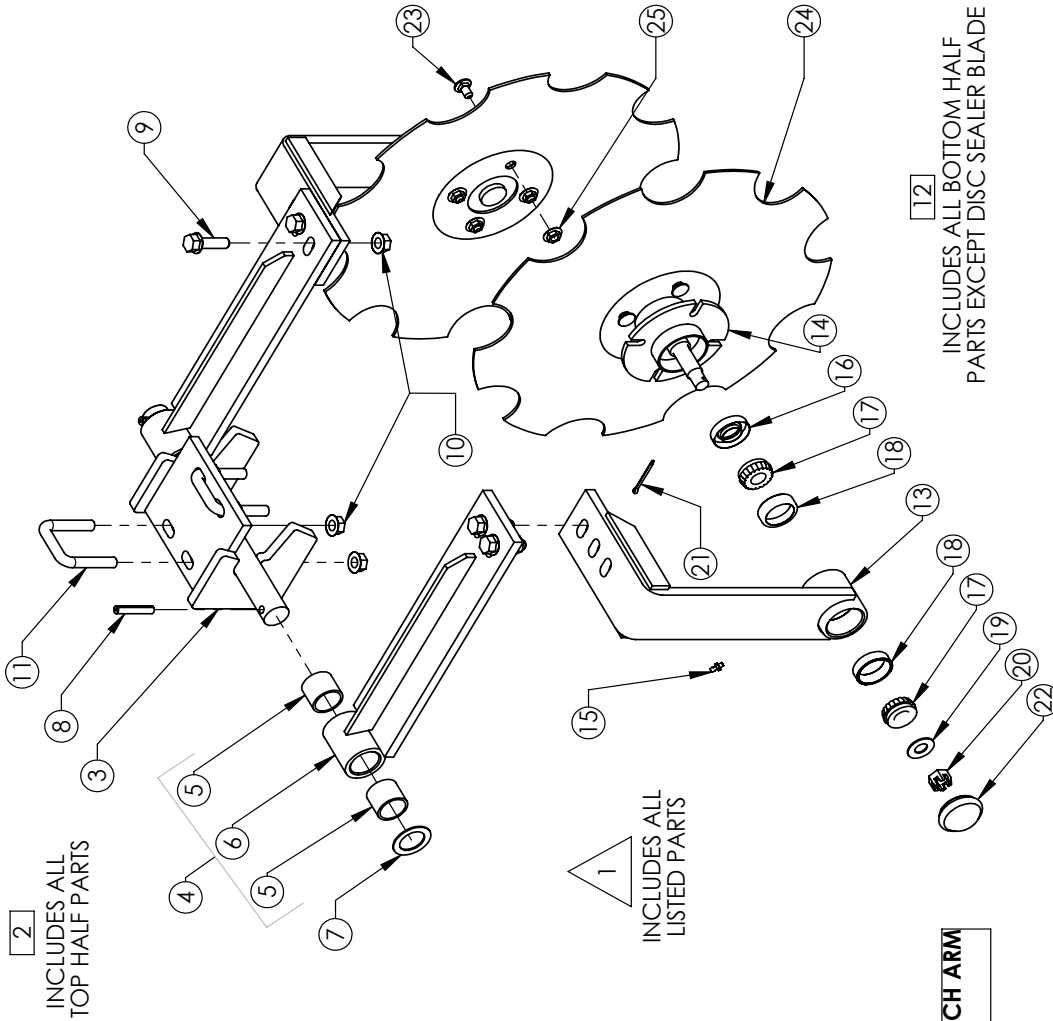

DRAWN BY	RICH SMOTHERS	10/21/2013
CHECKED BY		
PRINT DATE	8/25/2016	
CONFIG.	EXP VIEW	
COMMENTS:	4410185 INDEPENDENT STYLE W 14.5 INCH ARM DWG: INDEPENDENT STYLE W 14.5 INCH ARM	
SIZE	A	REV A
SHEET TITLE:	B.O.M.	REV A
SCALE:	1:8	SHEET 1 OF 1

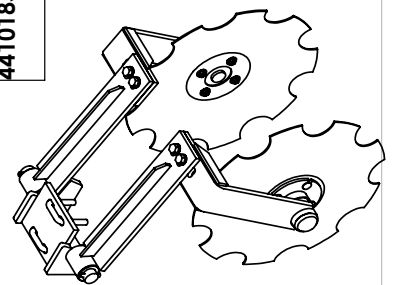

4410926 SIDE DRESS DISC SEALER

4410926 SIDE DRESS DISC SEALER 14.5 INCH ARM HD

#	PART NUMBER	DESCRIPTION	QTY.
1	4435857	SIDE PLATE, LONG ARM, HD	2
2	4435858	5X6 MOUNTING PLATE, LONG ARM, HD	1
3	4435855	SPINDLE, LONG ARM, HD	1
4	4420581	PIVOT ARM, HD, LONG	2
5	4440815	SEAL, HD DISC SEALER, 1.372 X 1.979 X .432	2
6	4440816	BEARING CONE, HD DISC SEALER	4
7	4440817	BEARING CUP, HD DISC SEALER	4
8	158012	WASHER, 3/4", 3/4 SAE FLAT WASHER	2
9	4440814	DUST CAP, 2", HD DISC SEALER	2
10	158003	NUT, SLOTTED, 3/4-16, 3/4-16 SLT HEX NUT	2
11	150409	COTTER PIN	2
12	151222	GREASE FITTING	2
13	4440788	U-BOLT, 2 X 2.5 X .5 NC, SQUARE HEAD	2
14	158007	FLANGE NUT, .5 NC	8
15	4435859	HD CAP RETAINER	2
16	158006	FLANGE BOLT, .5 X 1.75 NC, G5	4
17	151805	BOLT, .375 X 1.25 NC, PLTD	2
18	150005	NUT, .375 NC, PLTD	2
19	150248	LOCK WASHER, .375, SS	2
20	4421749	HUB BRACKET, WELDMENT, HD, UNIT HUB	2
21	158311	NUT, CENTER LOCK, M22-1.5 CL 8.8, ZINC	2
22	4441760	HUB, UNIT BEARING, DISC SEALER	2
23	4431391	HUB CAP	2
24	4440785	BLADE, 18 INCH NOTCHED	2
25	158312	FLANGE BOLT, M12-1.25 X 20, GR 10.9, ZINC	8

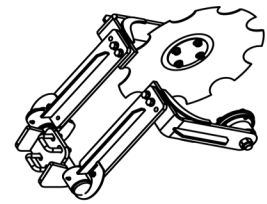
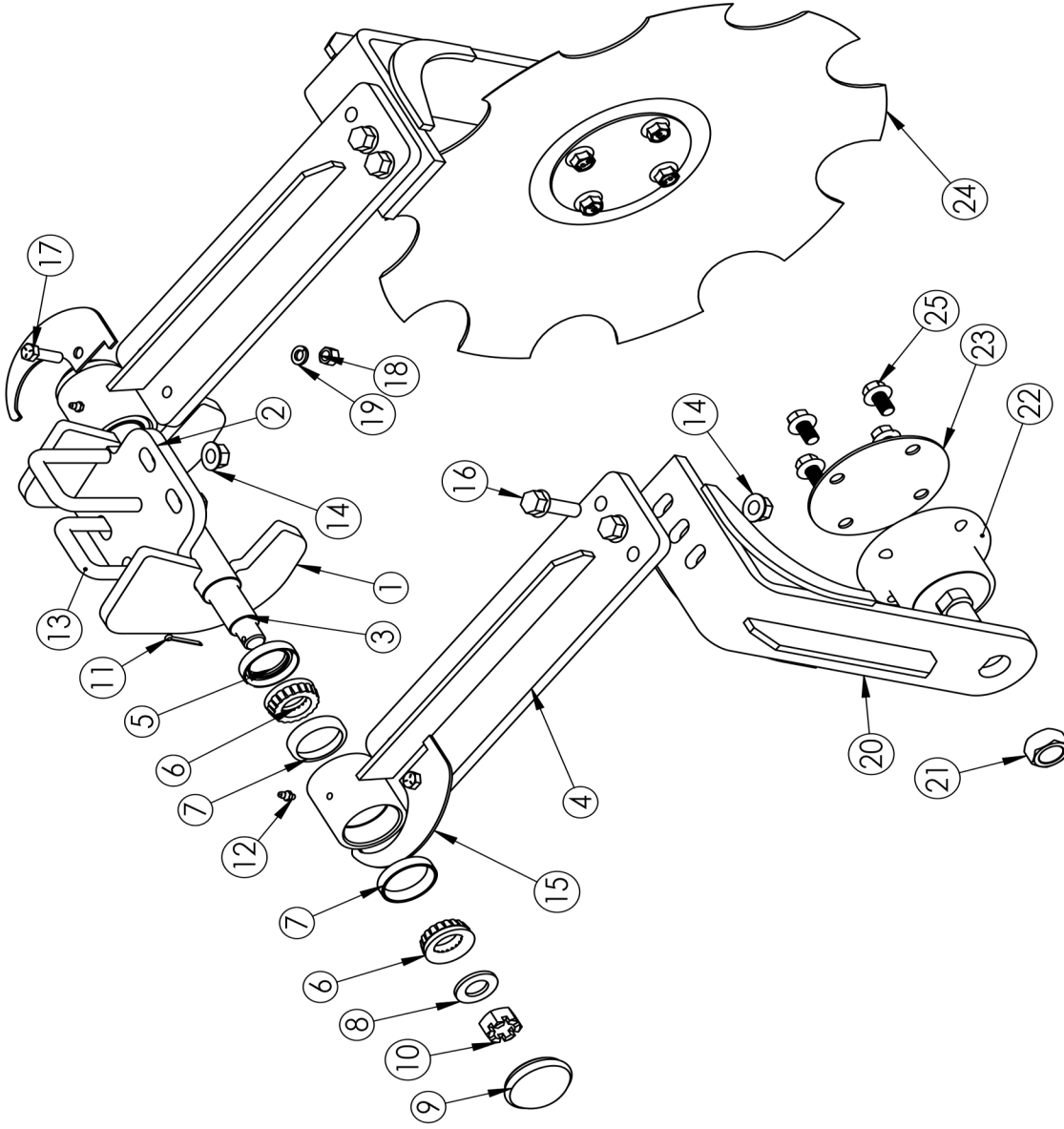

DRAWN BY Tyler Jackson 4/9/2024

CHECKED BY

4/10/2024

PRINT DATE

CONFIG. Default

COMMENTS:



DWG: 4410926

SIDE DRESS DISC SEALER 14.5 IN ARM HD

SIZE SHEET TITLE: A Sheet1 REV 0

SCALE: 1:24 SHEET 1 OF 1

PROPRIETARY AND CONFIDENTIAL
THE INFORMATION CONTAINED IN THIS DRAWING IS THE SOLE PROPERTY OF DALTON AG. ANY REPRODUCTION IN PART OR AS A WHOLE WITHOUT THE WRITTEN PERMISSION OF DALTON AG IS PROHIBITED.

C:\SOLIDWORKS Data\EPDM_Vault\Row Units\Disc Sealer\Ds Assembly\ 3 2 1

4410190, STANDARD SHORT ARM DISC SEALER

INDEPENDENT STYLE, CENTER SEALER W 14 INCH NOTCHED BLADES

#	PART NUMBER	QTY.
1	4410190 INDEPENDENT STYLE, CENTER SEALER w 14 INCH NOTCHED BLADES Δ	1
2	DS 4410194 UPPER MOUNTING BRACKET, 14 INCH BLADE □	1
3	4420283 SHANK MOUNTING BRACKET	1
4	4410258 PIVOT ARM, SHORT, RH	1
5	4410257 PIVOT ARM, SHORT, LH	1
6	4440857 BUSHING, COMPOSITE	2
7	101689 SPRING PIN .375x2	2
8	150251 FLAT WASHER, 1.25 ID x 1.875 OD	2
9	158006 FLANGE BOLT, .5 NC x 1.75, G5	4
10	158007 FLANGE NUT, .5 NC	8
11	4440788 U-BOLT, 2 x 2.5 x .5 NC, SQUARE HEAD	2
12	158005 FLANGE NUT, .375 NC	8
13	DS 4440808 BLADE, 14 INCH NOTCHED	2
14	151835 CARRIAGE BOLT, .375x.75 NC PLTD	8
15	4420284 DISC SEALER HUB ASSEMBLY □	2
16	DS 4420541 DISC SEALER, HUB BRACKET WLD ONLY, 14 INCH	1
17	4440703 RACE	2
18	4440702 BEARING	2
19	4440704 SEAL	1
20	150224 FLAT WASHER, .625	1
21	4440737 SLOTTED NUT,	1
22	150406 COTTER PIN, .125 x 2	1
23	DS 4420201 SPINDLE HUB, STD, WELDMENT	1
24	GDS90923 DUST CAP, 1.75	1
25	151222 GREASE ZERK, .25 SELF TAPPING	1

ALL QUANTITIES ARE PER ROW UNIT

4410190 INDEPENDENT STYLE, CENTER SEALER W 14 INCH NOTCHED BLADES

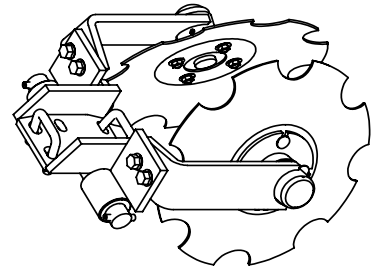

INCLUDES ALL BOTTOM HALF PARTS EXCEPT DISC SEALER BLADE

1 INCLUDES ALL LISTED PARTS

2 INCLUDES ALL TOP HALF PARTS

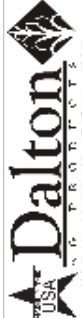
 <p>602 E. VAN BUREN ST., LENOX, IA 50851</p>	DWG: INDEPENDENT STYLE, CENTER SEALER W 14 INCH NOTCHED BLADES SIZE: SHEET TITLE: A B.O.M. REV: A
DRAWN BY: RICH SMOTHERS CHECKED BY: PRINT DATE: 8/24/2016 CONFIG: EXP VIEW	10/23/2013 8/24/2016 EXP VIEW
COMMENTS: 4410190 INDEPENDENT STYLE, CENTER SEALER W 14 INCH NOTCHED BLADES	
PROPRIETARY AND CONFIDENTIAL THE INFORMATION CONTAINED IN THIS DRAWING IS THE SOLE PROPERTY OF DALTON AG. ANY REPRODUCTION IN PART OR AS A WHOLE WITHOUT THE WRITTEN PERMISSION OF DALTON AG IS PROHIBITED.	
SCALE: 1:5	SHEET 1 OF 1

4410925 EDGE SPRING LOADED DISC SEALER

440925 EDGE SPRING LOADED DISC SELAER

#	PART NUMBER	DESCRIPTION	QTY.
1	4410709	EDGE SPRING LOADED UPPER MOUNT	1
2	4410901	HD HUB ASSEMBLY, PARABOLIC UNIT BEARING, W- DISK	2
3	158006	FLANGE BOLT, .5 X 1.75 NC, G5	4
4	158007	FLANGE NUT, .5 NC	4
5	158073	NUT, .5625 NC, CENTERLOCK, PLTD	2
6	158277	BOLT, .5625 X 3 NC GR 8	2

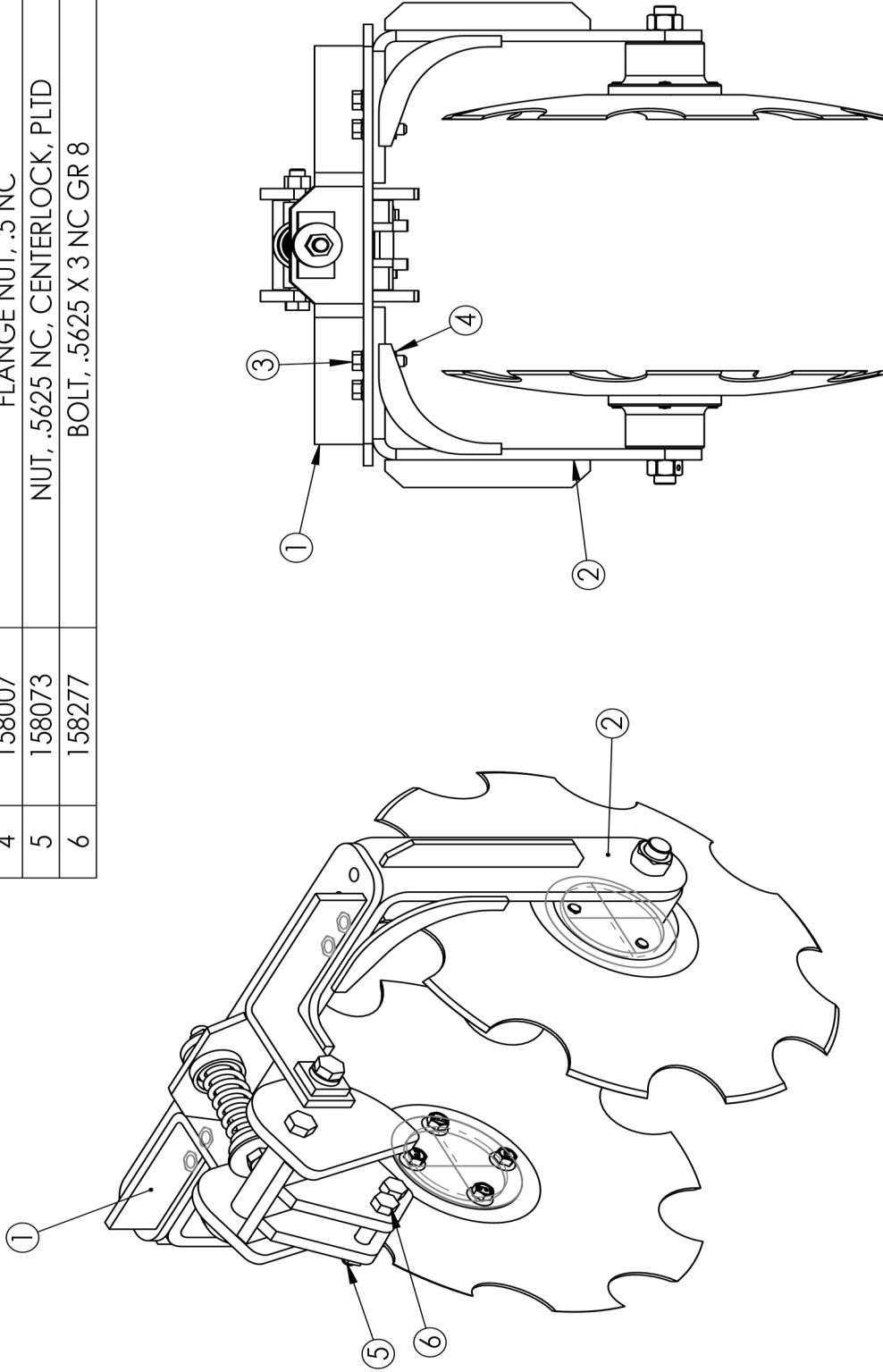

DRAWN BY Tyler Jackson 4/10/2024
 CHECKED BY
 PRINT DATE 4/10/2024
 CONFIG. Default
 COMMENTS:

UNLESS OTHERWISE SPECIFIED
 TOLERANCES TO BE:
 ANGLES: ± 1.0°
 FRACTIONS <6": ±1/32, >6": 1/16
 X.X: ± 0.06
 X.XX: ± 0.03
 X.XXX: ± 0.005

DWG: 4410925
 EDGE SPRING LOADED DISC SEALER

SIZE SHEET TITLE: A Sheet1 REV 0

SCALE: 1:12 SHEET 1 OF 1

PROPRIETARY AND CONFIDENTIAL
 THE INFORMATION CONTAINED IN THIS DRAWING IS THE SOLE PROPERTY OF DALTON AG. ANY REPRODUCTION IN PART OR AS A WHOLE WITHOUT THE WRITTEN PERMISSION OF DALTON AG IS PROHIBITED.

C:\SOLIDWORKS Data\EPDM_Vault\Row Units\Disc Sealer\Ds Assembly\	3	2	1
5	4	2	1

4410934 HSC GEN 2 DISC SEALER

ITEM NO.	PART NUMBER	DESCRIPTION	QTY.
1	4410794	HSC GEN 2 DISC SEALER w/ARMS	1
2	4410900	HD HUB ASSEMBLY PARABOLIC UNIT BEARING	2
3	4440785	BLADE, 18 INCH NOTCHED	2
4	4431391	HUB CAP	2
5	158312	FLANGE BOLT, M12-1.25 X 20, GR 10.9, ZINC	8
6	158006	FLANGE BOLT, .5 x 1.75 NC, G5	4
7	158007	FLANGE NUT, .5 NC	4

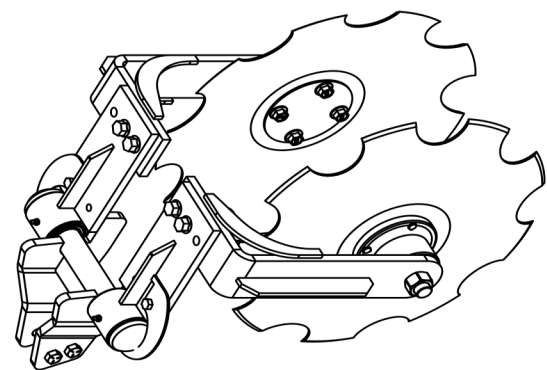
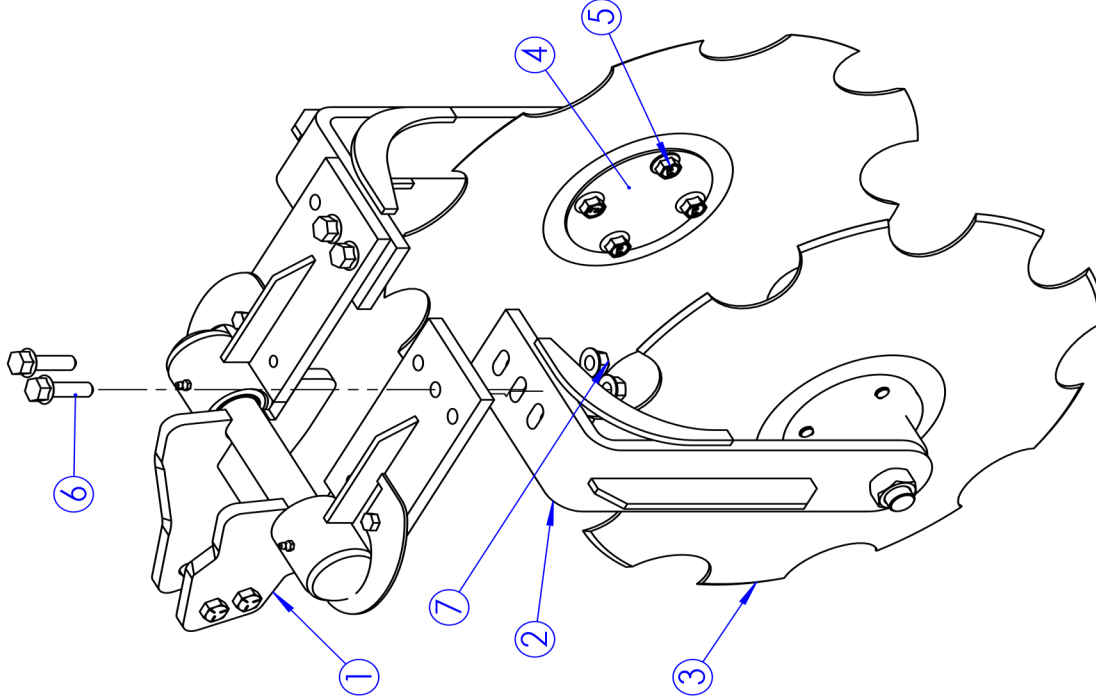

DRAWN BY: Tyler Jackson
 CHECKED BY:
 PRINT DATE: 6/13/2024
 CONFIG: Default
 COMMENTS:

UNLESS OTHERWISE SPECIFIED
 TOLERANCES TO BE:
 ANGLES: ± 1.0°
 FRACTIONS <6": ±1/32, >6": 1/16
 X.X: ± 0.06
 X.XX: ± 0.03
 X.XXX: ± 0.005

DWG: 4410934
 HSC GEN 2 DISC SEALER WITH UNIT BEARING
 SIZE: A
 SHEET TITLE: Sheet
 REV: 0
 SCALE: 1:20
 SHEET 1 OF 1

PROPRIETARY AND CONFIDENTIAL
 THE INFORMATION CONTAINED IN THIS DRAWING IS THE SOLE PROPERTY OF DALTON AG. ANY REPRODUCTION IN PART OR AS A WHOLE WITHOUT THE WRITTEN PERMISSION OF DALTON AG IS PROHIBITED.

4410934-OS HSC GEN 2 DISC SEALER - OFF SET ARM

ITEM NO.	PART NUMBER	DESCRIPTION	QTY.
1	4410794	HSC GEN 2 DISC SEALER w/ARMS	1
2	4410900	HD HUB ASSEMBLY PARABOLIC UNIT BEARING	2
3	4440785	BLADE, 18 INCH NOTCHED	2
4	4431391	HUB CAP	2
5	158312	FLANGE BOLT, M12-1.25 X 20, GR 10.9, ZINC	8
6	158006	FLANGE BOLT, .5 x 1.75 NC, G5	4
7	158007	FLANGE NUT, .5 NC	4

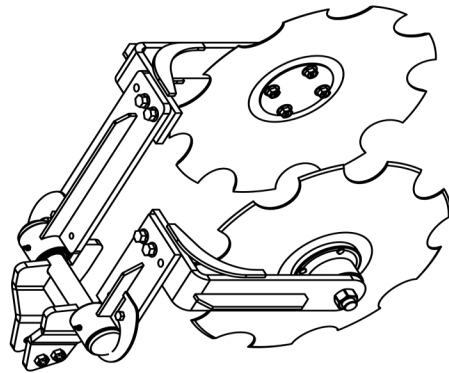
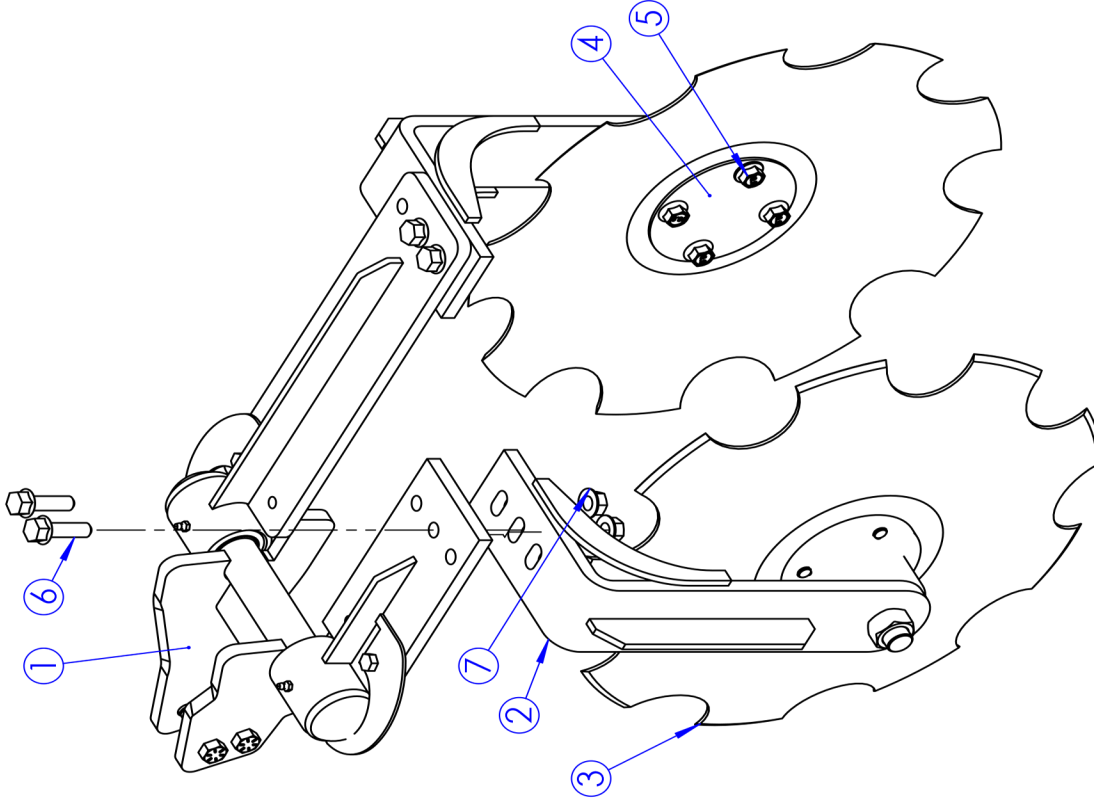

DRAWN BY: Tyler Jackson
 CHECKED BY:
 PRINT DATE: 6/13/2024
 CONFIG: Default
 COMMENTS:

UNLESS OTHERWISE SPECIFIED
 TOLERANCES TO BE:
 ANGLES: ± 1.0°
 FRACTIONS <6": ± 1/32, >6": 1/16
 X.X: ± 0.06
 X.XX: ± 0.03
 X.XXX: ± 0.005

DWG: 4410934-OS
 HSC GEN 2 DISC SEALER WITH OFFSET ARM AND
 SIZE SHEET TITLE: UNIT BEARING
 Sheet# 0
 REV 0

PROPRIETARY AND CONFIDENTIAL
 THE INFORMATION CONTAINED IN THIS DRAWING IS THE SOLE PROPERTY OF DALTON AG. ANY REPRODUCTION IN PART OR AS A WHOLE WITHOUT THE WRITTEN PERMISSION OF DALTON AG IS PROHIBITED.

4410912 EDGE HD DISC SEALER

ITEM NO.	PART NUMBER	DESCRIPTION	QTY.
1	4410738	EDGE HD UPPER MOUNT	1
2	4410901	HD HUB ASSEMBLY, PARABOLIC UNIT BEARING, W- DISK	2
3	158277	BOLT, .5625 X 3 NC GR 8	2
4	158073	NUT, .5625 NC, CENTERLOCK, PLTD	2

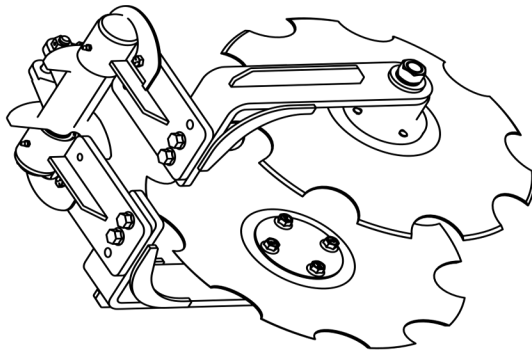
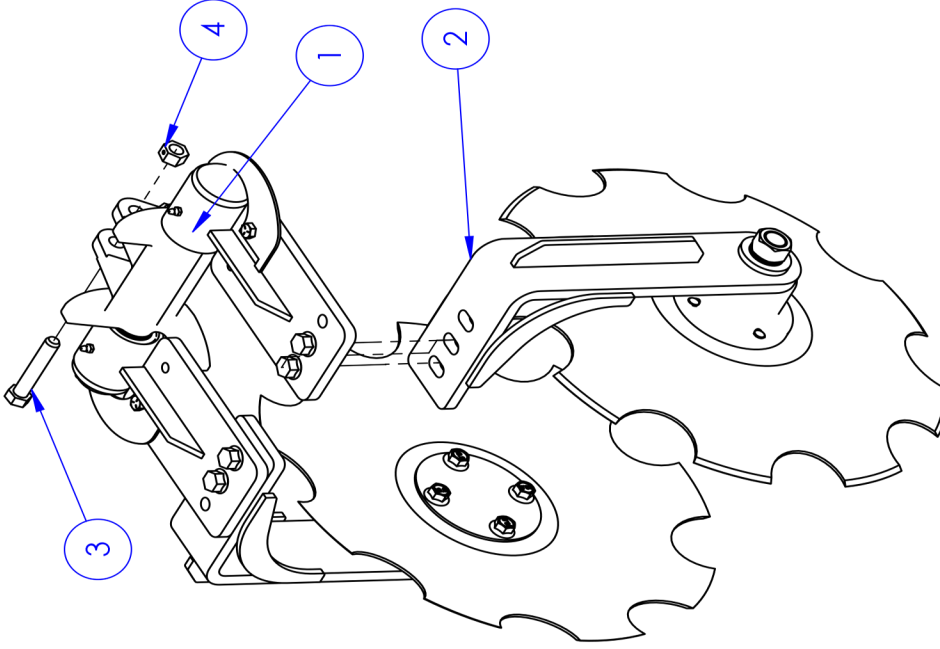

REVISIONS			
REV.	DESCRIPTION	DATE	APPD



DRAWN BY: Tyler Jackson
 CHECKED BY:
 PRINT DATE: 7/12/2024
 CONFIG: BUILT
 COMMENTS:

UNLESS OTHERWISE SPECIFIED
 TOLERANCES TO BE:
 ANGLES: ± 1.0°
 FRACTIONS <6": ±1/32, >6": 1/16
 X.X: ± 0.06
 X.XX: ± 0.03
 X.XXX: ± 0.005

DWG: 4410912
 EDGE HD DISC SEALER

SIZE: A
 SHEET TITLE: Sheet1
 REV: 0

PROPRIETARY AND CONFIDENTIAL
 THE INFORMATION CONTAINED IN THIS DRAWING IS THE SOLE PROPERTY OF DALTON AG. ANY REPRODUCTION IN PART OR AS A WHOLE WITHOUT THE WRITTEN PERMISSION OF DALTON AG IS PROHIBITED.

44109120-OS EDGE HD DISC SEALER - OFF SET

ITEM NO.	PART NUMBER	DESCRIPTION	QTY.
1	4410843	EDGE HD UPPER MOUNT OFFSET	1
2	4410901	HD HUB ASSEMBLY, PARABOLIC UNIT BEARING, W- DISK	2
3	158277	BOLT, .5625 X 3 NC GR 8	2
4	158073	NUT, .5625 NC, CENTERLOCK, PLTD	2

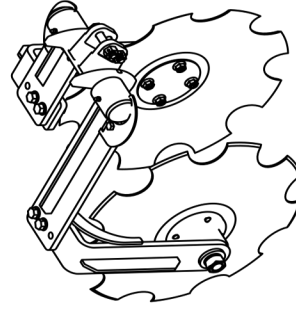
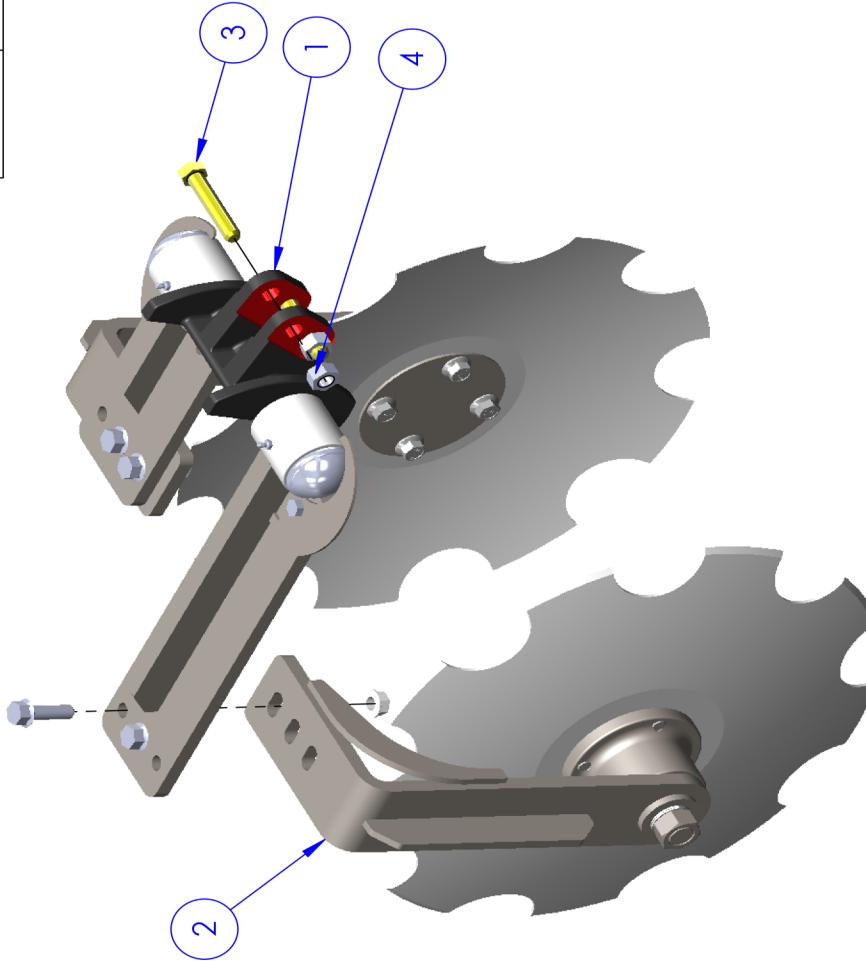

UNLESS OTHERWISE SPECIFIED TOLERANCES TO BE: ANGLES: ± 1.0° FRACTIONS <6": ± 1/32, >6": 1/16 X.X: ± 0.06 X.XX: ± 0.03 X.XXX: ± 0.005	DRAWN BY: Tyler Jackson	7/23/2024
	CHECKED BY:	7/23/2024
PRINT DATE:	BUILT:	COMMENTS:
PROPRIETARY AND CONFIDENTIAL THE INFORMATION CONTAINED IN THIS DRAWING IS THE SOLE PROPERTY OF DALTON AG. ANY REPRODUCTION IN PART OR AS A WHOLE WITHOUT THE WRITTEN PERMISSION OF DALTON AG IS PROHIBITED.		
C:\SOLIDWORKS Data\EPDM_Vault\Row Units\Disc Sealer\Ds ASSEMBLY	3	2
5	4	1



DWG: 44109120-OS

EDGE HD DISC SEALER UNIT BEARING HUBS WITH
 SIZE SHEET TITLE: OFFSET ARMS
 Sheet REV 0

SCALE: 1:16 SHEET 1 OF 1

S1264SL, SPRING LOADED SHANK CLAMP, 4 X 6

#	PART NUMBER	QTY.
1	S1264SL COMPLETE SPRING LOADED SHANK CLAMP	1
2	4410218 S1264SL W/O TOP BRACKET AND BOLTS	1
3	SLSC 4420281 SHANK PIVOT	1
4	SLSC 4420280 SPRING GUIDE CAP	1
5	SLSC 4420282 SPRING BOLT WELDMENT	1
6	SLSC 4431072 TOP BRACKET	1
7	SLSC 641480 SPRING	1
8	4440789 U-BOLT, 1.5 x 3 x .5 NC, ROUND HEAD	2
9	150008 NUT, .5 NC, PLTD	4
10	150013 NUT, .75 NC	1
11	150218 LOCK WASHER, .5, PLTD	4
12	150220 FLAT WASHER, .5 PLTD	4
13	152422 BOLT, .625 NC x 8, G5	4
14	150226 LOCK WASHER, .75, PLTD	1
15	158000 NUT, .75 NF	1
16	158001 JAM NUT, .75 NF	1
17	150011 NUT, .625 NC, LOCKING, PLTD	4
18	4441060 BOLT, .75 NC x 3, GR 8	1

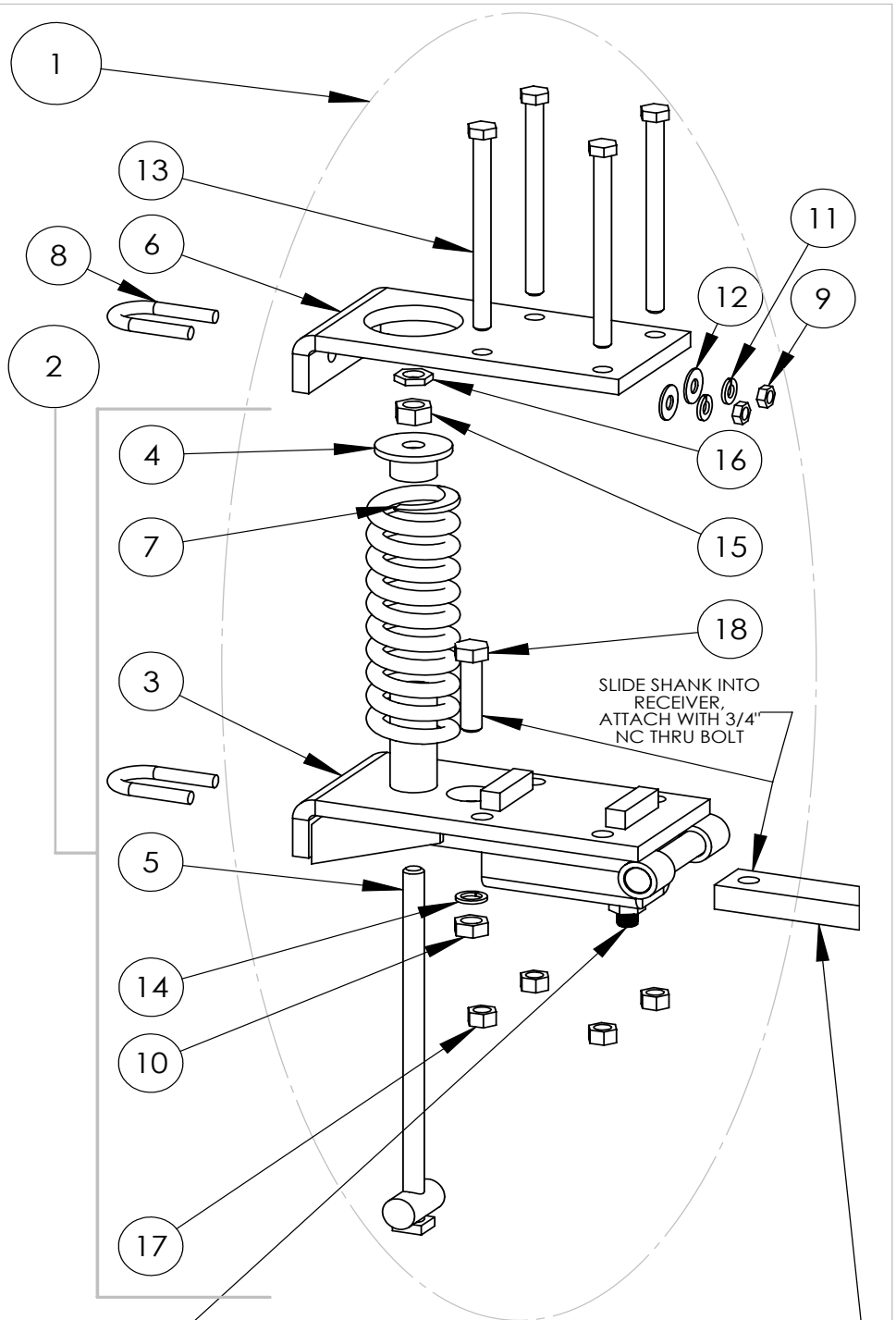

4440975 .75 NC X 1.5 SET SCREW

SHANK NOT INCLUDED

DRAWN BY	RICH SMOTHERS	4/9/2009
CHECKED BY		
PRINT DATE	9/8/2016	
CONFIG.	EXPLODED	
COMMENTS:		



DWG: SLSC S1264SL-SPRING LOADED SHANK CLAMP

PROPRIETARY AND CONFIDENTIAL
THE INFORMATION CONTAINED IN THIS DRAWING IS THE SOLE PROPERTY OF DALTON AG. ANY REPRODUCTION IN PART OR AS A WHOLE WITHOUT THE WRITTEN PERMISSION OF DALTON AG IS PROHIBITED.

S1264SL-SPRING LOADED SHANK CLAMP

SIZE	SHEET TITLE:	REV
A	COMPLETE UNIT EXPLODED	A
SCALE: 1:6	SHEET 1 OF 1	

S1266SL, SPRING LOADED SHANK CLAMP, 6 X 6

#	PART NUMBER	QTY.
1	S1266SL SPRING LOADED SHANK CLAMP	1
2	4410246 S1266SL W/O TOP BRACKET AND BOLTS	1
3	SLSC 4420280 SPRING GUIDE CAP	1
4	SLSC 4420282 SPRING BOLT WELDMENT	1
5	SLSC 4420466 SHANK PIVOT, 6x6	1
6	SLSC 4435829 TOP BRACKET 6X6	1
7	SLSC 641480 SPRING	1
8	4440789 U-BOLT, 1.5 x 3 x .5 NC, ROUND HEAD	2
9	150008 NUT, .5 NC, PLTD	4
10	150013 NUT, .75 NC	1
11	150218 LOCK WASHER, .5, PLTD	4
12	150220 FLAT WASHER, .5 PLTD	4
13	152422 BOLT, .625 NC x 8, G5	4
14	150226 LOCK WASHER, .75, PLTD	1
15	4441060 BOLT, .75 NC x 3, GR 8	1
16	158000 NUT, .75 NF	1
17	158001 JAM NUT, .75 NF	1
18	150011 NUT, .625 NC, LOCKING, PLTD	4

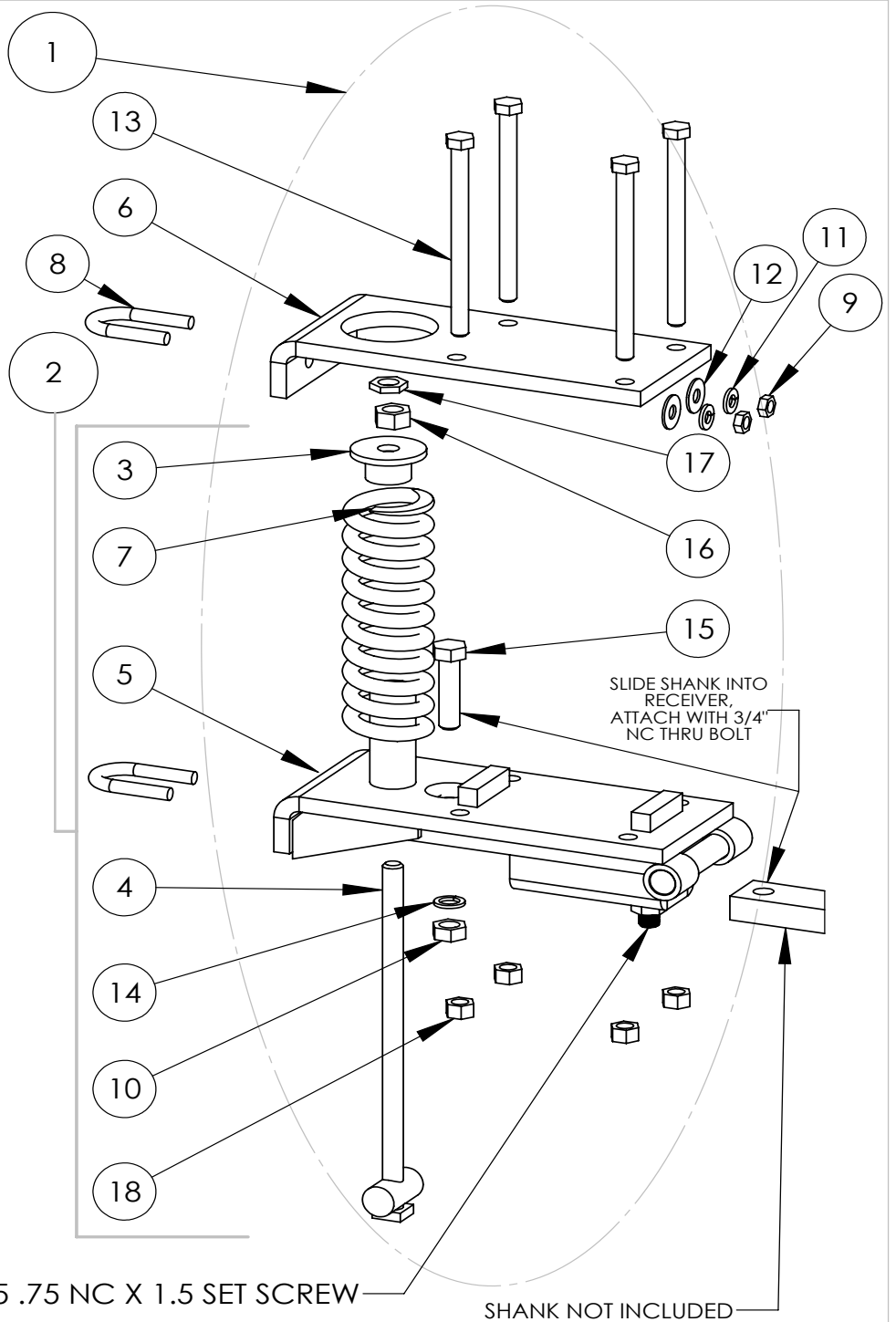

4440975 .75 NC X 1.5 SET SCREW

SHANK NOT INCLUDED

DRAWN BY	RICH SMOTHERS	4/9/2009
CHECKED BY		
PRINT DATE		9/8/2016
CONFIG.	EXPLODED	



DWG: SLSC S1266SL-SPRING LOADED SHANK CLAMP, 6x6

SIZE	SHEET TITLE:	REV
A	COMPLETE UNIT EXPLODED	A
SCALE: 1:6	SHEET 1 OF 1	

PROPRIETARY AND CONFIDENTIAL
 THE INFORMATION CONTAINED IN THIS DRAWING IS THE SOLE PROPERTY OF DALTON AG. ANY REPRODUCTION IN PART OR AS A WHOLE WITHOUT THE WRITTEN PERMISSION OF DALTON AG IS PROHIBITED.

S1266SL-SPRING LOADED SHANK CLAMP, 6x6

4410920 SPRING LOAD 6x6 EDGE BENT

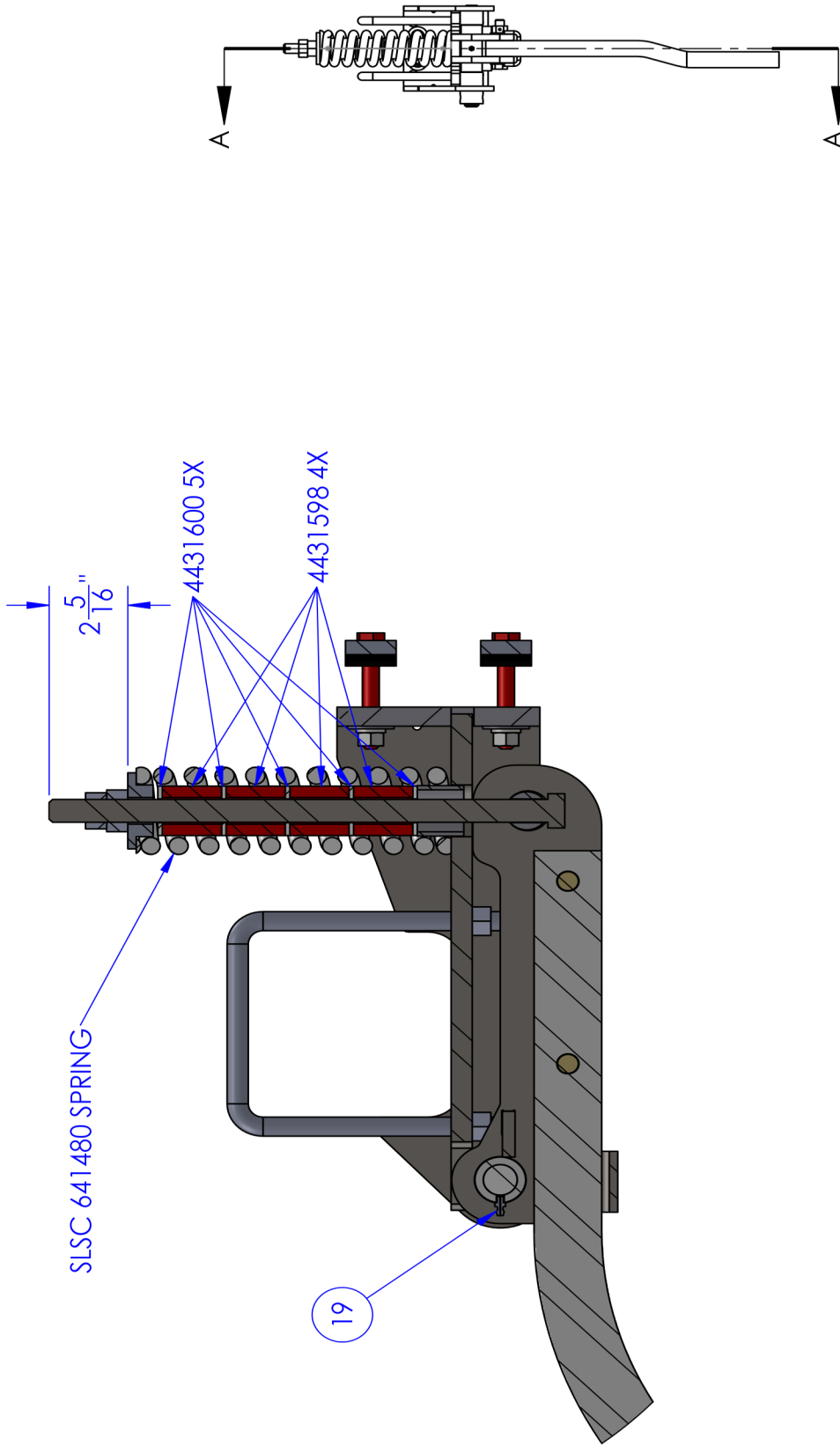

DWG: 4410920
 SPRING LOAD 6X6, EDGE BENT W COULTER
 SIZE SHEET TITLE: MOUNTS, V3 REV 0
 Sheet# 0

DRAWN BY Donald Sundberg 4/2/2024
 CHECKED BY
 PRINT DATE 7/2/2024
 CONFIG. EXPLODED
 COMMENTS:

SECTION A-A
 SCALE 1 : 5
 UNLESS OTHERWISE SPECIFIED
 TOLERANCES TO BE:
 ANGLES : ± 1.0°
 FRACTIONS <6" : ±1/32, >6" : 1/16
 X.X : ± 0.06
 X.XX : ± 0.03
 X.XXX : ± 0.005

PROPRIETARY AND CONFIDENTIAL
 THE INFORMATION CONTAINED IN THIS DRAWING IS THE SOLE PROPERTY OF DALTON AG. ANY REPRODUCTION IN PART OR AS A WHOLE WITHOUT THE WRITTEN PERMISSION OF DALTON AG IS PROHIBITED.

FOR PARTS, CALL 1.800.342.7498	5	4	3	2	1
SCALE: 1:12	SHEET 2 OF 2				

4410920 SPRING LOAD 6X6 EDGE BENT

ITEM NO.	PART NUMBER	DESCRIPTION	QTY.
1	4421874	PIVOT MOUNT EDGE BENT V3	1
2	641480	SPRING	1
3	150011	NUT, .625 NC, LOCKING, PLTD	4
4	4440453	BOLT .625 X 3.5 NC GRD 8 PLTD	2
5	188082	NUT, .625 NC, CENTERLOCK, PLTD	2
6	SLSC 4440813	SPRING BOLT .75 NF X 14.75	1
7	4435889	SPRING BOLT ROCKER STOP, EDGE BENT	1
8	158001	JAM NUT, .75 NF	1
9	4420280	SPRING CAP, MACHINED	1
10	158000	NUT, .75 NF	1
11	4441156	EDGE BENT SHANK	1
12	4441105	COULTER SHAFT CLAMP	2
13	152236	BOLT .5 X 3.5 NC, G5	4
14	150220	FLAT WASHER, .5 PLTD	4
15	150218	LOCK WASHER, .5 PLTD	4
16	150008	NUT, .5 NC, GR 5, PLTD	4
17	150223	WASHER, .625", .625 SAE FLAT WASHER	4
18	4421855	SHANK ROCKER, 6X6, V2	1
19	151222	GREASE FITTING	1
20	4432914	PIN, 1 X 7.25, HEADLESS	1
21	4441725	ROLL PIN, 7/16" X 1.5", ZINC PLATED	1
22	4441083	U-BOLT, .625X6.125X8 SQUARE	2
23	4431600	SPACER WASHER	5
24	4431598	URETHANE SPRING	4

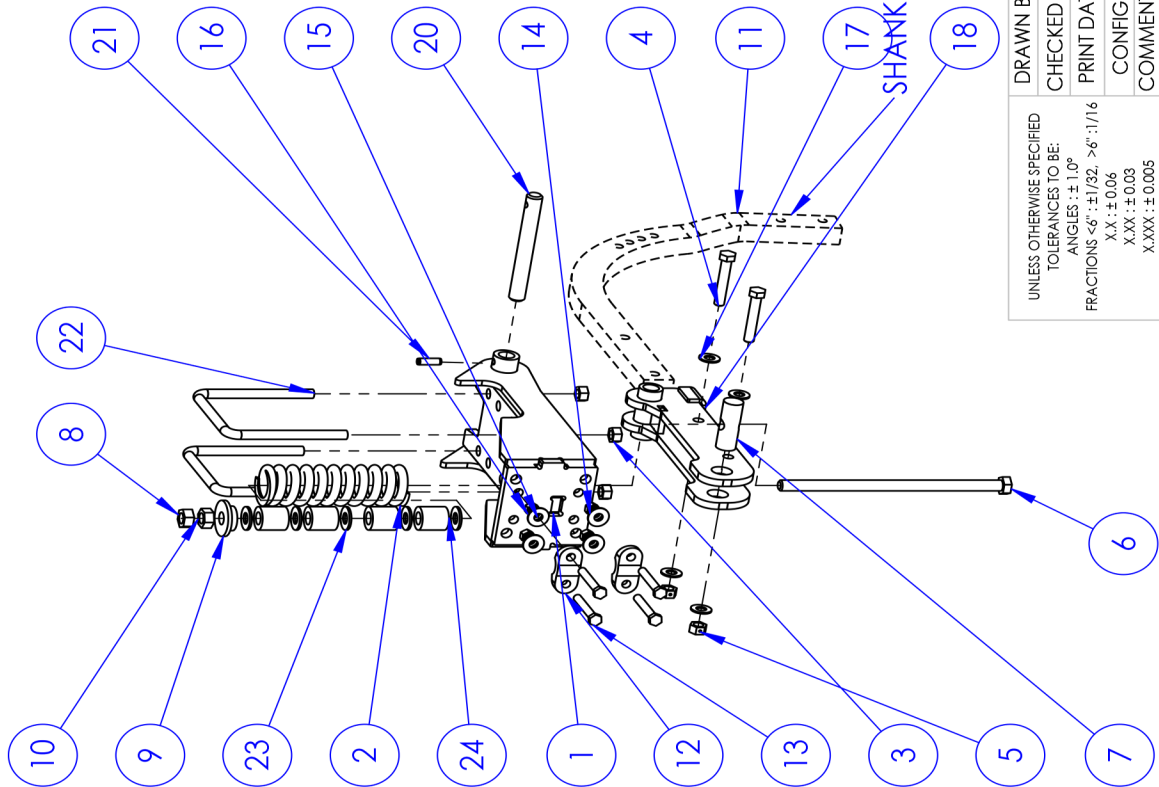

SHANK NOT PART OF PACKAGE

UNLESS OTHERWISE SPECIFIED
TOLERANCES TO BE:
ANGLES: ± 1.0°
FRACTIONS <6": ±1/32, >6": 1/16
X.X: ± 0.06
X.XX: ± 0.03
X.XXX: ± 0.005

PROPRIETARY AND CONFIDENTIAL
THE INFORMATION CONTAINED IN THIS DRAWING IS THE SOLE PROPERTY OF DALTON AG. ANY REPRODUCTION IN PART OR AS A WHOLE WITHOUT THE WRITTEN PERMISSION OF DALTON AG IS PROHIBITED.

DRAWN BY Donald Sundberg
CHECKED BY
PRINT DATE 7/2/2024
CONFIG. EXPLODED
COMMENTS:

DWG: 4410920
SPRING LOAD 6X6, EDGE BENT W COULTER
SIZE SHEET TITLE: MOUNTS, V3
Sheet
REV 0



Your Dalton Ag dealer is interested in your new fertilizer application equipment and has the desire to help you get the most value from it. Through the help of this manual, you will find you can do some of the regular maintenance yourself. For parts and service, contact the Dalton Ag Dealership from which you purchased your fertilizer application equipment or your local Dalton Ag dealer.

When replacement parts are required, consult the applicable illustration and parts list to obtain the correct part name and number. When requesting a replacement part, always include the following information:

1. Complete Part Number
2. Description
3. Quantity Required
4. Machine and Model Number
5. Machine Serial Number - located on the topside of the frame near hitch
6. Provide complete name and address for where and how parts are to be shipped.

NOTE: Right and left hand parts and sides of the units are determined by standing at the rear and facing in the direction of forward travel.

EQUIPMENT MODEL: _____

EQUIPMENT SERIAL NO.: _____

DATE OF PURCHASE: _____

NAME OF DEALER: _____

DEALER'S PHONE NUMBER: _____

Thank you for your business!



LIMITED WARRANTY STATEMENT

DALTON AG, INC. warrants to the original purchaser only that all products manufactured under the Dalton Ag and Mobility Brands will be free from defects in material and workmanship under normal use and service.

DALTON AG’s obligation under this warranty is limited to repairing or replacing, as it may elect, free of charge and without charge for installation, at the place of business of a dealer or distributor authorized to handle the equipment covered by this warranty or at a DALTON AG facility, any parts that prove, in DALTON AG's judgment, to be defective in material or workmanship within one (1) year after delivery to the original purchaser. DALTON AG shall not be liable for personal injuries or any special or consequential damages of any kind, either direct or indirect. This warranty is subject to acts of God, fire and existing conditions of supply and demand, production, ability or inability to deliver, or for any other valid reason beyond the reasonable control of DALTON AG. No distributor, dealer, agent or DALTON AG employee (other than DALTON's President in writing) is authorized to extend or make any other or further express or implied warranty or incur any additional obligation on DALTON AG’s behalf in connection with the sale of this product.

Customer Responsibility

Product Registration - It is a condition of this warranty that the original purchaser fill out the warranty card furnished by DALTON AG and return it to DALTON AG to be recorded in DALTON AG’s owner file. Registration may also be done on line at www.DaltonAg.com/warrantyregistration. If the original purchaser's card or electronic registration is not on file at DALTON AG’s office, the warranty period will extend only from date equipment was picked up or shipped from the DALTON AG plant.

Maintenance - It is the customer’s responsibility to maintain their equipment in accordance with the instructions provided in the Operator’s Manual. DALTON AG recommends that you keep records and receipts as the customer may be required to verify the maintenance instructions have been followed.

Operation – It is the customer’s responsibility to operate the equipment only for the purpose for which it was designed and in accordance with all safety and operational recommendations contained in the Operator's Manual. If a defect in materials or workmanship occurs, it is the customer’s responsibility to cease operating the equipment until authorized repairs are made.

Damage incurred from continued operation after a defect is discovered may not be covered by this warranty.

What this Warranty Covers

This warranty covers failures caused by defects in materials or workmanship only.

This Warranty does not cover failures caused by:

- Improper operation
- Natural calamities
- Unauthorized modifications
- Unauthorized repairs
- Use of Non DALTON AG parts
- Neglected maintenance
- Usage contrary to the intended purpose of the product

This Warranty does not cover replacement of Wear or Maintenance Items including, but not limited to:

- Lubricants
- Filters
- Hoses
- Tires
- Disks
- Chains
- Idlers
- Blades
- Belts
- Bearings

This Warranty does not cover:

- Pickup and delivery of the equipment
- Service Calls or Travel Time to and from sites
- Rental of replacement equipment during repair period
- Products that have been declared a total loss and subsequently salvaged
- Overtime labor charges

Parts Warranty

DALTON AG warrants its replacement parts against defects in materials or workmanship for a period of 90 days or the remainder of the product warranty, whichever is longer under the terms set out above. Remedy for defective replacement parts for units that are beyond the original product warranty, will be limited to replacement of the failed part.

DaltonAg.com

602 E. Van Buren Lenox, Iowa 50851
100% Employee Owned

PHONE: 800.342.7498
FAX: 641.333.4429



www.daltonag.com

602 E. VAN BUREN / LENOX, IOWA 50851 / 800-342-7498