



OPERATING AND PARTS MANUAL

Mobility 100 Spreader

2026



TABLE OF CONTENTS

TO YOU THE OWNER.....	1
LIMITED WARRANTY STATEMENT.....	2
NEW MACHINE CHECKOUT.....	3
OPERATION AND SAFETY.....	4
LUBRICATION SCHEDULE.....	5
LUBRICATION DETAIL.....	6
MACHINE ADJUSTMENT.....	7
SPECIFICATIONS.....	8
SPREAD ADJUSTMENT & APPLICATION RATES.....	9
SPREAD PATTERN DETAILS.....	10
STANDARD SPREAD SETUP.....	11
DISTRIBUTOR BLADE TUNING.....	12
40' SPREAD.....	13
50' SPREAD.....	14
FRAME & DRIVELINE.....	15
540 PTO.....	16
1000 PTO.....	17
6 BOLT, HEAVY HUB ASSEMBLY.....	18
GROUND DRIVE ASSEMBLY.....	19-20
FRONT TANK ASSEMBLY.....	21
REAR AREA ASSEMBLY.....	22-23
DISTRIBUTOR GEAR BOX.....	24
HYDRAULIC SPINNER GEAR BOX.....	25
TRACTOR HYDRAULIC DRIVEN SPINNERS.....	26
VARIABLE CONTROL, ELECTRICAL PLAN.....	27
CONVEYOR CLUTCH OPTION.....	28-29
TRACTOR HYDRAULIC DRIVEN SPINNERS.....	30
BOLT TORQUE CHART.....	31
VARIABLE RATE CONTROL, HYDRAULIC PLAN.....	32
BANDER OPTION.....	33
PARTS ORDERING PROCEDURE.....	34

TO YOU, THE OWNER

Your Dalton Ag Equipment is the most modern, up-to-date, versatile, machine available for fertilizer application. The machine is the result of many years of experience, research, development and testing of equipment for fertilizer application. It is soundly engineered and carefully built to rigid specifications. It is of rugged and simple construction, with a minimum of moving parts.

However, to obtain maximum performance from your Dalton Ag Equipment, it is necessary to follow the instructions and safety suggestions in this manual. Each section has been carefully prepared for the purpose of providing needed and valuable information to the owner and operator. Each operator of this unit should be familiar with the contents of this manual. Keep it in a safe and convenient location. THERE ARE MANY SAFETY SUGGESTIONS (CAUTION AREAS) PRINTED THROUGHOUT THIS MANUAL. CAREFULLY READ THEM ALL BEFORE OPERATING THIS UNIT.

DESIGN IMPROVEMENTS

Dalton Ag Products follows a policy of continuous products improvement. We therefore reserve the right to make design improvements, and changes in specifications and prices, without incurring obligations to make revisions or additions to equipment previously sold.

**REGISTER
WARRANTY
ONE OF
FOUR WAYS**

- Register on-line at:
www.daltonag.com
- Fax your completed warranty registration form to:
641-333-4429
- Email your completed warranty registration form to:
office@daltonag.com
- Mail your completed warranty registration form to:
Dalton Ag, Inc.
P.O. Box 70
Lenox, IA 50851



LIMITED WARRANTY STATEMENT

DALTON AG, INC. warrants to the original purchaser only that all products manufactured under the Dalton Ag and Mobility Brands will be free from defects in material and workmanship under normal use and service.

DALTON AG’s obligation under this warranty is limited to repairing or replacing, as it may elect, free of charge and without charge for installation, at the place of business of a dealer or distributor authorized to handle the equipment covered by this warranty or at a DALTON AG facility, any parts that prove, in DALTON AG's judgment, to be defective in material or workmanship within two (2) years after delivery to the original purchaser. DALTON AG shall not be liable for personal injuries or any special or consequential damages of any kind, either direct or indirect. This warranty is subject to acts of God, fire and existing conditions of supply and demand, production, ability or inability to deliver, or for any other valid reason beyond the reasonable control of DALTON AG. No distributor, dealer, agent or DALTON AG employee (other than DALTON's President in writing) is authorized to extend or make any other or further express or implied warranty or incur any additional obligation on DALTON AG’s behalf in connection with the sale of this product.

Customer Responsibility

Product Registration - It is a condition of this warranty that the original purchaser fill out the warranty card furnished by DALTON AG and return it to DALTON AG to be recorded in DALTON AG’s owner file. Registration may also be done on line at www.DaltonAg.com/warrantyregistration. If the original purchaser's card or electronic registration is not on file at DALTON AG’s office, the warranty period will extend only from date equipment was picked up or shipped from the DALTON AG plant.

Maintenance - It is the customer’s responsibility to maintain their equipment in accordance with the instructions provided in the Operator’s Manual. DALTON AG recommends that you keep records and receipts as the customer may be required to verify the maintenance instructions have been followed.

Operation – It is the customer’s responsibility to operate the equipment only for the purpose for which it was designed and in accordance with all safety and operational recommendations contained in the Operator's Manual. If a defect in materials or workmanship occurs, it is the customer’s responsibility to cease operating the equipment until authorized repairs are made.

Damage incurred from continued operation after a defect is discovered may not be covered by this warranty.

What this Warranty Covers

This warranty covers failures caused by defects in materials or workmanship only.

This Warranty does not cover failures caused by:

- Improper operation
- Natural calamities
- Unauthorized modifications
- Unauthorized repairs
- Use of Non DALTON AG parts
- Neglected maintenance
- Usage contrary to the intended purpose of the product

This Warranty does not cover replacement of Wear or Maintenance Items including, but not limited to:

- Lubricants
- Filters
- Hoses
- Tires
- Disks
- Chains
- Idlers
- Blades
- Belts
- Bearings

This Warranty does not cover:

- Pickup and delivery of the equipment
- Service Calls or Travel Time to and from sites
- Rental of replacement equipment during repair period
- Products that have been declared a total loss and subsequently salvaged
- Overtime labor charges

Parts Warranty

DALTON AG warrants its replacement parts against defects in materials or workmanship for a period of 90 days or the remainder of the product warranty, whichever is longer under the terms set out above. Remedy for defective replacement parts for units that are beyond the original product warranty, will be limited to replacement of the failed part.

NEW MACHINE CHECKOUT

Before attempting to use or operate the spreader it is important to be thoroughly familiarized with the contents of this manual. Then the machine should be checked using the following check list:

1. Ground drive tire inflated to 22 PSI. Tires inflated to manufacturing specifications.
2. All bearings lubricated and tightly mounted with collars securely locked.
(See lubrication schedule page 5.)
3. Conveyor chains, drive chain & ground drive chain adjusted to correct tension. Conveyor chain should be flush or just below the bottom of the trough in the area approximately 2' behind the front roller.
4. Sprockets tightened & in proper alignment.
5. Inspect entire machine for loose bolts, especially in the spinner assembly and drive line area.
6. Distributor fan blades set properly. (See spread adjustment and application rates)
7. Setting of metering gate. With the pointer on the number 1 of the spread rate chart decal, the lower edge of the metering gate should be 1 ¼" above the trough floor.
8. Tighten wheel bolts daily – 95 foot pounds single axle spreaders.
9. Check drive line for ease of operation by turning shaft by hand. If the foregoing inspection reveals that additional lubrication or adjustment is required, refer to the proper section of this manual for detailed instructions.
10. Ground drive wheel and universal joint shear pins in place and tight.
11. Check both spinner gear boxes for oil; fill to level of pipe plug with SAE No. 90 non-detergent oil.

OPERATION

SPREADER SAFETY

Before starting in motion please read the following words of caution.

- A. It is recommended that initial spreading be done in as low a range as possible to permit easy break-in.
- B. Always shut off or disconnect power to spreader before attempting to repair or adjust the spreader.
- C. Do not transport machine with ground drive wheel engaged.
- D. NEVER back-up spreader with ground drive wheel engaged.
- E. Make sure that the towing vehicle brakes are operating properly and are capable of stopping the towing vehicle.
- F. If a pick-up is used as the towing vehicle, it is wise to add ballast for additional safety and traction. We recommend that all towing vehicles be ballast loaded to their recommended G.V.W.
- G. Hitches should be of heavy construction and should be welded or bolted directly to the towing vehicle frame. Hitches should be checked routinely for loose bolts, cracked welds, etc.
- H. Never tow a spreader with a drawbar pin less than 1" in diameter. Pins should also have a locking device.
- I. Do not tow spreader at speeds in excess of 20 mph loaded or 40 mph empty.
- J. Remember, that the stopping and braking distances vary with load and vehicle speed. It is well to familiarize yourself with the characteristics of your machine under different load and speed conditions.
- K. Be sure to attach safety break-away chain and the safety chain to towing vehicle to assure control of spreader in the case of pin or hitch failure.
- L. The unit is designed for hitching to vehicles with drawbar heights between 12 and 18 inches above the ground level. It will operate with all standard tractor hitches and PTO's. WARNING: Hydraulically mounted drawbars must be securely and mechanically locked because a fully loaded spreader applies a load in the order of 2000 lbs. to the hitch.
- M. WARNING: Remember this unit is designed for agricultural use only and is primarily an off-the-road vehicle and should be towed at tractor speeds ONLY, not to exceed 20 mph loaded or 40 mph empty. Inspect hubs routinely to see if they are heating, which indicates either a need for lubrication or improper adjustment of brakes or bearings, also check stud nuts for tightness.
- N. WARNING: The maximum capacity of this unit is 6 tons (600) or 200 cubic feet, based on a material density of 60 pounds per cubic foot. DO NOT EXCEED THIS LIMIT!

OPERATING INSTRUCTIONS

Please read the following completely before spreading.

- 1) Attach spreader to towing vehicle, make sure hitch and hitch pin are sound.
- 2) Attach PTO shaft to proper rpm PTO.
- 3) Spinner discs, adjustable chute and conveyor floor should be clean for accurate metering.
- 4) Set metering gate to desired spread rate according to decal on the back end sheet of tank. Always keep the machine in the lowest possible range.
- 5) Before starting to spread, rotate the ground drive wheel several revolutions by hand to make sure the conveyor chain is operating freely. If chain is frozen or moves with too much resistance, correct problem before using spreader.
- 6) If the ground drive wheel operates properly, check with chain and sprocket arrangement for desired range setting and chain tension.
- 7) When spreading is complete, disengage ground drive assembly from the tire and install transport lockup.

LUBRICATION SCHEDULE

DAILY LUBRICATION SCHEDULE	DRIVELINE	ALL MODELS	(4) BEARINGS	
			(2) U-JOINTS	
	GROUND DRIVE	GROUND DRIVE		(1) BEARING
				(4) U-JOINTS
				(2) TELESCOPING TUBES
	CONVEYOR DRIVE	ALL MODELS		(6) BEARINGS
	GROUND DRIVE	ALL MODELS		(2) SHAFT HOUSINGS
				(2) U-JOINTS
			TELESCOPING TUBE	
			(2) SQUIRTS OF SAE 90 OIL INTO JACK CRANK	
			OIL CAP	

Pay particular attention to the daily cleaning and greasing of the telescoping tube assembly.

WEEKLY LUBRICATION SCHEDULE	CHAINS	OIL	LUBRICATE PIN JOINTS WITH SAE 80-90
	PTO SHAFT	GREASE	(2) U-JOINTS AND SLIP TUBE
	SPINNER GEARBOX	GREASE	UNIVERSAL GREASE ON EACH FITTING UNDER SPINNER HUB

MONTHLY LUBRICATION SCHEDULE	DRIVE SHAFT SPLINES	COAT WITH GREASE OR ANTI-SEIZE COMPOUND
	SPINNER GEAR BOX	CHECK TO SEE THAT OIL LEVEL IS UP TO OIL LEVEL PLUG. USE SAE 90 OIL

ANNUAL LUBRICATION SCHEDULE	WHEEL BEARINGS	REPACK
	GEAR BOXES	DRAIN, FLUSH, AND REFILL WITH SAE 90 OIL

MAINTENANCE SCHEDULE

WEEKLY	WASH SPREADER
	CHECK GROUND DRIVE TIRE INFLATION (22 PSI)
	CORRECT BELT TENSION
	ADJUST TENSION OF CONVEYOUR AND DRIVE CHAINS (SEE MACHINE CHECKOUT)

SEMI-ANNUALLY	TIGHTEN LOOSE BOLTS
	REPLACE WORN OR FAILED PARTS
	TOUCH-UP PAINT

LUBRICATION DETAIL

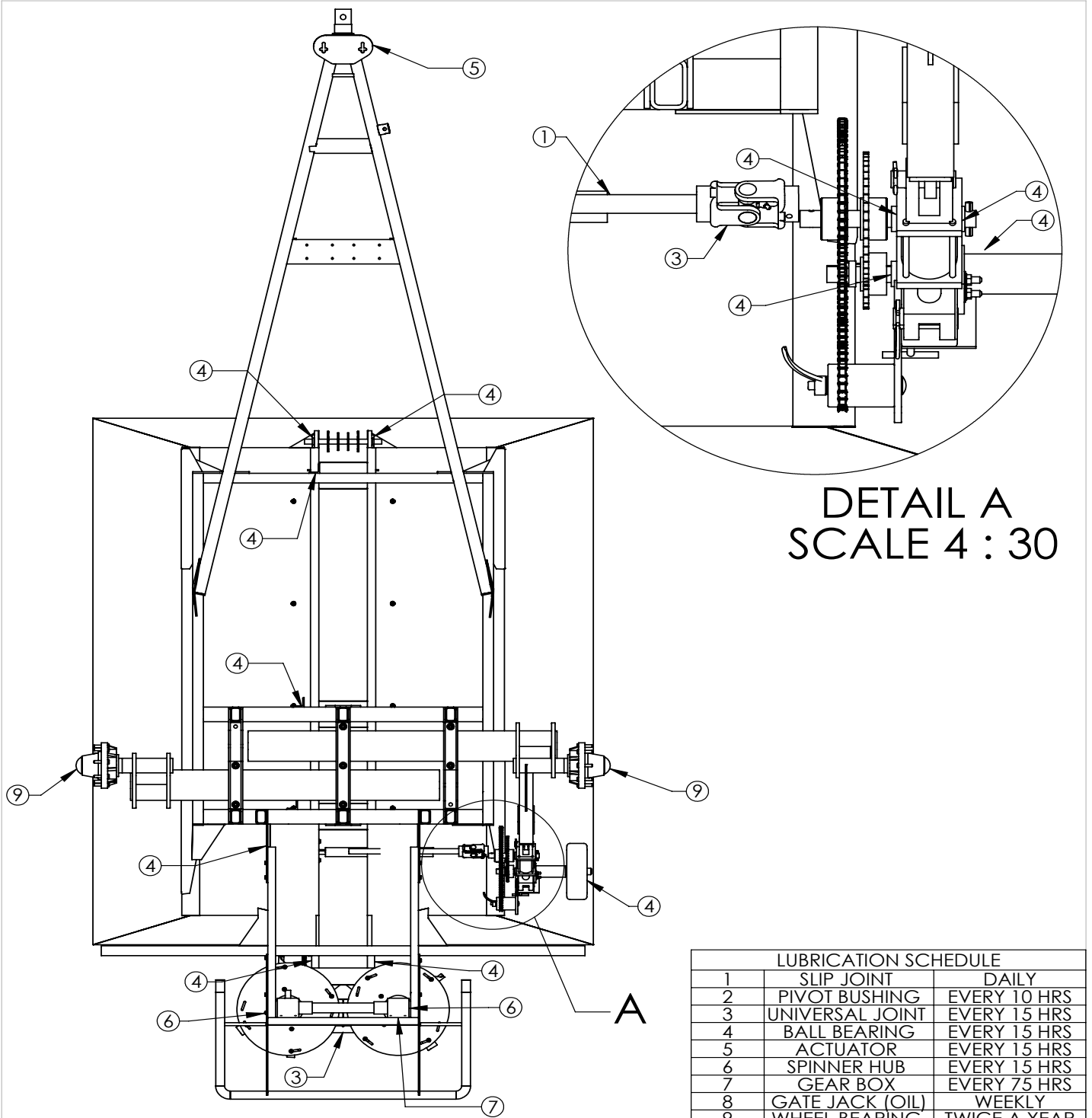

DETAIL A
SCALE 4 : 30

LUBRICATION SCHEDULE		
1	SLIP JOINT	DAILY
2	PIVOT BUSHING	EVERY 10 HRS
3	UNIVERSAL JOINT	EVERY 15 HRS
4	BALL BEARING	EVERY 15 HRS
5	ACTUATOR	EVERY 15 HRS
6	SPINNER HUB	EVERY 15 HRS
7	GEAR BOX	EVERY 75 HRS
8	GATE JACK (OIL)	WEEKLY
9	WHEEL BEARING	TWICE A YEAR

DRAWN BY	RICH SMOTHERS	2/9/2010
CHECKED BY		
PRINT DATE	7/28/2014	
CONFIG.	Default	
COMMENTS:		

PROPRIETARY AND CONFIDENTIAL
THE INFORMATION CONTAINED IN THIS DRAWING IS THE SOLE PROPERTY OF DALTON AG. ANY REPRODUCTION IN PART OR AS A WHOLE WITHOUT THE WRITTEN PERMISSION OF DALTON AG IS PROHIBITED.



DWG: LUBRICATION SCHEDULE		
SIZE A	SHEET TITLE: Sheet1	REV A
SCALE: 1:26	SHEET 1 OF 1	

FOR PARTS, CALL 1.800.342.7498

MACHINE ADJUSTMENT

WHEEL BEARING ADJUSTMENT

After repacking or when inspecting wheel bearings, the following adjustment procedure should be followed. Place flat washer and spindle nut on spindle. Turn hub as you tighten nut. When a pronounced drag is felt in the bearings, back off nut one complete slot. If necessary continue to back off the nut until the next slot aligns with the cotter pin hole and install cotter pin and dust cap.

CONVEYOR CHAIN ADJUSTMENT

Loosen chain take-up locking nuts on outside of front end of trough. Adjust take-up bolts evenly until chain clears main frame members and axle tube by $\frac{3}{4}$ " $\frac{1}{2}$ ". Inspect shaft bearing mounting bolts and shaft locking collars for tightness of set screws (6 places). Reset take-up locking nuts.

STORAGE

Before storing the spreader for more than a few days, the machine should be emptied completely and thoroughly washed both inside and out. This precaution will minimize the severity of fertilizer acid corrosion, extend the useful life of the machine, and prevent damage to drive line and conveyor chain from fertilizer compaction and caking. We further recommend that the machine be thoroughly greased after washing.

Before operating the machine after extended periods of storage, re-lubricate the entire spreader in accordance with the lubrication section of this manual. Also check the entire spreader, following the New Machine Checkout Procedure to be found in a foregoing section of the manual.

Remember that oil and grease are your least expensive corrosion inhibitors.

ADDITIONAL INSTRUCTIONS:

The ground drive is equipped with the following sprocket combinations: *Low Range* - Drive chain on 12 & 72 Tooth Sprockets. *High Range* - Drive chain on 24 & 48 Tooth Sprockets.

CAUTION

Do not operate your spreader with less than one and a half (1 1/2) inch of metering gate opening as material will compact against metering gate and cause failure of the conveyor chain.

CAUTION

Do not disconnect implement from tractor with material remaining in box.

100 SPREADER SPECIFICATIONS	
FEATURES	
Capacity (Weight)	1 Ton
Hopper Capacity (Volume)	33 cu. ft.
Hopper Length	72"
Hopper Width	45 5/8"
Overall Length	137"
Overall Height	66"
Overall Width	68"
Empty Weight	1,320 lbs.
Wheel Track	55 1/2"
Spread Pattern	40'
Hopper Construction	409 Stainless Steel
Spinners	Dual Gearbox Driven
Jack	5,000 lbs.
Hitch	Clevis
Axle	Single
Tires	11 L x 15 / 6 Bolt
Standard Powder Coat Paint Colors	White
Warranty	24 Months
Options	
Spinner Drive System	Standard: 540 PTO Optional: Tractor Hydraulic Optional: Engine Drive
Conveyor Drive System	2-SPD Ground Drive Optional: Hydraulic
Hydraulic On/Off for Ground-Drive Conveyor	Optional
Light Kit	Optional
Variable Rate Ready	Optional
SRT Roll Tarp	Optional
Stainless Steel Bander	Optional
Hopper Extension	Optional: to 1.5 Ton (50 cu. Ft.)

CAUTION

1. Keep all shields in place.
2. Stop engine before leaving operator's position to adjust, lubricate, clean, or unclog machines.
3. Wait for all movement to stop before servicing the machine.
4. Keep hands, feet and clothing away from power driven parts.
5. Keep off equipment unless seat or platform for operation or observation is provided.
6. Make certain everyone is clear of machine before starting.

PART No. 140959

SPREAD ADJUSTMENT AND APPLICATION RATES

For accurate and precise spreading rates, it is necessary that you know the weight in pounds per cubic foot of the material to be spread. If this is not known, the weight can be quickly and accurately determined by the following method:

1. Weigh an empty one gallon container.
2. Fill level full with the material to be used.
3. Weigh container and material, and then subtract the weight of the container to obtain the weight of the material.
4. Multiply the weight of the material by 7.5 to obtain the weight of the material in pounds per cubic foot.

Example: Typical Material-Potash

1) Weight of empty one gallon container	1.00 lbs.
2) Weight of filled container	10.35 lbs.
3) Weight of container (net)	9.35 lbs.
4) 9.35×7.5	70.125 lbs. /cu ft.

You would therefore use the column on the Spread Chart headed 70 to determine the proper gate opening for the desired application rate.

Your Mobility Spreader with its heavy-duty distributor discs and blades will apply most materials in a 50 foot wide swath.

SPREAD PATTERN DETAILS

An operational characteristic of this type of machine is the possibility of overloading the distributors at high rates of application. Such an overload results in an alteration of the spread pattern to a narrower swath with heavier application at the center. This can be avoided by reducing speed when using high application rates. MOBILITY DISTRIBUTORS ARE DESIGNED FOR A MAXIMUM APPLICATION RATE OF 1500 POUNDS PER MINUTE OF AVERAGE 60 POUND PER CUBIC FOOT MATERIAL. Caution: Be extra careful to check your spread pattern when using high application rates. Adjust your driving pattern to the actual delivered spread swath, the adjustment of the machine, and the material being used. Recommended ground or travel speed for most application rates (up to 700 pounds per acre) is 8 mph. When application rates are in excess of 700 pounds per acre, the ground speed should be proportionately reduced, (for example, at 1400 pounds per acre, maximum ground speed should be 4 mph.) We recommend that for very high application rates, to insure uniformity of application, that two lighter application passes be made preferably placing your second pass over the lap lines of the first pass. This also is recommended practice when spreading under very windy conditions or with a material that segregates easily. If your effective spread pattern is more than 50 feet wide the Metering Gate setting should be increased proportionately, according to the percentage of your spread width in excess of 50 feet. The gate setting should likewise be decreased if your effective spread pattern is less than 50 feet. EXAMPLE: 60 foot effective spread width—increase gate setting from Spread Chart by 20%; 40 foot effective spread pattern width—decrease your gate setting from Spread Chart setting by 20%. Your spread pattern can be checked accurately and visually on a freshly worked, level area of ground. Such an area is also ideally suited to adjusting and fine tuning your machine. The following diagram graphically illustrates a typical spread pattern.

Note on the illustration below that the lap point occurs at the point where the application rate is one-half of the spread chart rate. The profile of the spread pattern tapers at both edges and has a wide uniform area in the center. By careful attention to the lap point during application, a very uniform and even spread rate can be attained. The Mobility Spreaders have been designed to provide this good and uniform tapered profile to make spread width less critical. However, excessive or insufficient overlap of passes will result in a poor application pattern in the lap area of the total spread pattern. If you can attain this spread pattern and pay careful attention to the lap points, the dotted line on the illustration will represent your actual overall spread pattern.

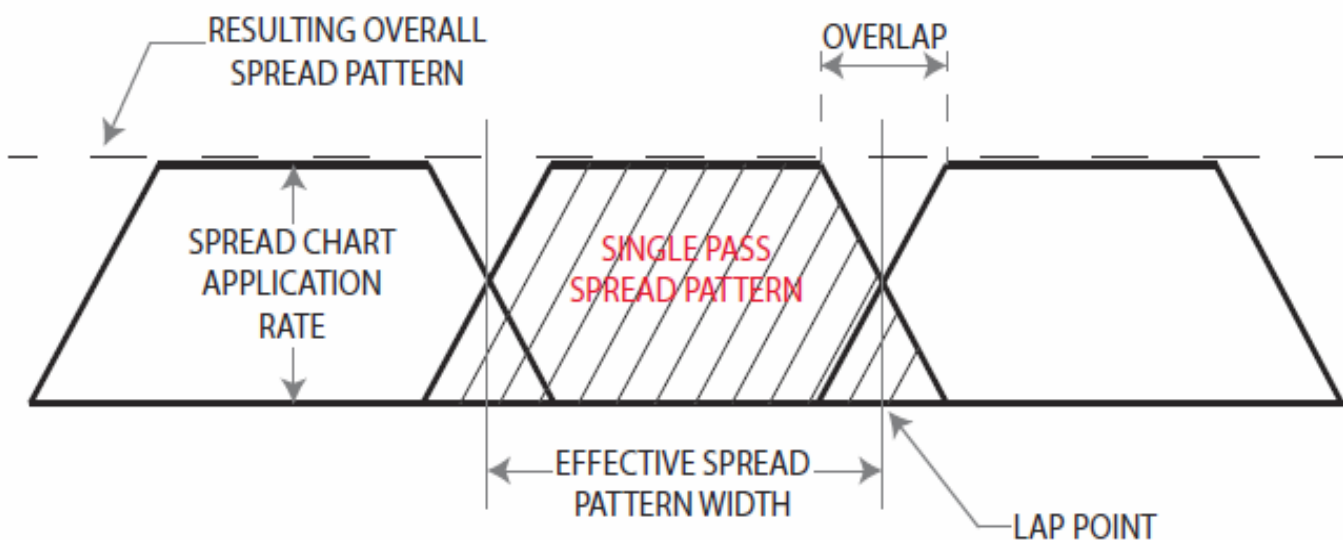

STANDARD SPREAD SETUP

STANDARD SPREAD, BLADE SETUP

#	PART NUMBER	QTY.
1	1003727 DISTRIBUTOR DISC	2
2	MS 1001662 EXTRA LONG DISTRIBUTOR BLADE, 8, RIGHT	1
3	MS 1001705 EXTRA LONG DISTRIBUTOR BLADE, 8, LEFT	1
4	MS 1001718 7 INCH DISTRIBUTOR BLADE, RIGHT	1
5	MS 1001719 7 INCH DISTRIBUTOR BLADE, LEFT	1
6	MS 1001924 4.375 DISTRIBUTOR BLADE, RIGHT	1
7	MS 1001925 4.375 DISTRIBUTOR BLADE, LEFT	1
8	MS 1001926 DISTRIBUTOR BLADE, 5.5, RIGHT	1
9	MS 1001927 DISTRIBUTOR BLADE, 5.5, LEFT	1
10	120393 WASHER, .3125	16

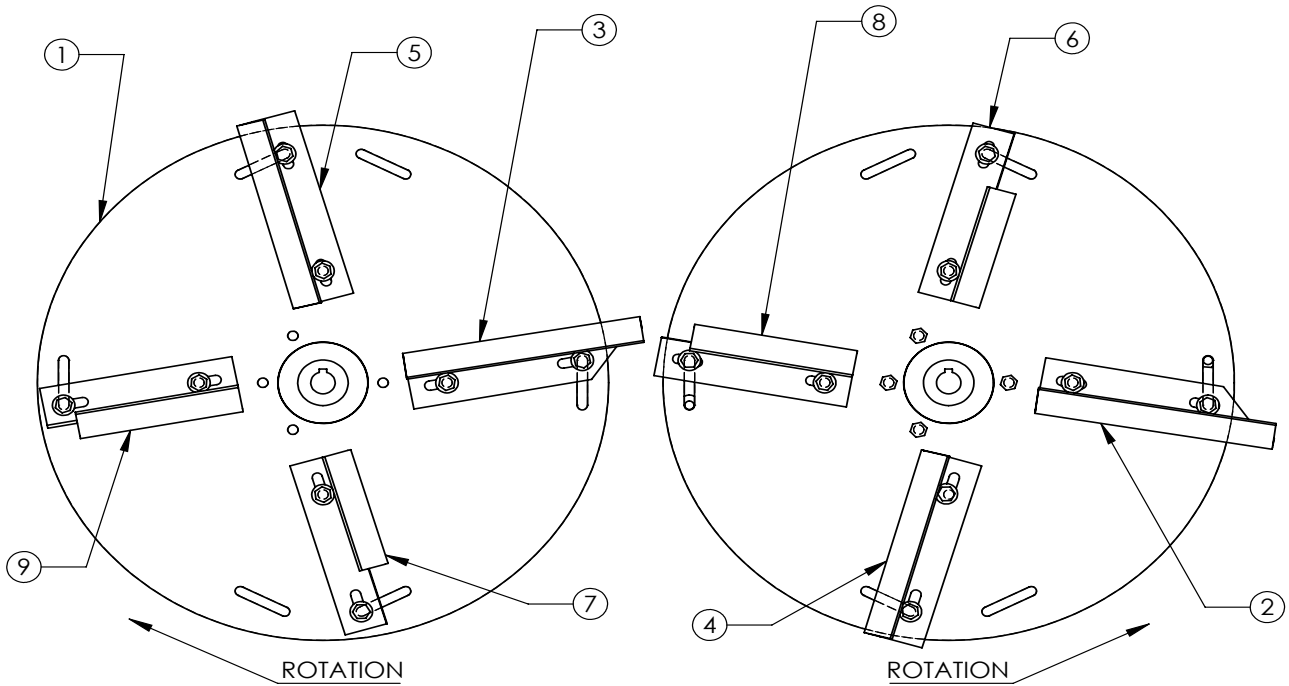

VIEWED FROM BACK OF SPREADER

DRAWN BY	RICH SMOTHERS	9/16/2013
CHECKED BY		
PRINT DATE	11/17/2015	
CONFIG.	STANDARD SPREAD PATTERN, BLADE SETUP	



PROPRIETARY AND CONFIDENTIAL
THE INFORMATION CONTAINED IN THIS DRAWING IS THE SOLE PROPERTY OF DALTON AG. ANY REPRODUCTION IN PART OR AS A WHOLE WITHOUT THE WRITTEN PERMISSION OF DALTON AG IS PROHIBITED.

COMMENTS:

DWG: STANDARD SPREAD, BLADE SETUP

SIZE	SHEET TITLE:	REV
A	Sheet1	A

FOR PARTS, CALL 1.800.342.7498

SCALE: 1:6 SHEET 1 OF 1

DISTRIBUTOR BLADE TUNING

FINE TUNING OF DISTRIBUTOR AND BLADE SETTINGS

All Mobility Spreaders are given an average standard factory setting of distributor blades. Such a setting, of course, cannot be perfect for all field conditions and materials. The following information will be helpful in adjusting the distributor blades on your machine to give optimum performance for your specific conditions.

Your spread pattern will be affected by 1) the material used, 2) the distributor blade setting, and 3) the rotation speed of the distributors. The distributors are designed to be operated at 750 RPM (540 tractor P.T.O. RPM). A plus or minus 10% change in distributor RPM will increase or decrease spread pattern width accordingly. An increase in PTO RPM will tend to deposit less material at the center of the spread pattern, while a decrease will deposit more material at the center. The physical characteristics of the materials being spread, which are important to the spread pattern, include bulk density, particle size, particle shape, physical strength and rugosity or surface roughness. For best performance it is recommended that you fine tune your machine to the material being used. The spreading profile and spread swath width can be changed drastically by alteration of the setting of the distributor blades. The drawing on the next page shows how blades may be extended from or retracted toward the center of the disc. Also, the angle of blade intersection with a radius of the disc may be altered. They may be advanced toward coincidence with the disc radius or retarded away from it. Further, blade lengths are not all equal. These adjustments affect the spread pattern in the following ways:

1. Advance long blades--more material to the outside of spread pattern; also will increase spread pattern width.
2. Retard long blades--opposite effect of above.
3. Advance short blades—helps eliminate problem of streaking in the middle of spread pattern.
4. Retard short blades—puts more material in the center of spread pattern.
5. Extend blades away from center of spinner—increases spread width somewhat.
6. Retract blades (more towards center of spinner)—opposite effect of above.
7. Moving flow divider (or chute) toward the front of spreader will tend to put more material in center of spread pattern. This is because material is deposited on outer edge of spinner causing it to leave earlier.
8. Moving divider toward the rear of the spreader has the opposite effect.

DISTRIBUTOR BLADE TUNING, MOBILITY

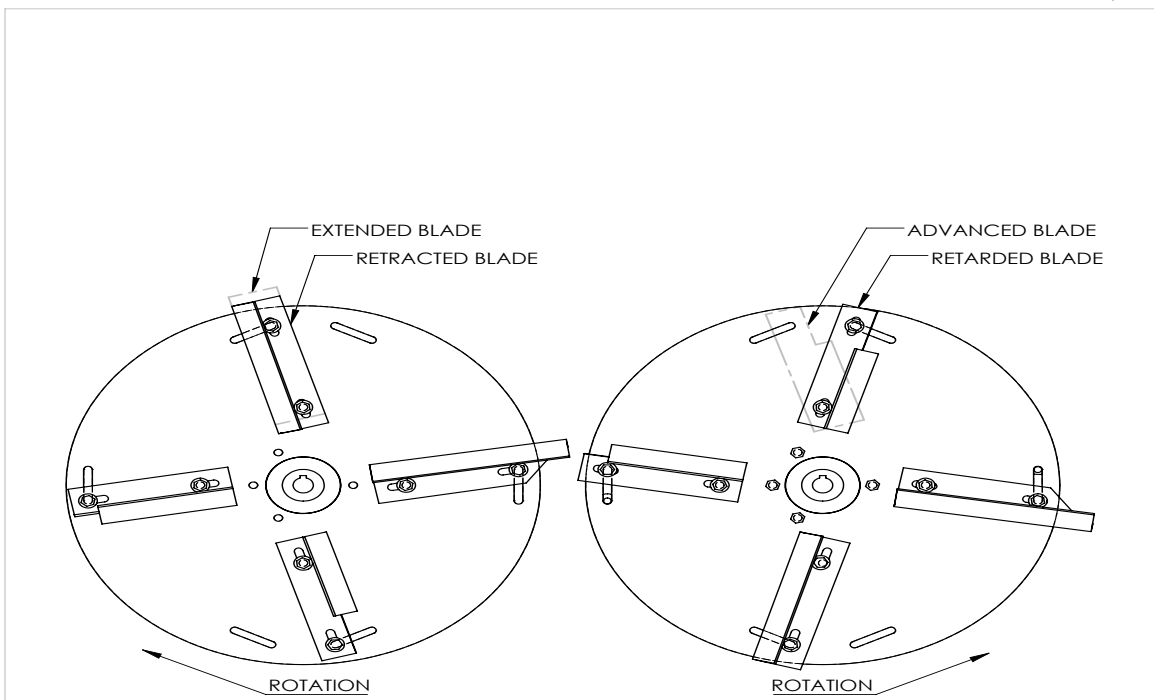

40' SPREAD

NOTICE

APPROXIMATELY 40 FT. SPREAD

800.342.7498

LOW RANGE

12 TO 72 T.

GATE OPENING	MATERIAL WEIGHT IN POUNDS PER CUBIC FOOT							
	40	45	50	55	60	65	70	75
1	55	63	69	76	83	90	96	104
1.5	83	93	103	114	124	135	145	155
2	110	124	138	151	165	179	193	206
2.5	138	155	171	189	206	224	240	258
3	165	186	206	228	248	269	289	310
3.5	193	216	241	265	289	314	338	359
4	220	248	275	303	330	358	385	413
4.5	248	279	310	341	371	403	434	464
5	275	310	344	379	413	448	481	516

HIGH RANGE

24 TO 48 T.

GATE OPENING	MATERIAL WEIGHT IN POUNDS PER CUBIC FOOT							
	40	45	50	55	60	65	70	75
1	165	186	206	228	248	269	290	310
1.5	248	279	310	341	371	404	435	465
2	330	371	413	454	495	538	580	620
2.5	413	464	515	568	619	673	725	775
3	495	558	619	681	743	806	869	930
3.5	578	650	721	794	866	941	1014	1085
4	660	743	825	908	990	1075	1158	1240
4.5	743	836	929	1021	1114	1210	1303	1394
5	825	929	1031	1135	1238	1344	1448	1550

APPLICATION RATE EXPRESSED IN POUNDS PER ACRE



PART NO. 1001118-40

50' SPREAD

NOTICE

APPROXIMATELY 50 FT. SPREAD

800.342.7498

LOW RANGE

12 TO 72 T.

GATE OPENING	MATERIAL WEIGHT IN POUNDS PER CUBIC FOOT							
	40	45	50	55	60	65	70	75
1	44	50	55	61	66	72	77	83
1.5	66	74	82	91	99	108	116	124
2	88	99	110	121	132	143	154	165
2.5	110	124	137	151	165	179	192	206
3	132	149	165	182	198	215	231	248
3.5	154	173	193	212	231	251	270	287
4	176	198	220	242	264	286	308	330
4.5	198	223	248	273	297	322	347	371
5	220	248	275	303	330	358	385	413

HIGH RANGE

24 TO 48 T.

GATE OPENING	MATERIAL WEIGHT IN POUNDS PER CUBIC FOOT							
	40	45	50	55	60	65	70	75
1	132	149	165	182	198	215	232	248
1.5	198	223	248	273	297	323	348	372
2	264	297	330	363	396	430	464	496
2.5	330	371	412	454	495	538	580	620
3	396	446	495	545	594	645	695	744
3.5	462	520	577	635	693	753	811	868
4	528	594	660	726	792	860	926	992
4.5	594	669	743	817	891	968	1042	1115
5	660	743	825	908	990	1075	1158	1240

APPLICATION RATE EXPRESSED IN POUNDS PER ACRE



PART NO. 1001118

FRAME AND DRIVELINE

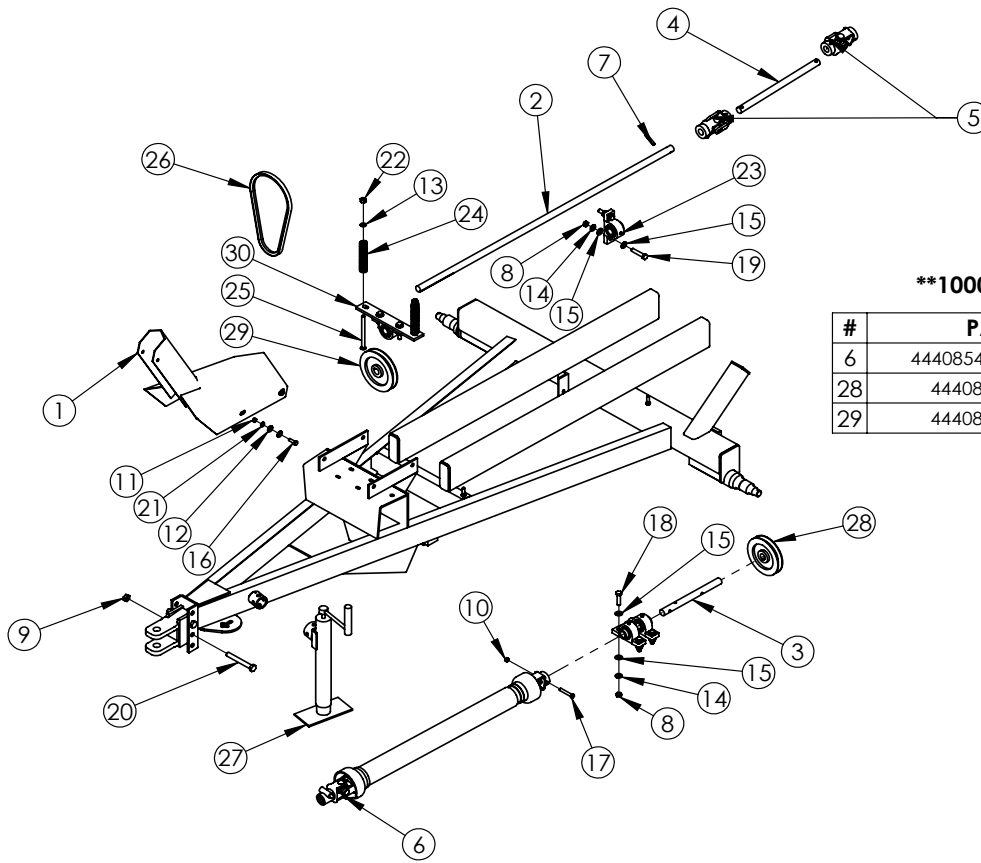

****1000 RPM OPTION****

#	PART NUMBER	Q
6	4440854 1000 RPM PTO SHAFT	1
28	4440827 PULLEY, 4.75 DIA	1
29	4440828 PULLEY, 8.25 DIA	1

#	PART NUMBER	Q
1	MS 1001764 PTO FRONT SHIELD	1
2	MS 4432185 SHAFT, FRONT, 52.5, MOB 100 & 150	1
3	MS 1004197 SHAFT	1
4	4432188 SHAFT, BACK, 1 x 16.75, MOB 100 & 150	1
5	641667 U-JOINT, DRIVE SHAFT	2
6	1009228 PTO COMPLETE, 540 12N	1
7	101689 SPRING PIN .375x2	3
8	150008 NUT, .5 NC, PLTD	8
9	150011 NUT, .625 NC, LOCKING, PLTD	2
10	150022 NUT, .375, LOCKING, PLTD	1
11	150046 NUT, .375 NC SS	4
12	150211 FLAT WASHER, .375	8
13	150212 FLAT WASHER, .375 PLTD	2
14	150218 LOCK WASHER, .5, PLTD	8
15	150220 FLAT WASHER, .5 PLTD	16

#	PART NUMBER	Q
16	151805 BOLT, .375 NC x 1.25, PLTD	4
17	151813 BOLT, .375 NC x 2.5, G5, PLTD	1
18	152210 BOLT .5 x 2 NC PLN	4
19	152212 BOLT .5 x 2.5 NC PLN	4
20	152417 BOLT .625 x 5 NC PLN	2
21	155248 LOCK WASHER, .375	4
22	158039 LOCK NUT, .4375	2
23	640511 PILLOW BLOCK BEARING	4
24	1001636 SPRING	2
25	1001885 CARRIAGE BOLT, .4375 x 6	2
26	1007099 BELT	1
27	4440234 TALL 2000 LBS JACK	1
28	4440829 PULLEY, 6.25 DIA	1
29	4440830 PULLEY, 6.75 DIA	1
30	MS 4432198 BEARING ARM, MOB 100 & 150	1

DRAWN BY	RICH SMOTHERS	9/22/2014
CHECKED BY		
PRINT DATE	11/13/2014	
CONFIG.	FRAME & DRIVELINE	



PROPRIETARY AND CONFIDENTIAL
THE INFORMATION CONTAINED IN THIS DRAWING IS THE SOLE PROPERTY OF DALTON AG. ANY REPRODUCTION IN PART OR AS A WHOLE WITHOUT THE WRITTEN PERMISSION OF DALTON AG IS PROHIBITED.

COMMENTS:

DWG: MOBILITY 100 & 150, FRAME & DRIVELINE

SIZE	SHEET TITLE:	REV
A	Sheet1	A

FOR PARTS, CALL 1.800.342.7498

SCALE: 1:25 SHEET 1 OF 1

540 PTO

1009228 PTO COMPLETE, 540 12N

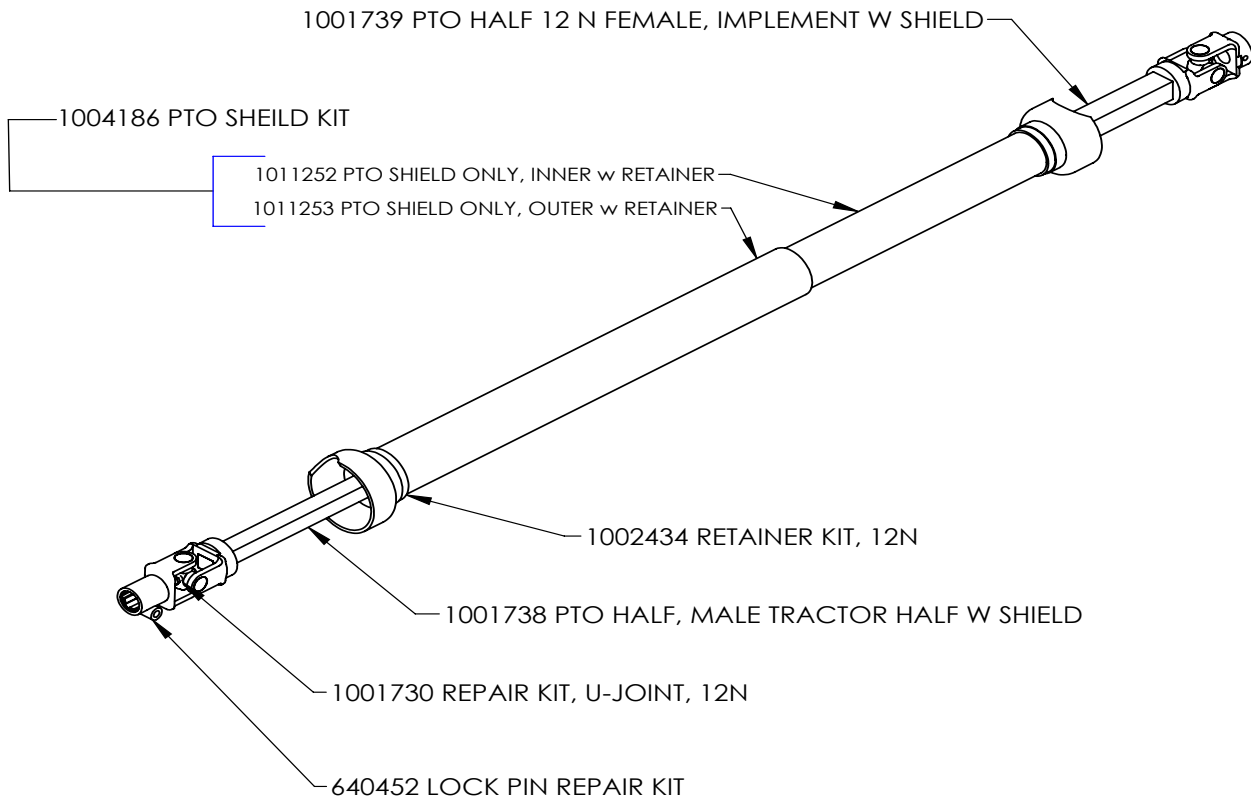

DRAWN BY	RICH SMOTHERS	7/7/2014
CHECKED BY		
PRINT DATE		7/28/2014
CONFIG.	Default	
COMMENTS:		



PROPRIETARY AND CONFIDENTIAL
 THE INFORMATION CONTAINED IN THIS DRAWING IS THE SOLE PROPERTY OF DALTON AG. ANY REPRODUCTION IN PART OR AS A WHOLE WITHOUT THE WRITTEN PERMISSION OF DALTON AG IS PROHIBITED.

DWG: 1009228 540 RPM PTO SHAFT OPTION

SIZE	SHEET TITLE:	REV
A	Sheet1	A
SCALE: 1:10		SHEET 1 OF 1

FOR PARTS, CALL 1.800.342.7498

1000 PTO

4440854 1000 RPM PTO SHAFT

4440854 1000 RPM PTO SHAFT

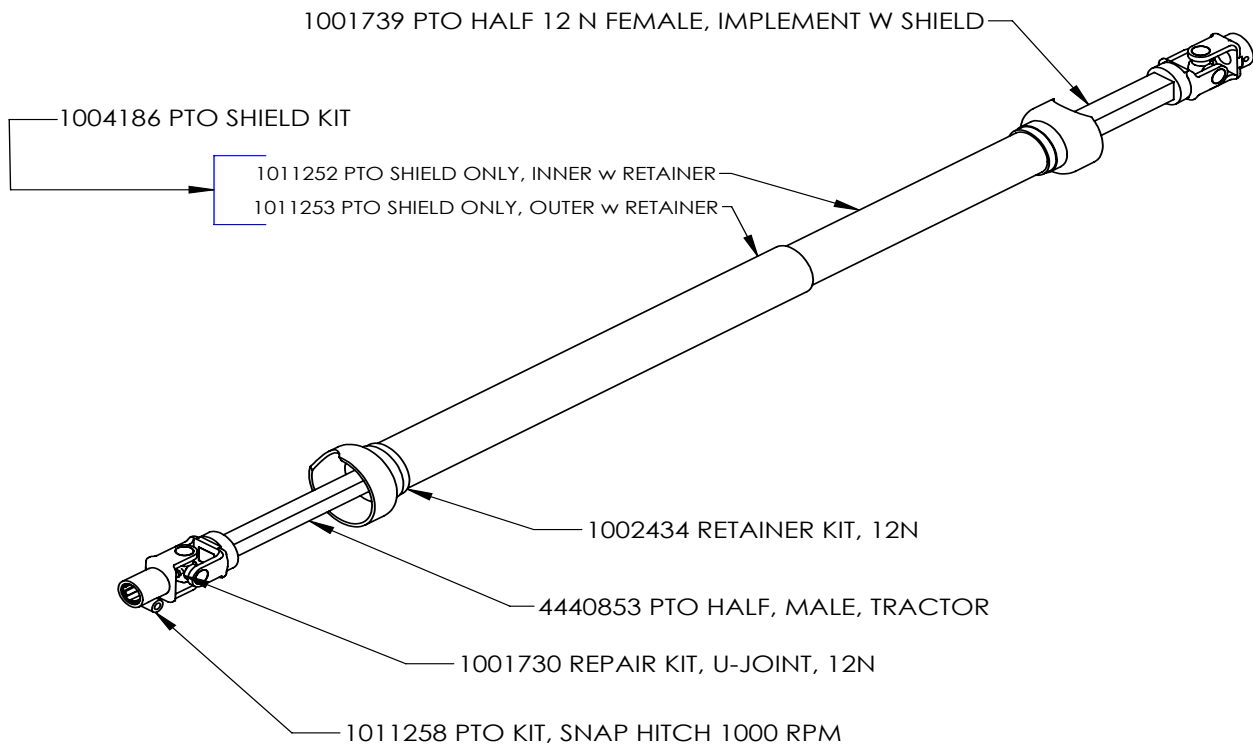

DRAWN BY	RICH SMOTHERS	7/7/2014
CHECKED BY		
PRINT DATE	12/24/2015	
CONFIG.	Default	



PROPRIETARY AND CONFIDENTIAL
 THE INFORMATION CONTAINED IN THIS DRAWING IS THE SOLE PROPERTY OF CMC-DALTON AG. ANY REPRODUCTION IN PART OR AS A WHOLE WITHOUT THE WRITTEN PERMISSION OF CMC-DALTON AG IS PROHIBITED.

COMMENTS:

DWG: 4440854 1000 RPM PTO SHAFT

SIZE A	SHEET TITLE: Sheet1	REV A
------------------	------------------------	-----------------

FOR PARTS, CALL 1.800.342.7498

SCALE: 1:10 SHEET 1 OF 1

6 BOLT, HEAVY HUB ASSEMBLY

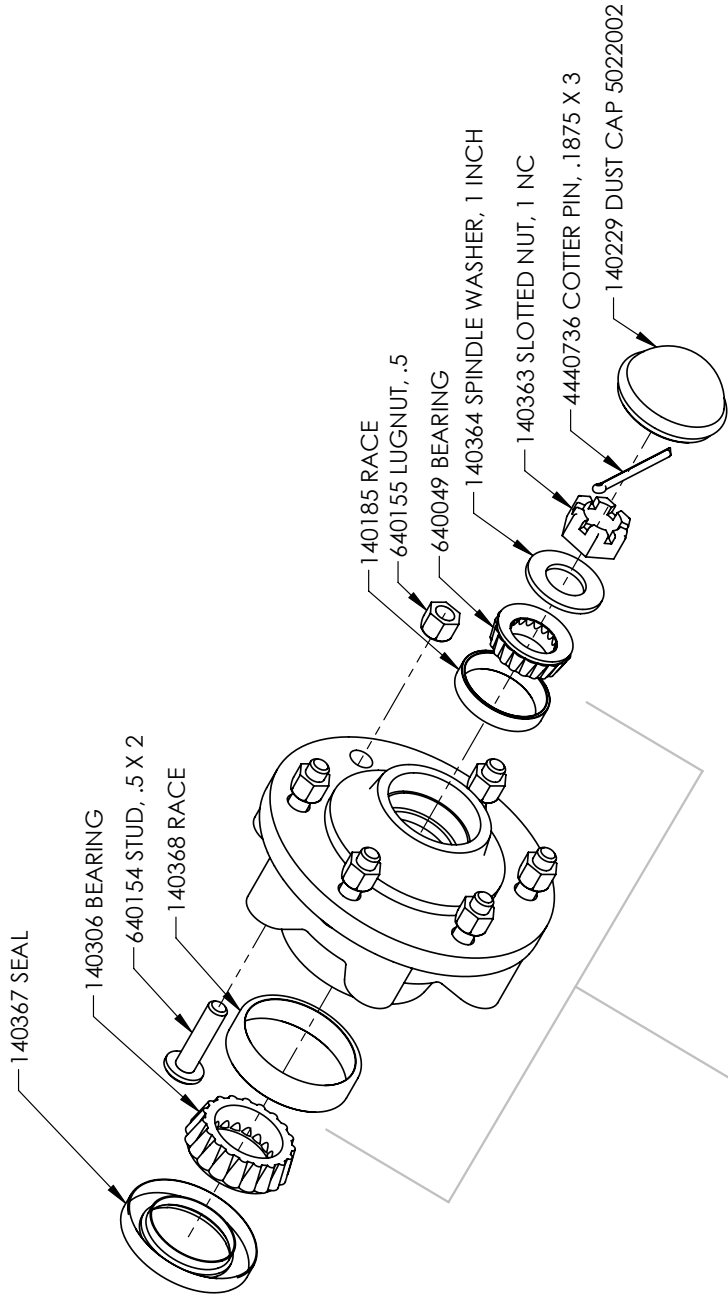

620557 6 BOLT HEAVY HUB W RACES

4410087 6 BOLT HEAVY, HUB ASSEMBLY, COMPLETE

DRAWN BY	RICH SMOTHERS	9/4/2014
CHECKED BY		
PRINT DATE	12/13/2017	
CONFIG.	EXPLODED VIEW	
COMMENTS:		



DWG: 4410087 6 BOLT HEAVY, HUB ASSEMBLY, COMPLETE

SIZE	A	SHEET TITLE:	Sheet1	REV	A
SCALE:	1:4	SHEET 1 OF 1			

PROPRIETARY AND CONFIDENTIAL
 THE INFORMATION CONTAINED IN THIS DRAWING IS THE SOLE PROPERTY OF DALTON AG. ANY REPRODUCTION IN PART OR AS A WHOLE WITHOUT THE WRITTEN PERMISSION OF DALTON AG IS PROHIBITED.

GROUND DRIVE ASSEMBLY

GROUND DRIVE, MOBILITY 100 & 150

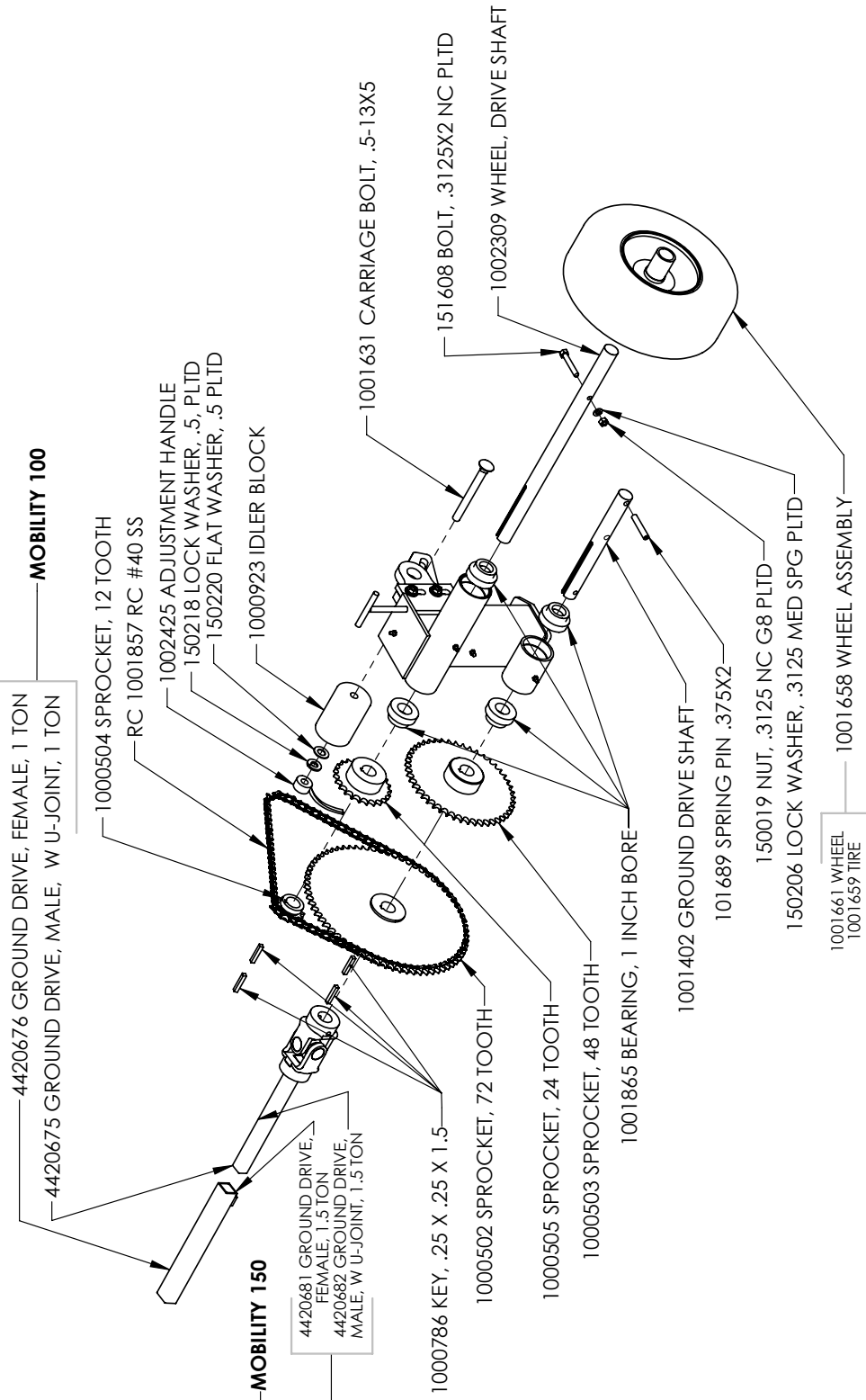

DRAWN BY RICH SMOTHERS CHECKED BY PRINT DATE 2/26/2015 CONFIG. EXPLODED VIEW COMMENTS:	9/22/2014 2/26/2015 EXPLODED VIEW COMMENTS:	DALTON USA 602 E. VAN BUREN ST., LENOX, IA 50851	DWG: GROUND DRIVE, MOBILITY 100 & 150 SIZE SHEET TITLE: Sheet REV A SCALE: 1:10 SHEET 1 OF 1
<p>FOR PARTS, CALL 1.800.342.7498</p>			
5	4	3	2
1			

GROUND DRIVE ASSEMBLY

GROUND DRIVE, 100 & 150, ON-OFF

#	PART NUMBER	Q
1	MS 1005192 HANDLE WELDMENT, GROUND DRIVE, UPPER	1
2	MS 1005191 THREADED ROD WELDMENT, GROUND DRIVE	1
3	MS 4420683 GROUND DRIVE, MANUAL, 100 & 150	1
4	MS 1008046 RETAINER HANDLE WELDMENT, GROUND DRIVE	1
6	1001514 SPRING, GROUND DRIVE	1
6	131017 FLAT WASHER, .75	1
7	120393 WASHER, .3125	2
8	1002478 ROLL PIN, .1875 x 1.5	1
9	1002418 COITER PIN, .0938 x .75	1

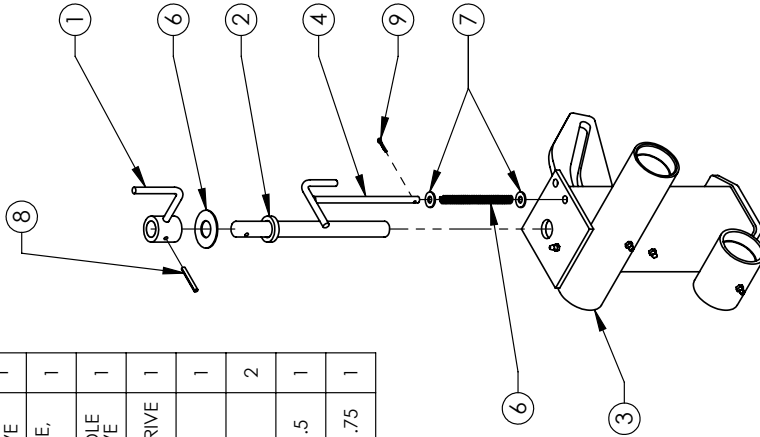

GROUND DRIVE, 100 & 150, MANUAL ON-OFF

ALL QUANTITIES (Q) ARE PER ASSEMBLY

#	PART NUMBER	Q
10	MS 4420482 GROUND DRIVE, HYD, 100 & 150	1
11	4433266 CYLINDER LOCK	1
12	4440884 HYDRAULIC CYLINDER, 2 X 4 X 1.125	1
13	4440865 LOCK PIN, SQUARE WIRE	1
14	4433265 BUSHING, 1.25 SCH 40 X 2	1
17	150211 FLAT WASHER, .375	4
18	151811 BOLT, .375 NC X 2, G5, PLTD	2
19	MS 4433196 ADJUSTABLE LUG, GROUND DRIVE TOP	1
18	155248 LOCK WASHER, .375	2
19	150046 NIUT, .375 NC SS	2

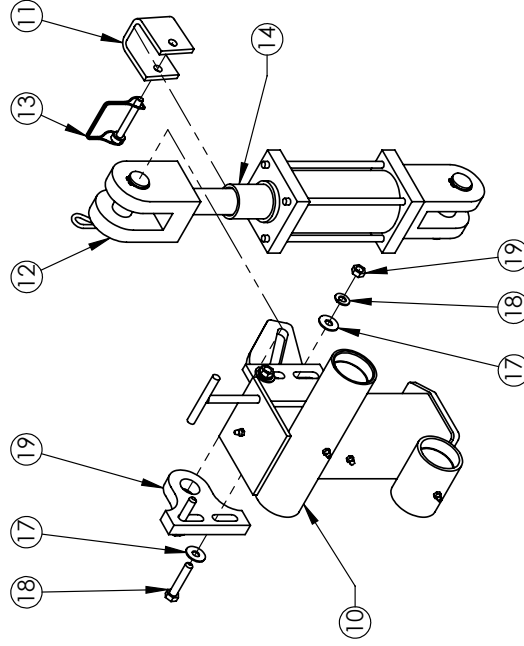

GROUND DRIVE, 100 & 150, HYDRAULIC ON-OFF

DRAWN BY	RICH SMOTHERS	9/22/2014	
CHECKED BY			
PRINT DATE	11/12/2014		
CONFIG.	EXPLODED VIEW		
COMMENTS:	<p>PROPRIETARY AND CONFIDENTIAL THE INFORMATION CONTAINED IN THIS DRAWING IS THE SOLE PROPERTY OF DALTON AG. ANY REPRODUCTION IN PART OR AS A WHOLE WITHOUT THE WRITTEN PERMISSION OF DALTON AG IS PROHIBITED.</p>		
DWG:		GROUND DRIVE, 100 & 150, ON-OFF	
SIZE	SHEET TITLE:	Sheet1	REV
A			A
SCALE: 1:8		SHEET 1 OF 1	

5

4

3

2

1

FRONT TANK ASSEMBLY

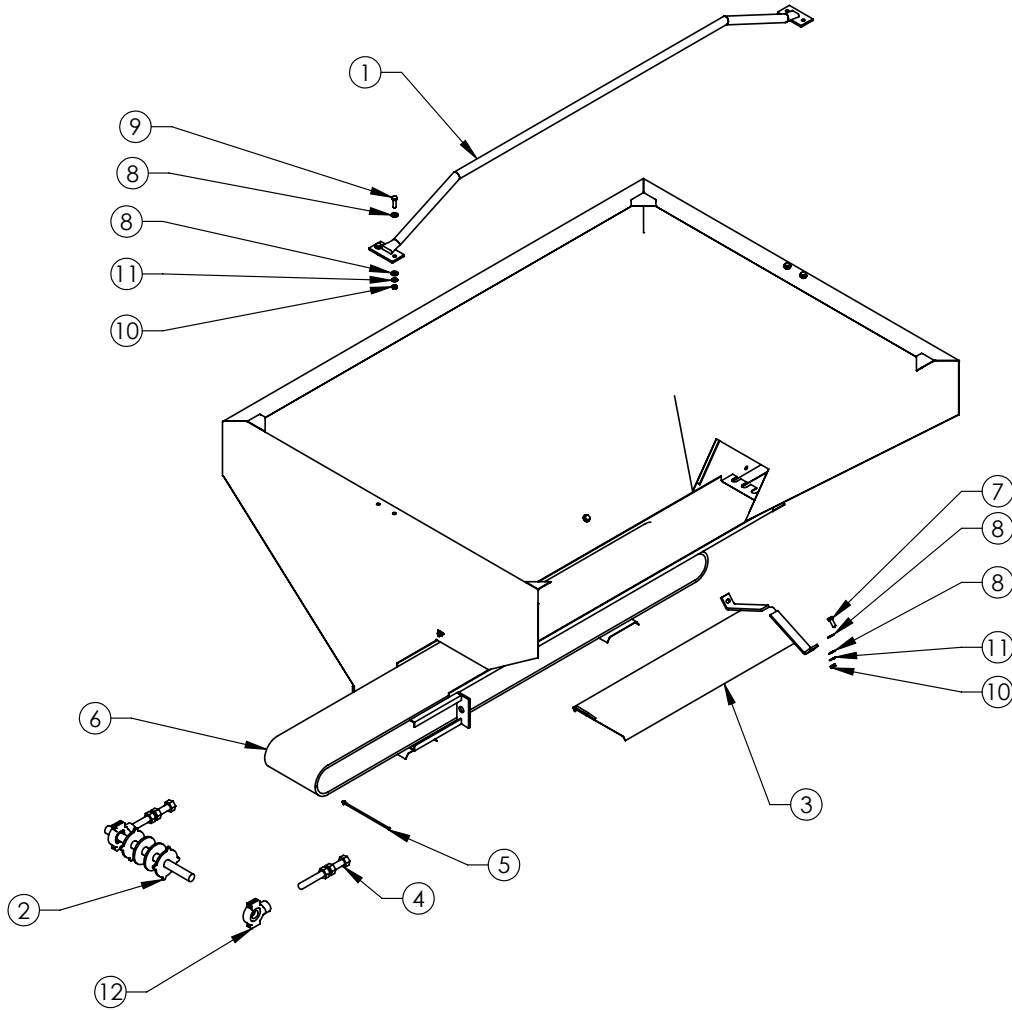

**** FITTED VINYL TARPS ****

PART NUMBER	Q
4440907 TARP, WITH CORD, MOB 100	1
2001129 TARP, WITH CORD, MOB 150	1

#	PART NUMBER	Q
1	MS 4420678 TARP POLE, 100 AND 150	1
2	2001001 FRONT ROLLER	1
3	MS 4420481 CONVEYOR SHIELD, WELDMENT, 100 & 150	1
4	640519 BOLT, TAKE UP	2
5	1000956 CONVEYOR SPLICE PIN	1
6	4440906 DRAG CHAIN, 100, 150 MOB	1
7	120233 BOLT, .375 NC x 1, SS	3
8	150212 FLAT WASHER, .375 PLTD	13
9	158023 BOLT, .375 x 1.5, NC, S.S.	4
10	150046 NUT, .375 NC SS	7
11	155248 LOCK WASHER, .375	7
12	640079 BEARING, TAKE-UP	2

DRAWN BY	RICH SMOTHERS	9/22/2014
CHECKED BY		
PRINT DATE		11/12/2014
CONFIG.	FRONT TANK ASSEMBLY	
COMMENTS:		



PROPRIETARY AND CONFIDENTIAL
THE INFORMATION CONTAINED IN THIS DRAWING IS THE SOLE PROPERTY OF DALTON AG. ANY REPRODUCTION IN PART OR AS A WHOLE WITHOUT THE WRITTEN PERMISSION OF DALTON AG IS PROHIBITED.

DWG: FRONT TANK ASSEMBLY, MOB 100 & 150

SIZE A	SHEET TITLE: Sheet1	REV A
------------------	------------------------	-----------------

FOR PARTS, CALL 1.800.342.7498

SCALE: 1:20 SHEET 1 OF 1

REAR AREA ASSEMBLY

MOBILITY 100 & 150 REAR AREA ASSEMBLY

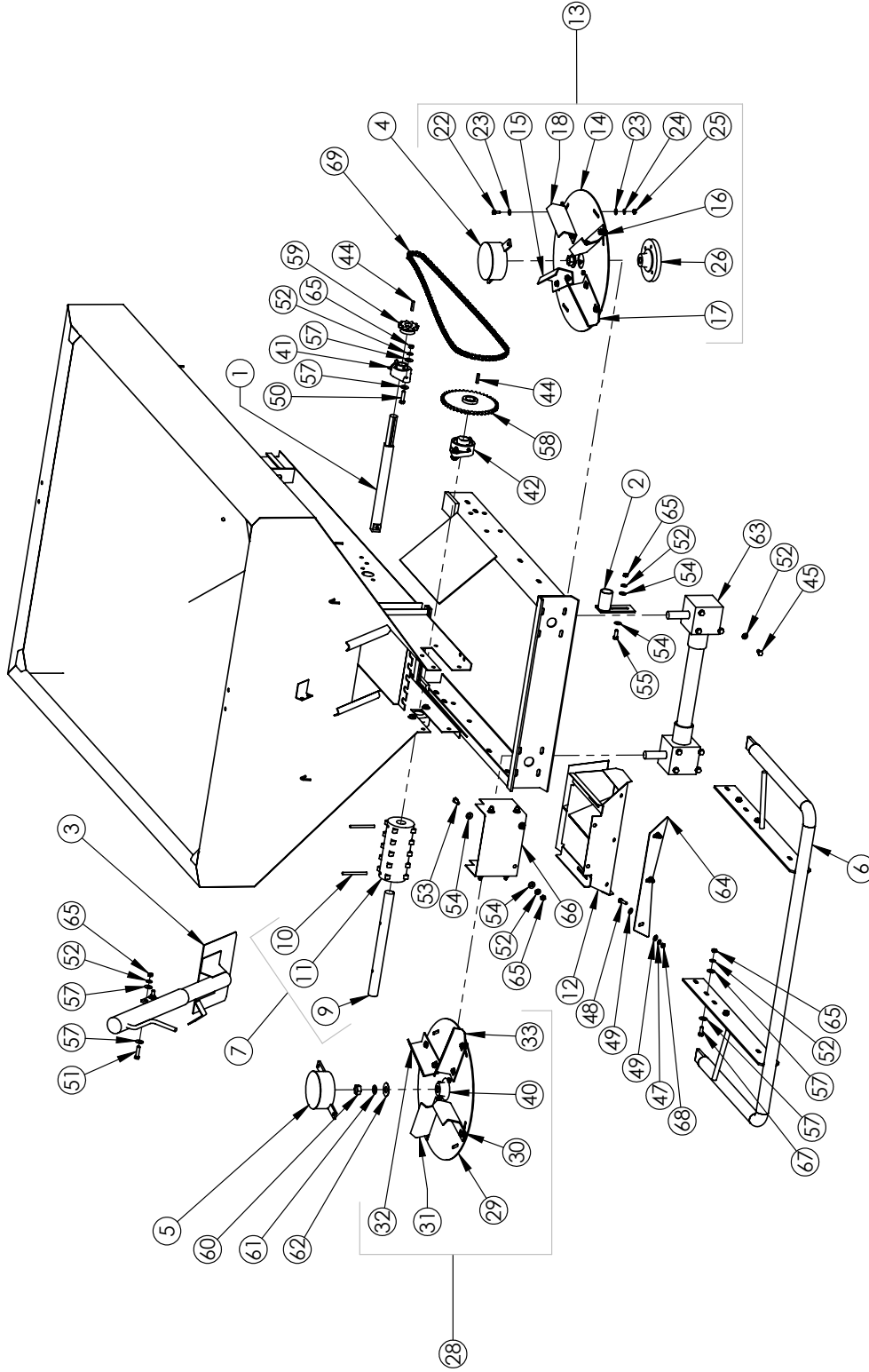

DRAWN BY RICH SMOTHERS 9/22/2014

CHECKED BY

PRINT DATE 2/26/2015

CONFIG. REAR AREA ASSEMBLY

COMMENTS:



DWG: MOBILITY 100 & 150 REAR AREA ASSEMBLY

SIZE SHEET TITLE: Sheet1

REV A

SCALE: 1:20 SHEET 1 OF 2

PROPRIETARY AND CONFIDENTIAL
 THE INFORMATION CONTAINED IN THIS DRAWING IS THE SOLE PROPERTY OF DALTON A.G. ANY REPRODUCTION IN PART OR AS A WHOLE WITHOUT THE WRITTEN PERMISSION OF DALTON A.G. IS PROHIBITED.

FOR PARTS, CALL 1.800.342.7498

5

4

3

2

1

REAR AREA ASSEMBLY, 100 & 150 SERIES SPREADERS

#	PART NUMBER	Q
1	4420681 GROUND DRIVE, FEMALE, 1.5 TON	1
1A	4420676 GROUND DRIVE, FEMALE, 1 TON	1
2	1000961 #50 CHAIN IDLER WELDMENT	1
3	1004557 GATE JACK WELDMENT	1
4	1001717 DISC CAP WELDMENT R.H.	1
5	1001716 DISC CAP WELDMENT L.H	1
6	1008033 BUMPER WELDMENT	1
7	1000838 DRIVE SPROCKET ASSEMBLY	1
9	1000644 SPROCKET SHAFT	1
10	158035 ROLL PIN .3125 x 3.5	2
11	1000684 CAST SPROCKET, MACHINED	1
12	MS 1001379 DIVIDER WELDMENT	1
13	1003734 DISTRIBUTOR DISC ASSEMBLY, RH	1
14	1003727 DISTRIBUTOR DISC	1
15	MS 1001718 7 INCH DISTRIBUTOR BLADE, RIGHT	1
16	MS 1001924 4.375 DISTRIBUTOR BLADE, RIGHT	1
17	MS 1001662 EXTRA LONG DISTRIBUTOR BLADE, 8, RIGHT	1
18	MS 1001926 DISTRIBUTOR BLADE, 5.5, RIGHT	1
19	151603 .3125x1 NC PLTD BOLT	4
20	150209 LOCK WASHER, .375, PLTD	4
21	150019 NUT, .3125 NC G8 PLTD	4
22	151407 BOLT, .25 NC x .75 PLTD	6
23	150204 FLAT WASHER, .25 PLTD	16
24	150202 LOCK WASHER, .25 PLTD	8
25	150024 NUT, .25 NC, PLTD	8
26	1003709 SPINNER HUB, STANDARD	1
27	151419 BOLT, .25x1.25 HH NC PLTD	2
28	1003733 DISTRIBUTOR DISC ASSEMBLY, L.H.	1
29	1003727 DISTRIBUTOR DISC	1
30	MS 1001925 4.375 DISTRIBUTOR BLADE, LEFT	1
31	MS 1001927 DISTRIBUTOR BLADE, 5.5, LEFT	1
32	MS 1001719 7 INCH DISTRIBUTOR BLADE, LEFT	1
33	MS 1001705 EXTRA LONG DISTRIBUTOR BLADE, 8, LEFT	1
34	150019 NUT, .3125 NC G8 PLTD	12
35	150209 LOCK WASHER, .375, PLTD	4
36	151602 BOLT .3125 x .75 NC PLTD	10
37	1010175 BOLT .3125 x 1 NC	2
38	150208 WASHER, .3125 STD Z PLTD	16
39	150206 LOCK WASHER, .3125 MED SPG PLTD	8
40	1003709 SPINNER HUB, STANDARD	1
41	640034 BEARING, 1 INCH BORE 2-BOLT	1
42	1000646 BEARING, 1.25 BORE 2-BOLT FLANGE	2
44	641653 KEY, .25 x .25 x 1.25	2
45	151801 BOLT, .375 NC x .75, PLTD	8
47	150206 LOCK WASHER, .3125 MED SPG PLTD	3
48	151603 .3125x1 NC PLTD BOLT	3
49	150208 WASHER, .3125 STD Z PLTD	9
50	151807 BOLT .375 x 1.5 NC PLN	6
51	151806 BOLT, .375 NC x 1.5, G5, PLTD	2
52	150209 LOCK WASHER, .375, PLTD	27
53	120233 BOLT, .375 NC x 1, SS	6
54	150212 FLAT WASHER, .375 PLTD	14
55	151802 BOLT, .375 NC x 1, PLTD	1
57	150211 FLAT WASHER, .375	21
58	1000507 SPROCKET 50B36	1
59	1000506 SPROCKET, 50B12	1
60	150124 NUT, NF, SS	2
61	150226 LOCK WASHER, .75, PLTD	2
62	150227 FLAT WASHER, .75 PLTD	2
63	1003737 GEAR BOX SET	1
64	MS 1001501 DIVIDER	1
65	150046 NUT, .375 NC SS	19
66	MS 4432191 TROUGH BACK	1
67	150614 BOLT, .375x1 NC PLTD	4
68	1001633 LOCK NUT, .3125	3
69	1001455 CHAIN #50	1

**** 1004466 DISTRIBUTOR BLADE SET **
INCLUDES BOTH RIGHT SIDE
AND LEFT SIDE BLADES.**

DRAWN BY	RICH SMOTHERS
CHECKED BY	
PRINT DATE	
CONFIG.	



PROPRIETARY AND CONFIDENTIAL
THE INFORMATION CONTAINED IN THIS DRAWING IS THE SOLE PROPERTY OF DALTON AG. ANY REPRODUCTION IN PART OR AS A WHOLE WITHOUT THE WRITTEN PERMISSION OF DALTON AG IS PROHIBITED.

COMMENTS:	
-----------	--

DWG:	MOBILITY 100 & 150 REAR AREA ASSEMBLY	
SIZE	SHEET TITLE:	REV
A	Sheet2	A

FOR PARTS, CALL 1.800.342.7498

SCALE: 1:20 SHEET 2 OF 2

1003737, DISTRIBUTOR GEAR BOX

ITEM	PART #	DESCRIPTION	QTY
1	1003735	BOX ASSEMBLY, RH	1
2	1000938	PLUG, SOFT	2
3	1000932	BEARING	8
4	1002426	GEAR	2
5	1000936	HOUSING, RH	1
6	1006856	OIL PLUG	2
7	1000935	KEY, WOODRUFF	2
8	1003730	SHAFT, TAPERED	1
9	1000933	RETAINER RING	5
10	1000931	RETAINER RING	8
11	1000930	SEAL	3
12	1001206	TUBE ASSEMBLY	1
13	1000944	HOUSING BARREL	3
14	1000941	TUBE ASSEMBLY	1
15	1002417	SHAFT, TAPERED	1
16	1000945	PINION GEAR	2
17	1003736	BOX ASSEMBLY, LH	1
18	1003730	SHAFT, TAPERED	1
19	1000947	HOUSING, LH	1
20	1001205	BARREL ASSEMBLY	1
21	1000948	SHAFT & GEAR ASSEMBLY	1
22	1000940	GASKET	3
23	1000834	HHCS, 5/16-18 x 3/4"	12
24	1000836	LOCK WASHER, 5/16"	12
25	1003742	45 DEGREE GREASE ZERK	2

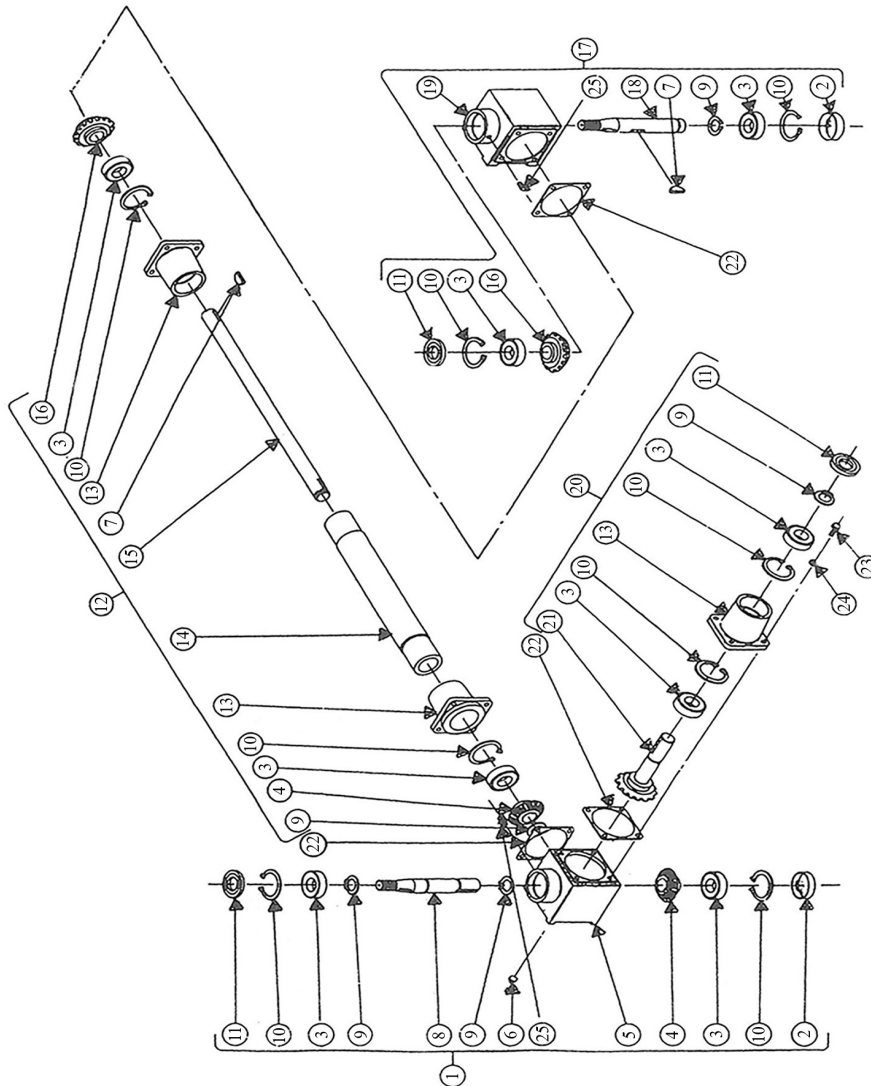

HYDRAULIC SPINNER GEAR BOX

ROW CROP HYD SPINNERS

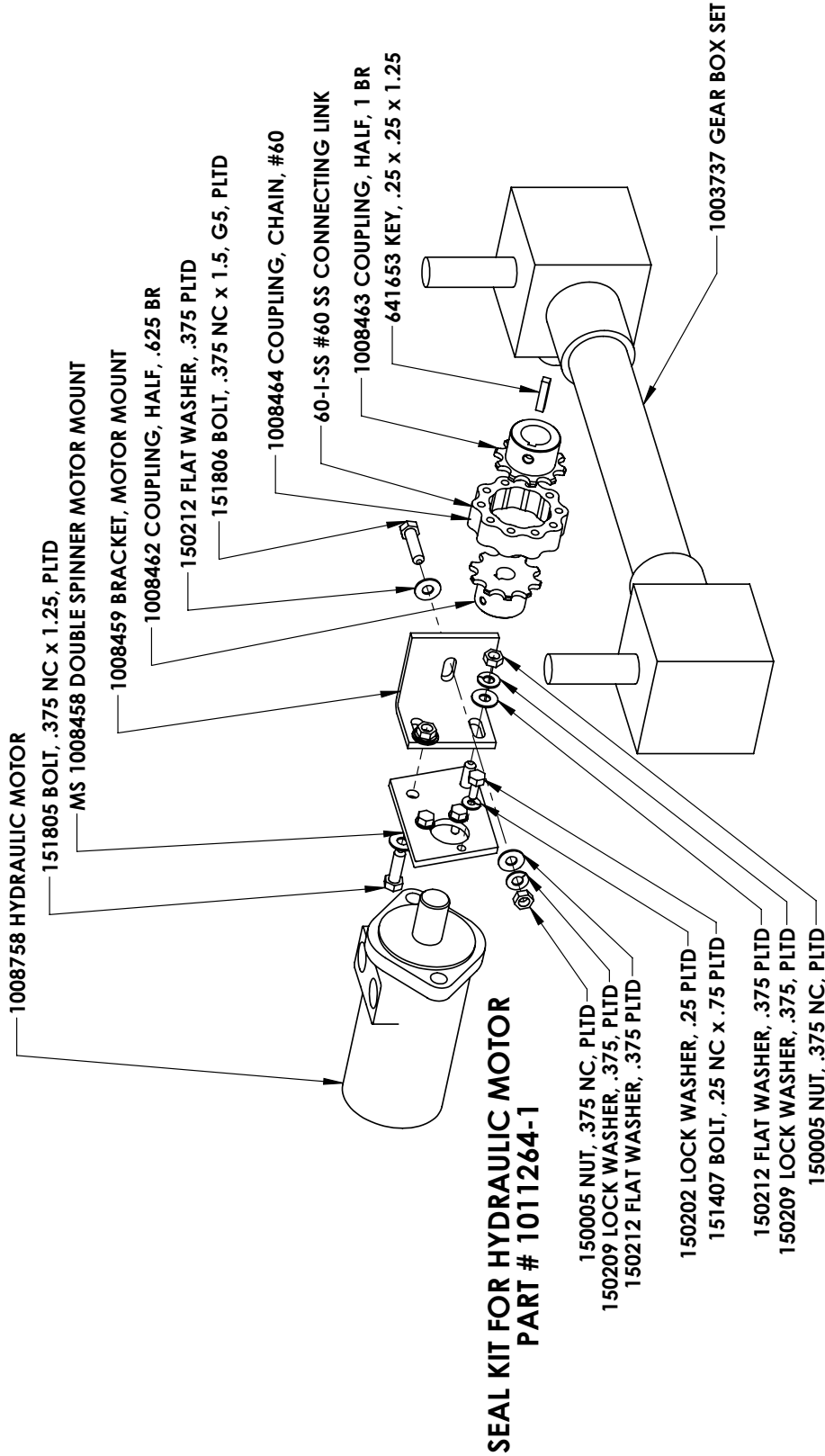

DRAWN BY RICH SMOTHERS 4/3/2013

CHECKED BY

PRINT DATE 7/28/2014

CONFIG. Default

COMMENTS:



DWG: ROW CROP HYD SPINNERS

SIZE SHEET TITLE: Sheet1 REV A

SCALE: 1:5 SHEET 1 OF 1

PROPRIETARY AND CONFIDENTIAL
THE INFORMATION CONTAINED IN THIS DRAWING IS THE SOLE PROPERTY OF DALTON AG. ANY REPRODUCTION IN PART OR AS A WHOLE WITHOUT THE WRITTEN PERMISSION OF DALTON AG IS PROHIBITED.

FOR PARTS, CALL 1.800.342.7498

TRACTOR HYDRAULIC DRIVEN SPINNERS

TRACTOR HYDRAULIC DRIVEN SPINNERS, ROW CROP

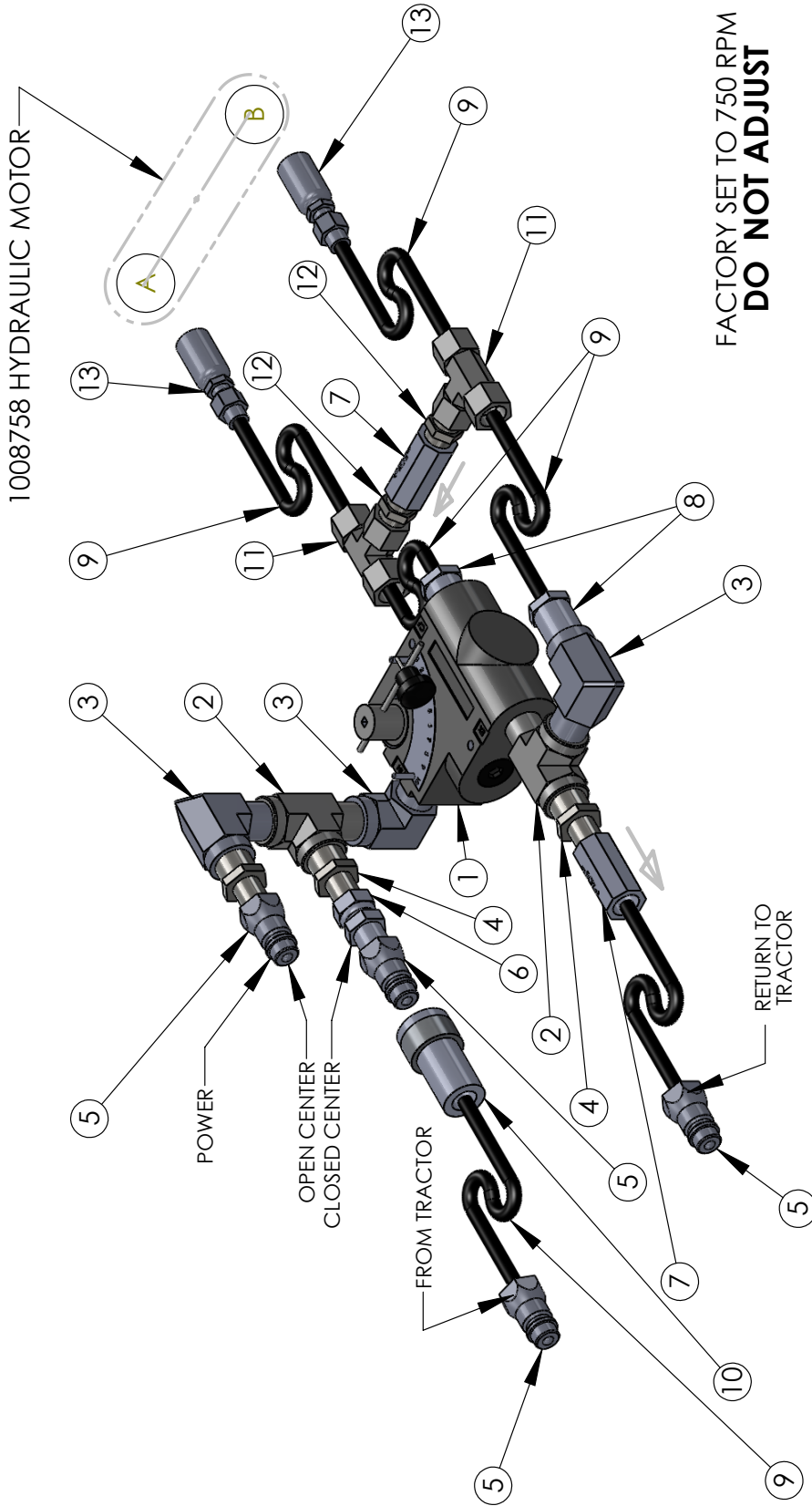

DRAWN BY	RICH SMOTHERS	9/12/2009		
CHECKED BY				
PRINT DATE	7/28/2014			
CONFIG.	Default			
COMMENTS:	<p>PROPRIETARY AND CONFIDENTIAL THE INFORMATION CONTAINED IN THIS DRAWING IS THE SOLE PROPERTY OF DALTON AG. ANY REPRODUCTION IN PART OR AS A WHOLE WITHOUT THE WRITTEN PERMISSION OF DALTON AG IS PROHIBITED.</p>			
DWG:	TRACTOR HYDRAULIC DRIVEN SPINNERS, ROW CROP			
SIZE	A	SHEET TITLE:	SCHEMATIC	REV
SCALE:	1:4			A
FOR PARTS, CALL 1.800.342.7498			SHEET 1 OF 2	
	3	2	1	5

VARIABLE RATE CONTROL, ELECTRICAL PLAN

SCS 660 WITH MASTER SWITCH GRANULAR CONTROL SYSTEM

CONTROL CONSOLE W/ MASTER SWITCH
SCS 660: 063-0172-542

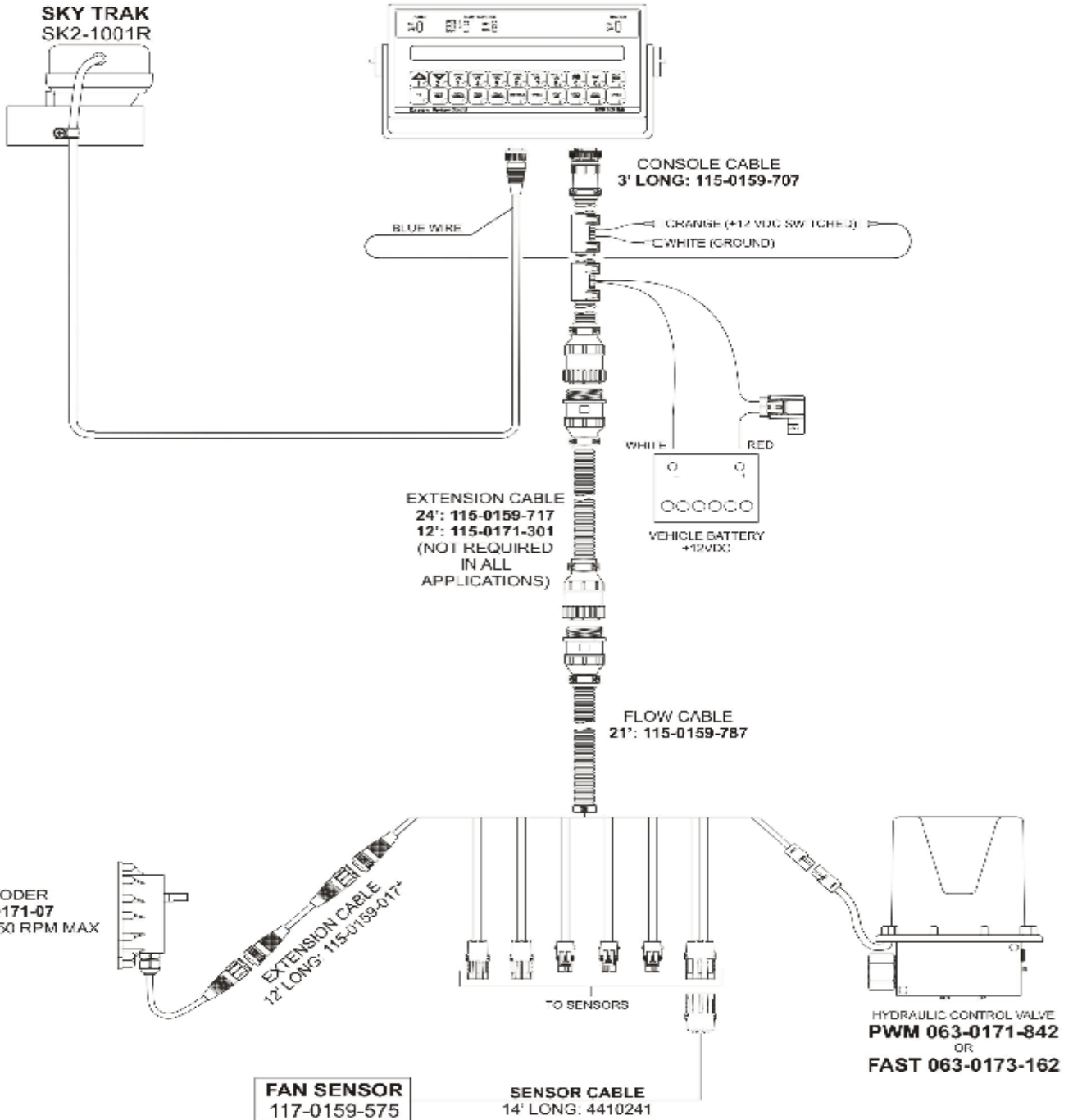

DRAWN BY	RICH SMOTHERS
CHECKED BY	
PRINT DATE	
CONFIG.	
COMMENTS:	



PROPRIETARY AND CONFIDENTIAL
THE INFORMATION CONTAINED IN THIS DRAWING IS THE SOLE PROPERTY OF CMC-DALTON AG. ANY REPRODUCTION IN PART OR AS A WHOLE WITHOUT THE WRITTEN PERMISSION OF CMC-DALTON AG IS PROHIBITED.

DWG: VARIABLE RATE CONTROL, ELECTRICAL PLAN

SIZE	SHEET TITLE:	REV
A	ELECTRICAL PLUMBING	A
SCALE: 1:10	SHEET 1 OF 1	

FOR PARTS, CALL 1.800.342.7498

CONVEYOR CLUTCH OPTION

#	PART NUMBER	QUANTITY
1	640034 BEARING, 1 INCH BORE 2-BOLT	1
2	640034 BEARING, 1 INCH BORE 2-BOLT	1
3	150212 FLAT WASHER, .375 PLTD	9
4	150046 NUT, .375 NC SS	5
5	4420692 ARM WELDMENT, SHORT	1
6	4432204 CROSS SHAFT	1
7	4420691 ENGAGING ARM WELDMENT, SHORT	1
8	1001975 TRIP ARM WELDMENT	1
9	1000523-100 DRIVE SHAFT	1
10	Backup of 158015 ROLL PIN, .3125 x 2	1
11	155248 LOCK WASHER, .375	2
12	1001954 DRIVE JAW, WELDMENT	1
13	1001957 BUSHING, SHIFTING FORK CLUTCH	2
14	150201 LOCK WASHER, .25 MED SPG PLN	2
15	1001959 BEARING, .50 BORE 2 BOLT FLANGE	1
16	150024 NUT, .25 NC, PLTD	2
17	151419 BOLT, .25x1.25 HH NC PLTD	2
18	150204 FLAT WASHER, .25 PLTD	4
19	150218 LOCK WASHER, .5, PLTD	1
20	151802 BOLT, .375 NC x 1, PLTD	1
21	150005 NUT, .375 NC, PLTD	3
22	1001958 BUSHING, SHIFTING ARM, CLUTCH	2
23	151805 BOLT, .375 NC x 1.25, PLTD	2
24	152003 BOLT .4375 x 1.25 NC PLTD	1
25	150220 FLAT WASHER, .5 PLTD	2
26	150021 NUT, .4375 NC PLATED	1
27	150217 LOCK WASHER, .5	1
28	3 CHAIN LINK	1
29	1001522 EXTENSION SPRING, .75 x 12.5	1
30	151809 BOLT .375 x 1.75 NC Z PLTD	2
31	150248 LOCK WASHER, .375 STD SS	6
32	158023 BOLT, .375 x 1.5, NC, S.S.	3
33	152249 BOLT .5 x 1.5 NC GRD 5 PLTD	1
34	1004324 PULLEY, SINGLE SHEAVE, 1.5 INCH	1

*****ITEM NO. 9 FOR MOBILITY 150: 1000523-150 DRIVE SHAFT*****

1001969 CLUTCH JAW ASSEMBLY: INCLUDES ITEM NOS. 12, 14, 15, 16, 19 & 33

DRAWN BY	RICH SMOTHERS
CHECKED BY	
PRINT DATE	
CONFIG.	
COMMENTS:	



PROPRIETARY AND CONFIDENTIAL
THE INFORMATION CONTAINED IN THIS DRAWING IS THE SOLE PROPERTY OF DALTON AG. ANY REPRODUCTION IN PART OR AS A WHOLE WITHOUT THE WRITTEN PERMISSION OF DALTON AG IS PROHIBITED.

DWG: CONVEYOR CLUTCH OPTION

SIZE A	SHEET TITLE: Sheet2	REV A
------------------	------------------------	-----------------

FOR PARTS, CALL 1.800.342.7498

SCALE: 1:6 SHEET 2 OF 2

CONVEYOR CLUTCH OPTION MOBILITY 100 & 150

CONVEYOR CLUTCH OPTION

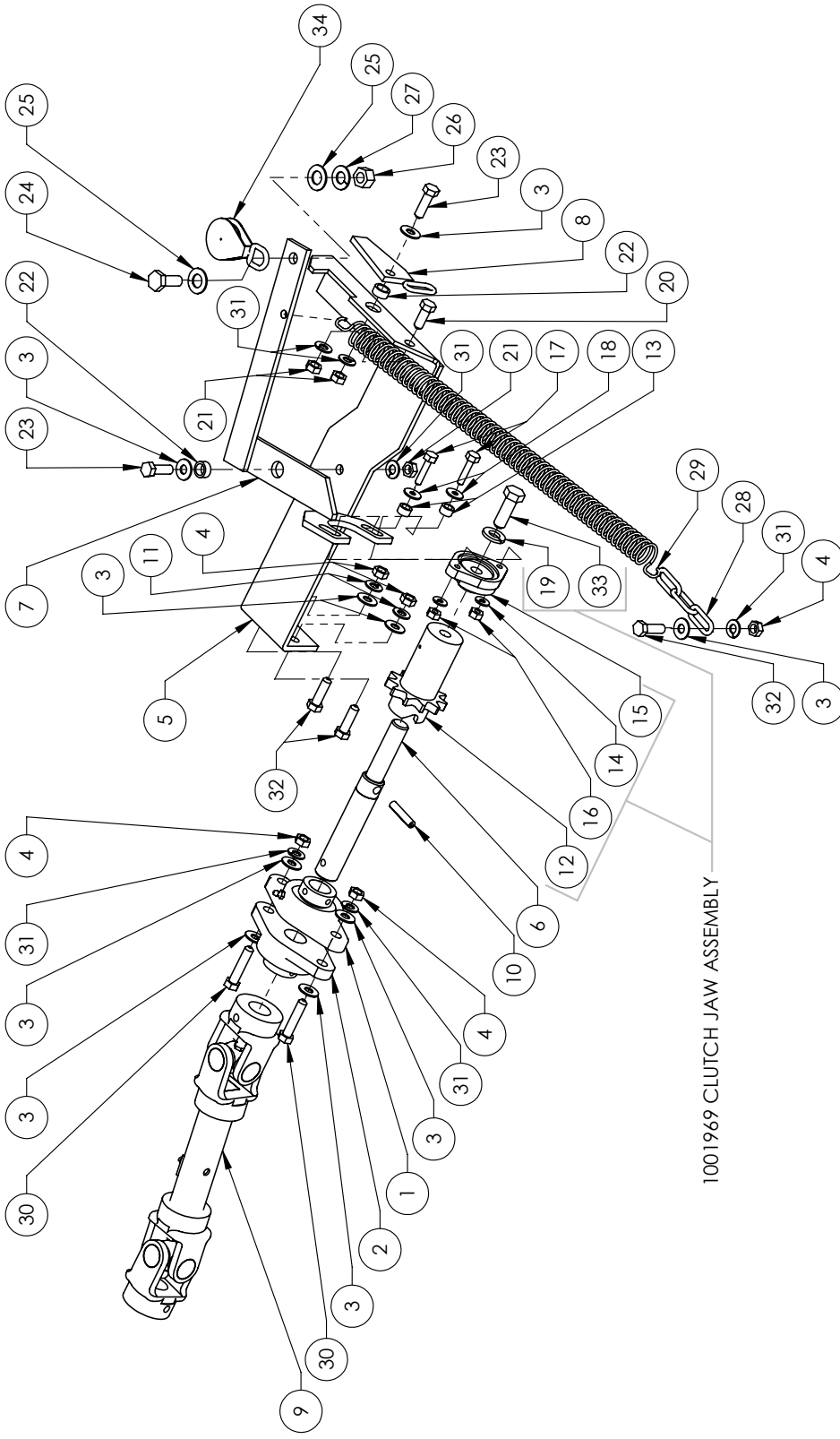

1001969 CLUTCH JAW ASSEMBLY

DRAWN BY: RICH SMOTHERS CHECKED BY: PRINT DATE: 3/2/2015 CONFIG.: REMOTE CLUTCH COMMENTS:	10/22/2014 3/2/2015	DALTON CONVEYOR SYSTEMS 602 E. VAN BUREN ST., LENOX, IA 50851	DWG: CONVEYOR CLUTCH OPTION SIZE: A SHEET TITLE: Sheet1 REV: A
PROPRIETARY AND CONFIDENTIAL THE INFORMATION CONTAINED IN THIS DRAWING IS THE SOLE PROPERTY OF DALTON AG. ANY REPRODUCTION IN PART OR AS A WHOLE WITHOUT THE WRITTEN PERMISSION OF DALTON AG IS PROHIBITED.		SCALE: 1:6 SHEET 1 OF 2	
FOR PARTS, CALL 1.800.342.7498			

ITEM NO.	PART NUMBER	QTY.
1	FC51-3 4, HYDRAULIC REGULATOR	1
2	5602-12 T COUPLER, F-F-M, .75 INCH NPT	2
3	5502-12 ST ELBOW, 90 DEGREE, .5 INCH	3
4	540412-8, 2 INCH ADAPTER, .5INCH-.75 INCH NPT	3
5	8010-4 PIONEER FITTING, .5 INCH	4
6	641679 RESTRICTOR, .06, .5 INCH NPT	1
7	PMR10 CHECK VALVE, .5 INCH NPT	2
8	140412-8 ADAPTER, .5-.75 INCH NPT	2
9	HOSE, .375 INCH	6
10	4050-12 PIONEER FITTING, FEMALE, .5 INCH NPT	1
11	1603-8-8 T COUPLER, .5 INCH NPT	2
12	5404-8, 2 INCH NIPPLE, .5INCH NPT	2
13	.5 O RING FITTING	2



DWG: TRACTOR HYDRAULIC DRIVEN SPINNERS, ROW CROP, p2

SIZE SHEET TITLE: BILL OF MATERIALS REV A

SCALE: 1:4 SHEET 1 OF 1

DRAWN BY RICH SMOTHERS
 CHECKED BY
 PRINT DATE
 CONFIG.
 COMMENTS:





PROPRIETARY AND CONFIDENTIAL
 THE INFORMATION CONTAINED IN THIS DRAWING IS THE SOLE PROPERTY OF DALTON AG. ANY REPRODUCTION IN PART OR AS A WHOLE WITHOUT THE WRITTEN PERMISSION OF DALTON AG IS PROHIBITED.

FOR PARTS, CALL 1.800.342.7498

5 4 3 2 1

IMPORTANT : Over tightening hardware can be as damaging as under tightening. Tightening beyond recommended torque will reduce the fastener's shock load capacity.

BOLT TORQUE CHART

SIZE	 SAE GRADE 2		 SAE GRADE 5		 SAE GRADE 8		 L9
	ASSEMBLY TORQUE		ASSEMBLY TORQUE		ASSEMBLY TORQUE		ASSEMBLY TORQUE
	DRY	LUBRICATED	DRY	LUBRICATED	DRY	LUBRICATED	LUBRICATED
1/4-20	66*	49*	8	75*	12	9	11
1/4-28	76*	56*	10	86*	14	10	13
5/16-18	11	8	17	13	20	18	21
5/16-24	12	9	19	14	25	20	23
3/8-16	20	15	30	23	45	30	33
3/8-24	23	17	35	25	50	35	38
7/16-14	30	24	50	35	70	55	60
7/16-20	35	25	55	40	80	60	65
1/2-13	50	35	75	55	110	80	95
1/2-20	55	40	90	65	120	90	105
9/16-12	65	50	110	80	150	110	140
9/16-18	75	55	120	90	170	130	150
5/8-11	90	70	150	110	220	170	185
5/8-18	100	80	180	130	240	180	205
3/4-10	160	120	260	200	380	280	290
3/4-16	180	140	300	220	420	320	355
7/8-9	190	140	400	300	600	460	505
7/8-14	210	155	440	320	660	500	585
1-8	220	160	580	440	900	680	775
1-14	240	170	640	480	1000	740	900
1 1/8-7	300	220	800	600	1280	960	1150
1 1/8-12	340	260	880	660	1440	1080	1325
1 1/4-7	420	320	1120	840	1820	1360	1600
1 1/4-12	460	360	1240	920	2000	1500	1750
1 3/8-6	560	420	1460	1100	2380	1780	---
1 3/8-12	640	460	1680	1260	2720	2040	---
1 1/2-6	740	560	1940	1460	3160	2360	3250
1 1/2-12	840	620	2200	1640	3560	2660	3650

**ITEMS WITH * = INCH POUNDS
ALL OTHERS = FOOT POUNDS**

WARNING: Never work around any raised implement while in the raised position without using safety lockups.

VARIABLE RATE CONTROL, HYDRAULIC PLAN

VARIABLE RATE CONTROL, HYDRAULIC PLAN

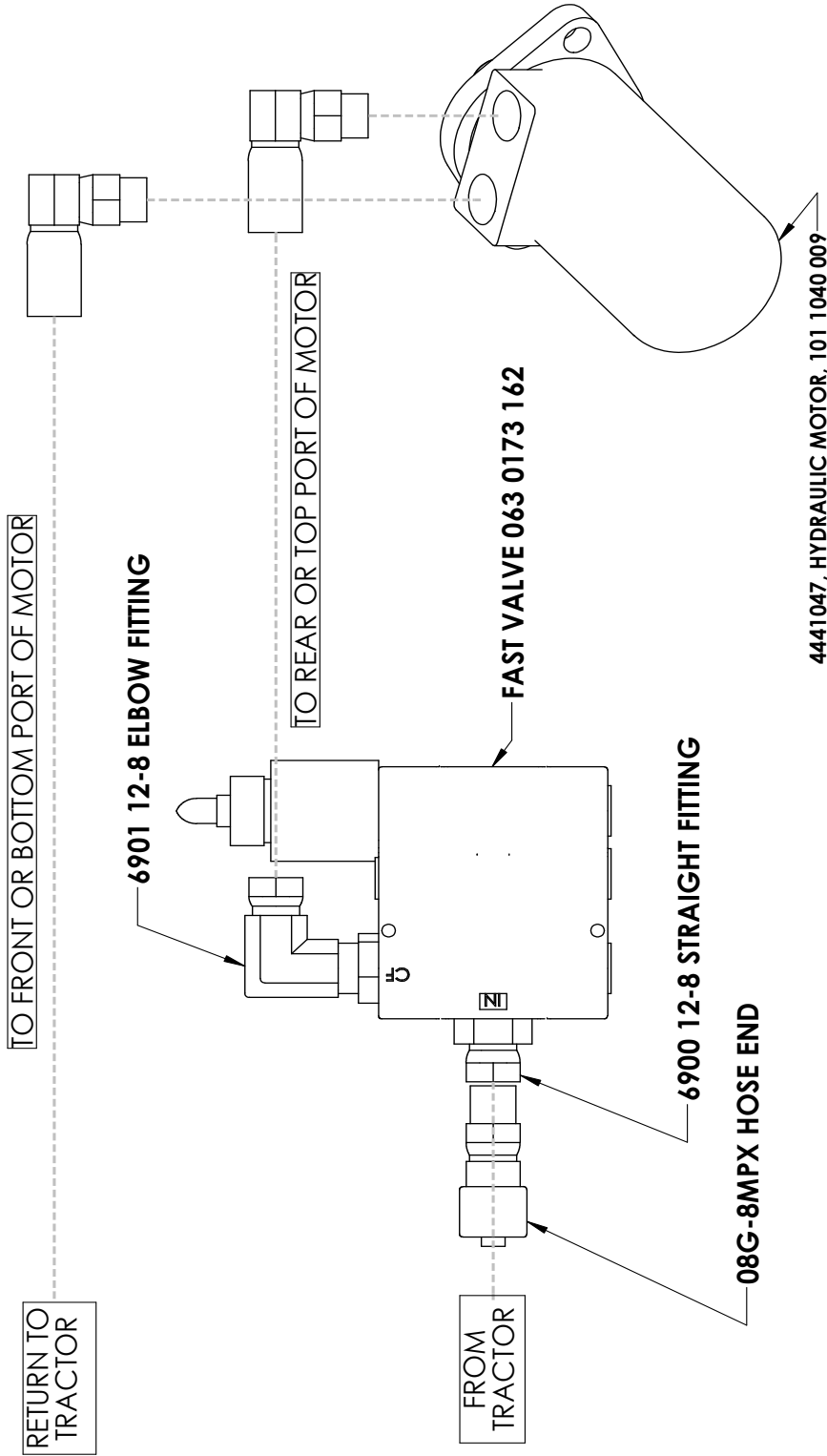

DRAWN BY	RICH SMOTHERS	4/12/2012	 602 E. VAN BUREN ST., LENOX, IA 50851	
CHECKED BY				
PRINT DATE	4/11/2017		DWG: VARIABLE RATE CONTROL, HYDRAULIC PLAN	
CONFIG.	FOR DWG		SIZE SHEET TITLE: HYDRAULIC PLUMBING REV A	
COMMENTS:	PROPRIETARY AND CONFIDENTIAL THE INFORMATION CONTAINED IN THIS DRAWING IS THE SOLE PROPERTY OF DALTON A.G. ANY REPRODUCTION IN PART OR AS A WHOLE WITHOUT THE WRITTEN PERMISSION OF DALTON A.G. IS PROHIBITED.		SCALE: 1:3 SHEET 1 OF 1	
FOR PARTS, CALL 1.800.342.7498			5	1

BANDER OPTION

MOBILITY 100 & 150 ADD-ONS

#	PART NUMBER	Q
1	MS 4432193 MOB. 100 EXTENSION, FRONT & BACK	2
2	MS 4432194 100 & 150 SIDE EXTENSION	2
3	MS 4432195 EXTENSION BRACKET	4
4	150212 FLAT WASHER, .375 PLTD	76
5	120233 BOLT, .375 NC X 1, SS	38
6	155248 LOCK WASHER, .375	38
7	150046 NUT, .375 NC SS	38

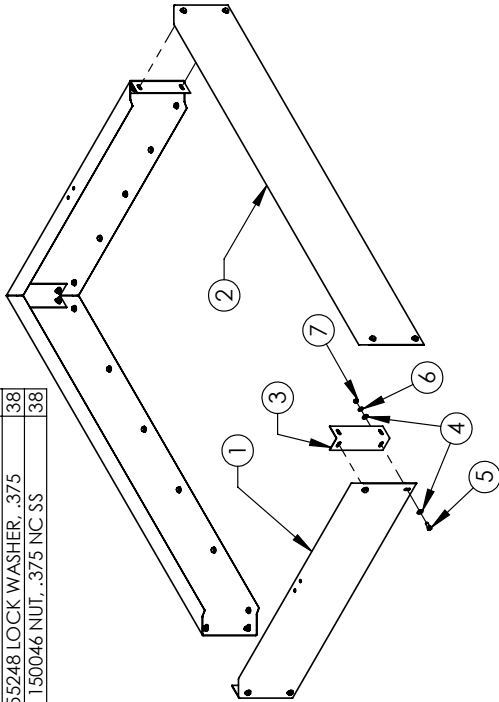

MS 4410307 100 HOPPER EXTENSION

#	PART NUMBER	Q
8	MS 4432196 MOB. 150 EXTENSION, FRONT & BACK	2
9	MS 4432194 100 & 150 SIDE EXTENSION	2
10	MS 4432195 EXTENSION BRACKET	4
11	150212 FLAT WASHER, .375 PLTD	76
12	120233 BOLT, .375 NC X 1, SS	38
13	155248 LOCK WASHER, .375	38
14	150046 NUT, .375 NC SS	38

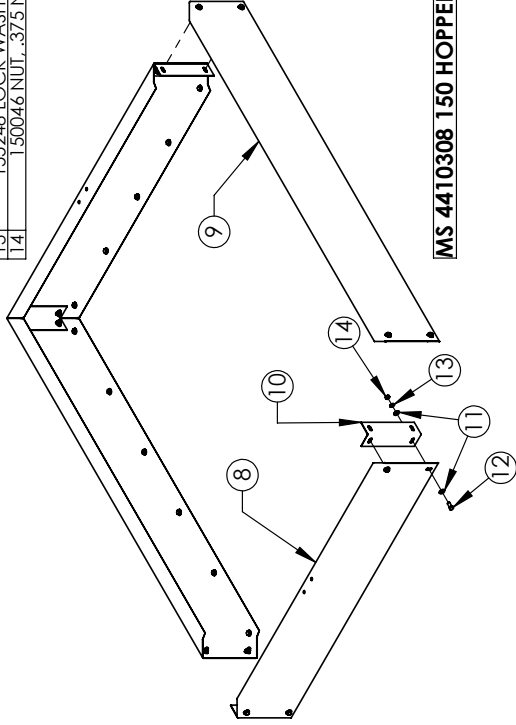

MS 4410308 150 HOPPER EXTENSION

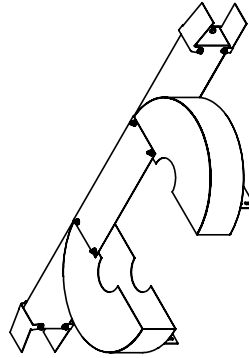

MS 4410306 SPREADER BANDER

PROPRIETARY AND CONFIDENTIAL
 THE INFORMATION CONTAINED IN THIS DRAWING IS THE SOLE PROPERTY OF DALTON AG. ANY REPRODUCTION IN PART OR AS A WHOLE WITHOUT THE WRITTEN PERMISSION OF DALTON AG IS PROHIBITED.

DRAWN BY	RICH SMOTHERS	10/29/2014
CHECKED BY		
PRINT DATE		11/13/2014
CONFIG.	Default	
COMMENTS:		



DWG: MOBILITY 100 & 150 ADD-ONS

SIZE	A	SHEET TITLE:	Sheet1	REV	A
SCALE:	1:25			SHEET 1 OF 1	

FOR PARTS, CALL 1.800.342.7498

5 4 3 2 1

PARTS ORDERING PROCEDURE

Your Dalton Ag dealer is interested in your new fertilizer application equipment and has the desire to help you get the most value from it. Through the help of this manual, you will find you can do some of the regular maintenance yourself. For parts and service, contact the Dalton Ag Dealership from which you purchased your fertilizer application equipment or your local Dalton Ag dealer.

When replacement parts are required, consult the applicable illustration and parts list to obtain the correct part name and number. When requesting a replacement part, always include the following information:

1. Complete Part Number
2. Description
3. Quantity Required
4. Machine and Model Number
5. Machine Serial Number - located on the topside of the frame near hitch
6. Provide complete name and address for where and how parts are to be shipped.

NOTE: Right and left hand parts and sides of the units are determined by standing at the rear and facing in the direction of forward travel.

EQUIPMENT MODEL: _____

EQUIPMENT SERIAL NO.: _____

DATE OF PURCHASE: _____

NAME OF DEALER: _____

DEALER'S PHONE NUMBER: _____

Thank you for your business!

NOTES

NOTES



www.daltonag.com

602 E. VAN BUREN | LENOX, IOWA 50851 | 800-342-7498