



OPERATING AND PARTS MANUAL
WNDT1000 & WNDT1500 DUAL TANK
WAGONS

2026



TABLE OF CONTENTS

TO YOU THE OWNER.....	1
LIMITED WARRANTY STATEMENT.....	2
NEW MACHINE CHECKOUT.....	3
IMPLEMENT SAFETY.....	4
PRE-SEASON CHECK.....	5
BOLT TORQUE CHART.....	6
ANHYDROUS AMMONIA SAFETY.....	7
FIRST AID.....	11
4410168, EXTENDABLE TONGUE ASSEMBLY.....	13
4410168, EXTENDABLE TONGUE ASSEMBLY.....	14
DA12 ACTUATOR INSTRUCTIONS & BLEEDING.....	15
DA12 ACTUATOR PARTS LIST.....	16
5TH WHEEL ASSEMBLY.....	17
FRONT BOLSTER ASSEMBLY.....	18
1002194, 819 8-BOLT HUB ASSEMBLY.....	19
2001113, 758 8-BOLT HUB ASSEMBLY.....	20
DT SAFETY HOOP ASSEMBLY.....	21
WNDT1000 & 1500 TANK CHANNEL ASSEMBLY.....	22
BOLT-ON STEP AND HOSE HOLDER WELDMENTS.....	23
TANK MOUNTING HARDWARE.....	24
WNDT1000SA AXLE WELDMENT AND HUB.....	25
LH AND RH TANDEM WALKERS, NON BRAKE (WNDT1000).....	26
LH AND RH TANDEM WALKERS, WITH 2-WHEEL BRAKES (WNDT1000).....	27
LH AND RH TANDEM WALKERS, WITH 4-WHEEL BRAKES (WNDT1000).....	28
LH AND RH TANDEM WALKERS, NON-BRAKE (WNDT1500).....	29
LH AND RH TANDEM WALKERS, WITH 2-WHEEL BRAKES (WNDT1500).....	30
LH AND RH TANDEM WALKERS, WITH 4-WHEEL BRAKES (WNDT1500).....	31
13" BRAKE PARTS LIST.....	32
BRAKE INSTRUCTIONS AND MAINTENANCE.....	37
WNDT BRAKE LINE PLUMBING.....	38
WNDT DECAL LAYOUT.....	39
PARTS ORDERING PROCEDURE.....	40



Disclaimer

Dalton Ag disclaims all liability for any NH₃ (Anhydrous Ammonia) plumbing installed on any NH₃ trailer. It is the end user's responsibility to consult local and state authorities for proper plumbing regulations specific to the equipment being used. Users should also follow all guidelines set forth by NH₃ product manufacturers.

Manufacturer Contact Info:

Continental NH₃

NH₃ (Anhydrous Ammonia) Products Manufacturer
1.800.537.5642
www.continentalnh3.com

Squibb Taylor

NH₃ (Anhydrous Ammonia) Products Manufacturer
1.800.345.8105
www.squibbtaylor.com

Arcosa

NH₃ Tank Manufacturer
1.888.558.8225
www.arcosatank.com

Quality Steel

NH₃ Tank Manufacturer
1.800.345.2494
www.qualitysteelcorporation.com

Raven Industries

NH₃ Precision Products
1.800.243.5435
www.ravenprecision.com

SAFETY CHAIN

Always use a safety chain between the machine and the implement.

- Install the safety chain to the implement support bracket.
- Support the center of the safety chain with a clevis installed to the implement.
- Check the adjustment of the safety chain length by driving the implement forward and turning completely to the left and right. Adjust the length of the safety chain as necessary.
- Install safety chains by criss crossing chains under tongue and secure to the draw bar cage, mounting loops or bumper frame.



TO YOU, THE OWNER

Your Dalton Ag Equipment is the most modern, up-to-date, versatile, machine available for fertilizer application. The machine is the result of many years of experience, research, development and testing of equipment for fertilizer application. It is soundly engineered and carefully built to rigid specifications. It is of rugged and simple construction, with a minimum of moving parts.

However, to obtain maximum performance from your Dalton Ag Equipment, it is necessary to follow the instructions and safety suggestions in this manual. Each section has been carefully prepared for the purpose of providing needed and valuable information to the owner and operator. Each operator of this unit should be familiar with the contents of this manual. Keep it in a safe and convenient location. THERE ARE MANY SAFETY SUGGESTIONS (CAUTION AREAS) PRINTED THROUGHOUT THIS MANUAL. CAREFULLY READ THEM ALL BEFORE OPERATING THIS UNIT.

DESIGN IMPROVEMENTS

Dalton Ag Products follows a policy of continuous products improvement. We therefore reserve the right to make design improvements, and changes in specifications and prices, without incurring obligations to make revisions or additions to equipment previously sold.

**REGISTER
WARRANTY
ONE OF
FOUR WAYS**

- Register on-line at:
www.daltonag.com
- Fax your completed warranty registration form to:
641-569-7033
- E-mail your completed warranty registration form to:
office@daltonag.com
- Mail your completed warranty registration form to:
Dalton Ag Products
P.O. Box 70
Lenox, IA 50851



LIMITED WARRANTY STATEMENT

DALTON AG PRODUCTS warrants to the original purchaser only that all products manufactured under the Dalton Ag and Mobility Brands will be free from defects in material and workmanship under normal use and service.

DALTON AG’s obligation under this warranty is limited to repairing or replacing, as it may elect, free of charge and without charge for installation, at the place of business of a dealer or distributor authorized to handle the equipment covered by this warranty or at a DALTON AG facility, any parts that prove, in DALTON AG's judgment, to be defective in material or workmanship within two (2) years after delivery to the original purchaser. DALTON AG shall not be liable for personal injuries or any special or consequential damages of any kind, either direct or indirect. This warranty is subject to acts of God, fire and existing conditions of supply and demand, production, ability or inability to deliver, or for any other valid reason beyond the reasonable control of DALTON AG. No distributor, dealer, agent or DALTON AG employee (other than DALTON's President in writing) is authorized to extend or make any other or further express or implied warranty or incur any additional obligation on DALTON AG’s behalf in connection with the sale of this product.

Customer Responsibility

Product Registration - It is a condition of this warranty that the original purchaser fill out the warranty card furnished by DALTON AG and return it to DALTON AG to be recorded in DALTON AG’s owner file. Registration may also be done on line at www.DaltonAg.com/warrantyregistration. If the original purchaser's card or electronic registration is not on file at DALTON AG’s office, the warranty period will extend only from date equipment was picked up or shipped from the DALTON AG plant.

Maintenance - It is the customer’s responsibility to maintain their equipment in accordance with the instructions provided in the Operator’s Manual. DALTON AG recommends that you keep records and receipts as the customer may be required to verify the maintenance instructions have been followed.

Operation – It is the customer’s responsibility to operate the equipment only for the purpose for which it was designed and in accordance with all safety and operational recommendations contained in the Operator's Manual. If a defect in materials or workmanship occurs, it is the customer’s responsibility to cease operating the equipment until authorized repairs are made.

Damage incurred from continued operation after a defect is discovered may not be covered by this warranty.

What this Warranty Covers

This warranty covers failures caused by defects in materials or workmanship only.

This Warranty does not cover failures caused by:

- Improper operation
- Natural calamities
- Unauthorized modifications
- Unauthorized repairs
- Use of Non DALTON AG parts
- Neglected maintenance
- Usage contrary to the intended purpose of the product

This Warranty does not cover replacement of Wear or Maintenance Items including, but not limited to:

- Lubricants
- Filters
- Hoses
- Tires
- Disks
- Chains
- Idlers
- Blades
- Belts
- Bearings

This Warranty does not cover:

- Pickup and delivery of the equipment
- Service Calls or Travel Time to and from sites
- Rental of replacement equipment during repair period
- Products that have been declared a total loss and subsequently salvaged
- Overtime labor charges

Parts Warranty

DALTON AG warrants its replacement parts against defects in materials or workmanship for a period of 90 days or the remainder of the product warranty, whichever is longer under the terms set out above. Remedy for defective replacement parts for units that are beyond the original product warranty, will be limited to replacement of the failed part.

DaltonAg.com

602 E. Van Buren Lenox, Iowa 50851

PHONE: 800.342.7498

FAX: 641.569.7033

NEW MACHINE CHECKOUT

1. All hardware properly tightened.
2. Lubrication of grease fittings.
3. Wheel bolts tightened to proper specs.

MAINTENANCE

1. Visually inspect machine daily.
2. Repair or replace any worn or damaged parts.

LUBRICATION SCHEDULE

Careful observance of the following lubrication schedule is the best preventative maintenance program for your Dalton Ag Equipment. We recommend that you establish a firm program to insure lubrication in strict compliance with the following schedule. Use only good grade pressure gun type grease unless otherwise specified.

Daily Lubrication

Hinge points

Weekly Lubrication

Wheel bearings

Annual Lubrication

Check all bearings - repack or replace as needed

IMPLEMENT SAFETY

In addition to design and configuration of equipment, safety and accident prevention are dependent upon the awareness, concern, and proper training of personnel involved in the operation, transport, maintenance, and storage of equipment. Failing to follow these safety messages can result in machine damage, personal injury, and/or death.

- Before operating your DALTON AG equipment, thoroughly read and understand your operator's manual. If you do not understand any portion of the operator's manual, contact your local Dalton Ag dealer immediately for clarification.
- Furnish this manual to a new operator.
- Tow with tractor only. Never transport equipment in excess of 20 MPH. Maintain a safe speed.
- Use a Slow-Moving-Vehicle (SMV) emblem when transporting.
- Be sure safety decals are readable. All safety related decals must be replaced if the equipment is painted or the decals are otherwise rendered unreadable.
- Install transport link before transporting.
- Always check for overhead obstacles in transporting equipment.
- Never permit riders on the equipment or tractor.
- Proceed slowly on rough or slippery roadways, on side hills, and around curves to avoid tipping.
- Reduce speed when approaching ditches and corners. Do not make sharp turns with brakes.
- Machinery should be operated only by persons familiar to the tractor, equipment, and the safety related items.
- Do not stand on, or straddle tongue when unhitching.
- Do not modify or permit anyone to modify this equipment and any of its components without first consulting your Dalton Ag dealer.
- Do not lubricate, adjust, or repair when equipment is in motion.
- Use only approved replacement parts.
- Always check torque on wheel bolts before transporting.

PRE-SEASON CHECK

1. Carefully review the safety suggestions in this manual.
2. Check all bolts for proper tightness. When the implement is new, check after one hour and every few hours of operation.
3. Check tires for proper inflation. All tires should be inflated equally to avoid side draft.
4. Check the wheel lug bolts daily, keep wheel bolts tight.
5. Grease all fittings.
6. Inspect, repack, or replace (if necessary) wheel bearings and seals.





OFF-SEASON STORAGE

Following these suggestions will extend service life and satisfaction:

1. A little time and effort spent cleaning your machine before storing will repay in longer service, easier operation and higher resale value.
2. Inspect for worn or damaged parts. Replace, if required, and avoid delays the next season.
3. Repaint all areas where the original paint is worn off.
4. Lubricate your implement.
5. Store the unit inside a shed to protect from weather and on a level area.
6. Raise tires off ground or remove and store in cool dry location out of sunlight.

IMPORTANT : Over tightening hardware can be as damaging as under tightening. Tightening beyond recommended torque will reduce the fastener's shock load capacity.

BOLT TORQUE CHART

SIZE	 SAE GRADE 2		 SAE GRADE 5		 SAE GRADE 8		 L9
	ASSEMBLY TORQUE		ASSEMBLY TORQUE		ASSEMBLY TORQUE		ASSEMBLY TORQUE
	DRY	LUBRICATED	DRY	LUBRICATED	DRY	LUBRICATED	LUBRICATED
1/4-20	66*	49*	8	75*	12	9	11
1/4-28	76*	56*	10	86*	14	10	13
5/16-18	11	8	17	13	20	18	21
5/16-24	12	9	19	14	25	20	23
3/8-16	20	15	30	23	45	30	33
3/8-24	23	17	35	25	50	35	38
7/16-14	30	24	50	35	70	55	60
7/16-20	35	25	55	40	80	60	65
1/2-13	50	35	75	55	110	80	95
1/2-20	55	40	90	65	120	90	105
9/16-12	65	50	110	80	150	110	140
9/16-18	75	55	120	90	170	130	150
5/8-11	90	70	150	110	220	170	185
5/8-18	100	80	180	130	240	180	205
3/4-10	160	120	260	200	380	280	290
3/4-16	180	140	300	220	420	320	355
7/8-9	190	140	400	300	600	460	505
7/8-14	210	155	440	320	660	500	585
1-8	220	160	580	440	900	680	775
1-14	240	170	640	480	1000	740	900
1 1/8-7	300	220	800	600	1280	960	1150
1 1/8-12	340	260	880	660	1440	1080	1325
1 1/4-7	420	320	1120	840	1820	1360	1600
1 1/4-12	460	360	1240	920	2000	1500	1750
1 3/8-6	560	420	1460	1100	2380	1780	---
1 3/8-12	640	460	1680	1260	2720	2040	---
1 1/2-6	740	560	1940	1460	3160	2360	3250
1 1/2-12	840	620	2200	1640	3560	2660	3650

**ITEMS WITH * = INCH POUNDS
ALL OTHERS = FOOT POUNDS**

WARNING: Never work around any raised implement while in the raised position without using safety lockups.

ANHYDROUS AMMONIA SAFETY

(Source: Pennsylvania State University. Agricultural Safety and Health)

Anhydrous ammonia (NH₃) is a nitrogen crop fertilizer that can cause severe chemical burns; frostbite to the eyes, skin, and respiratory tract; and death. It is important for all individuals working with this type of fertilizer to understand the potential risks, necessary safety precautions, and proper response in the event of accidental contact.

Anhydrous ammonia is a hygroscopic compound, meaning that it takes up water from the nearest source, which can include the human body—especially the eyes, lungs, and skin because of their high moisture content. Anhydrous ammonia is caustic, corrosive, and damaging to tissue high in moisture content when it contacts the human body. Anhydrous ammonia inhalation incidents are typically severe because the victim's throat can swell shut, causing suffocation. When vapors or liquid come in contact with a person's eyes, blindness may occur.

Typically, anhydrous ammonia is stored under pressure, but it vaporizes to a colorless gas. It has a unique odor that can be detected at a low concentration of 5 ppm. The concentration in fertilizer is approximately 1,000,000 ppm, but even brief exposure to a concentration of 2,500 to 6,500 ppm can result in death.

Anhydrous ammonia is transported under pressure as a liquid, so all equipment used for transport must be designed for use under high pressure to avoid ruptures or breaks. Incidents can occur when anhydrous ammonia escapes from transfer hoses or valves, equipment malfunctions and sprays anhydrous ammonia in multiple directions, hoses pull apart during transportation or application, and so on.

PPE and Supplies

It is essential that all workers who use anhydrous ammonia wear the appropriate personal protective equipment (PPE), be equipped with necessary response supplies, and know how to respond in an emergency. PPE should include ventless goggles or a full-face shield, rubber gloves with long cuffs that can be rolled to catch drips, and a long-sleeved shirt. Non-rubber gloves made of ammonia-proof material are acceptable. Because contact lenses can trap the gas and become fused to the eye, it is recommended that individuals not wear contact lenses while working with anhydrous ammonia.

In the event of an exposure emergency, the most important resource is an ample supply of clean water to begin flushing the eyes and skin. If you use a vehicle to transport anhydrous ammonia, you must carry a 5 gal. container of clean water. Each person working with anhydrous ammonia should carry a 6 to 8 fl. oz. squeeze bottle of water at all times for rapid response to an emergency.

Basic First Aid for Anhydrous Ammonia Exposure

The first-response treatment for anhydrous ammonia exposure is to flush the exposed area (skin, nose, throat, eyes, and so on) with clean water for a minimum of 15 minutes.

- Flush the exposed area immediately to decrease injury caused by the anhydrous ammonia coming in contact with skin or clothes. Although clean water is the ideal resource for flushing exposed areas of the body, if you do not have water available, other nontoxic liquids, such as cold coffee or orange juice, can be used.
- Remove contaminated clothing unless the clothing is frozen to the victim's skin.
- Seek medical attention immediately and inform medical staff of the exposure to anhydrous ammonia so that they will not treat the wounds with oils or ointments that can intensify the damage.

If you find a person who is in a continuous stream of anhydrous ammonia, contact your local emergency service responders or 911. Inform the emergency medical responders about the type of incident so they can bring the proper equipment to the scene. A self-contained breathing apparatus (SCBA) and protective clothing are necessary to remove a person from a continuous stream. Rescue workers will contact a hazardous materials (HAZMAT) disposal team if HAZMAT services are needed at the scene.

Note that these guidelines are not comprehensive, and all individuals working with anhydrous ammonia should receive training in the proper response to exposure emergencies.

Storage and Transportation

Anhydrous ammonia is a strong alkali that, when dissolved in water, readily reacts with copper, zinc, brass, and other alloys. Therefore, the only types of containers, fittings, and piping that should come in contact with anhydrous ammonia should be non-galvanized steel or iron. Do not store other materials, such as propane or liquefied petroleum gas, in a tank that has been used to store anhydrous ammonia.

When filling your anhydrous ammonia tank, do not fill it more than 85% full, and always disconnect the fill hose before moving the tank. Remember to bleed pressurized anhydrous ammonia from the hose before connecting or disconnecting the hose.

When transporting anhydrous ammonia, be sure to adhere to the following precautions and safety rules:

- **Running Gear:** Regularly inspect the wagon's frame tongue, reach poles, anchor devices, wheel bearings, knuckles, ball joints, and pins for structural damage and wear and make necessary repairs and adjustments.
- **Tires:** Check tires for proper inflation, bald spots, and signs of wear and ensure that lug nuts are tight.
- **Hoses and Valves:** Inspect and replace hoses and valves as needed.
 - o The hydrostatic relief valve should be replaced every five years.
 - o The transfer hose should be replaced five years from the date of manufacture.

- **Lubrication:** Annually lubricate the wagon's knuckle, wheels, tongues, and so on.
- **Towing Vehicle:** To increase the driver's ability to control the towing vehicle, ensure that the towing vehicle weighs at least as much as the tank.
 - o A tractor can tow two tanks, but a truck can tow only one tank at a time.
- **Speed Limit:** When towing an anhydrous ammonia tank, observe a speed limit of 25 mph.
- **Hitch Pin:** Use a hitch pin with a safety chain when towing a tank wagon.
- **Warning Lights:** Ensure that the tank is equipped with a seven-terminal breakaway connector plug to properly operate turn signals, flashing warning lights, and a red brake light.
- **Safety Signage:** If operating on a highway, outfit the tank with all required safety markings, including a slow-moving vehicle (SMV) sign.
 - o The words *Anhydrous Ammonia* must appear on both sides of the tank and on the rear of the tank in letters 4 in. high. The words should be in contrast to the tank so that they can be read easily.
 - o *Inhalation Hazard* must appear on both sides of the tank in letters 3 in. high.
 - o A Department of Transportation (DOT) placard number 1005 for nonflammable gas should be placed on the front, back, and sides of the tank.

Additional Safety Recommendations

- Paint the tank with reflective white paint to decrease excessive pressure buildup that can occur when the tank is heated from direct sunlight.
- Do not use dented or damaged tanks until they have been checked by an authorized inspector and necessary repairs are completed.
- Allow only certified welders to perform welding on the tank.
- Regulations and codes regarding towing of anhydrous ammonia and signage may vary, so be familiar with and obey the regulations in your state.

Summarized by:

Linda M. Fetzer, Pennsylvania State University – lmf8@psu.edu

Reviews:

LaMar Grafft, University of Iowa – lamar-grafft@uiowa.edu

Dennis J. Murphy, Pennsylvania State University – djm13@psu.edu

J. Samuel Steel, Pennsylvania State University – jss13@psu.edu

Aaron M. Yoder, University of Nebraska Medical Center - aaron.yoder@unmc.edu

Use the following format to cite this article:

Anhydrous ammonia safety. (2012) Farm and Ranch eXtension in Safety and Health (FReSH) Community of Practice. Retrieved from <http://www.extension.org/pages/63196/anhydrous-ammonia-safety>.

Sources

Schwab, C., Hanna, M., & Miller, L. (2008) Anhydrous ammonia safety: Play it safe with anhydrous ammonia. Iowa State University Extension and Outreach. Retrieved from <https://store.extension.iastate.edu/ItemDetail.aspx?ProductID=4989>.

Training module: Safe handling of anhydrous ammonia (NH₃). (2002) Ohio State University Extension. Retrieved from <http://nasdonline.org/1731/d001719/safe-handling-of-anhydrous-ammonia-nh....>

Training module: Towing anhydrous ammonia tanks. (2002) Ohio State University Extension Agricultural Tailgate Safety Training. Retrieved from <http://nasdonline.org/1794/d001750/towing-anhydrous-ammonia-tanks.html>

FIRST AID

Decontaminate the victim as quickly as possible. Start with the eyes. The whole body, or exposed area, must be flushed with generous amounts of water; this includes the hair, ears, under the chin, and armpits. Water sources such as showers, hoses, eye wash stations, or stock tanks are acceptable [29 CFR 1910.151(c)]

Ensure trained personnel and adequate first aid supplies are readily available [29 CFR 1910.151(b)]



Eyewash Station

Contact with the Eyes

Even if only a small amount of ammonia enters the eyes, irrigate the eyes with an abundance of water for a minimum of 15 minutes. Continually and thoroughly flush the entire eye surface and the inner lining of the eyelids. Eyes affected by ammonia close involuntarily, so the eyelids must be held open so that water can flush the entire eye surface, as well as the inner lining of the eyelid.

If there is no physician available, continue irrigation for an additional 15 minutes.

Do not wear contact lenses when handling anhydrous ammonia. If ammonia gets in the eyes, the ammonia will get trapped under the lenses causing even more damage. They may also prevent immediate flushing of the eye surface.

Serious eye injury should be treated by an ophthalmologist, but in an emergency, wash with large quantities of water for 15 minutes or more as quickly as possible. In fact, the only real hope for preventing permanent eye injury lies in quick and generous washing.

One suggestion for those likely to be exposed is to carry a small, eight-ounce squeezable squirt bottle filled with water, which can be used to get excess ammonia out of the eyes until a larger water supply can be reached. This small amount of water is not sufficient to remove all the ammonia. It is essential that the eyes be irrigated for a minimum of 15 minutes as soon as possible.



Squirt Bottle

Another emergency method is to duck the head in water and rapidly blink and move or rotate the eyes about.

Contact with the Skin

It is essential that any ammonia spilled on the worker be removed immediately and that the worker be moved to an uncontaminated area quickly.

Clothes that have been saturated by liquid ammonia may freeze to the skin. In any case, the victim, still clothed, should get immediately under a shower, if available, or jump into a stock tank, pond, or into any other source of water. Time is important! Remove clothes only after they are thawed and they can be freely removed from frozen areas. If the clothing is removed incorrectly, whole sections of skin can be torn off.

No salves, creams, ointments, or jellies should be applied to the skin during a 24-hour period following the injury since this will prevent natural elimination of the ammonia from the skin. After the 24 hour period, the medical treatment is the same for thermal burns. A physician should view any second- or third-degree freeze burns of the skin.

Taken Internally: This is what you should do if ammonia is ingested:

- Call a physician.
- If conscious, have the victim drink large amounts of water.
- Do not induce vomiting if the victim is in shock, in extreme pain, or is unconscious.
- If vomiting begins, place the victims face down with head lower than hips. This prevents vomit from entering the lungs and prevents severe injury.

Inhalation

In all inhalation exposures, severe or minimal:

- Take the exposed workers at once to a clean, uncontaminated area.
- Watch workers exposed to low concentrations for a short period of time. They will usually require no treatment and can be released.
- For severe exposure to higher concentrations:
 - Call a physician.
 - Administer oxygen by an individual who is trained and authorized to do so by a physician. This will help relieve pain and symptoms of lack of oxygen.
 - Begin artificial respiration immediately if the patient is not breathing.
 - Keep victim warm (but not hot) and rested until transported to the hospital.

Summary: In any accident involving contact with ammonia with the eyes or skin:

- Immediately flush the affected area with large quantities of clean water.
- Place the injured person into a container of clean water or under an emergency shower.
- Provide the injured worker with first aid treatment and call a physician at once in the case of extreme exposure. Give the physician a complete account of the incident.
- Seconds count, wash the ammonia away with water immediately.

Information from U.S. Department of Labor - OSHA

https://www.osha.gov/SLTC/etools/ammonia_refrigeration/emergency/index.html#firstaid

4410168 EXTENDABLE TONGUE ASSEMBLY (LESS BRAKE ACTUATOR)

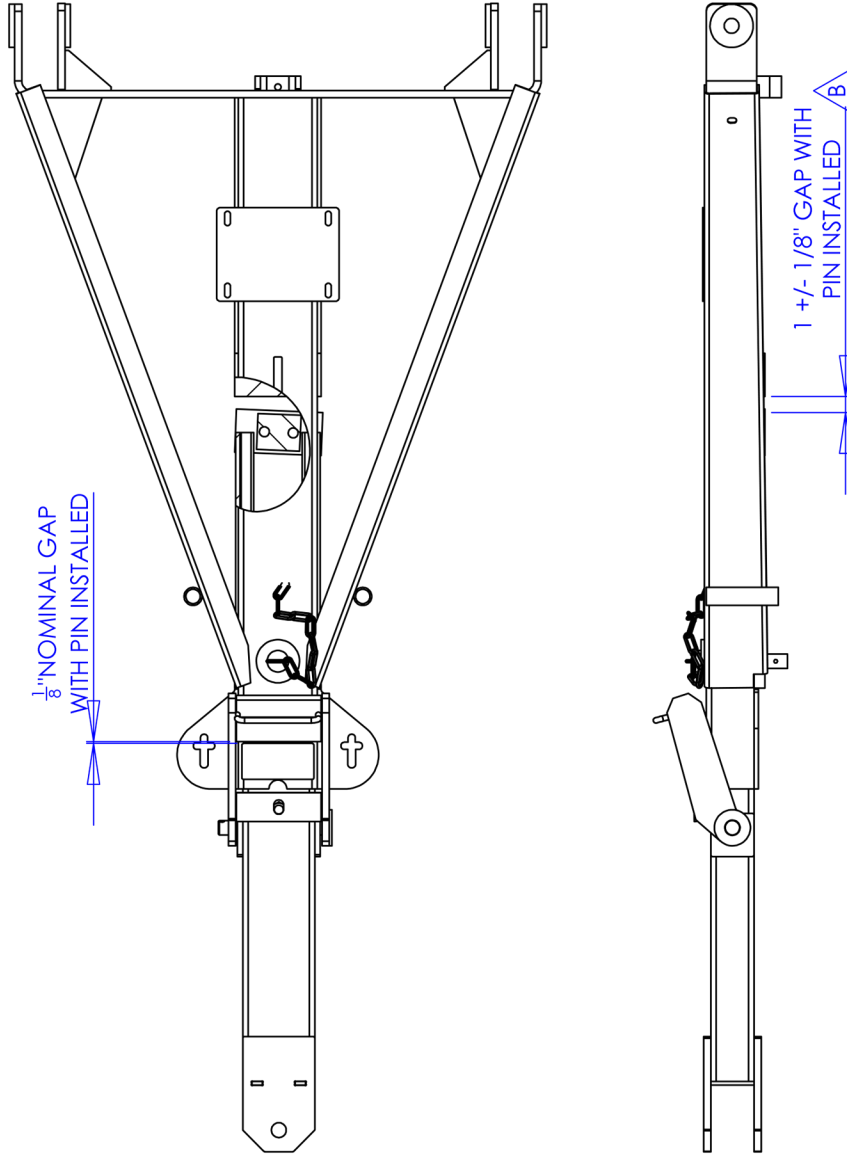

DRAWN BY	RICH SMOTHERS	8/25/2010	 DALTON USA A L L I E S I E S P R O P E R T Y S 602 E. VAN BUREN ST., LENOX, IA 50851	
CHECKED BY				
PRINT DATE	6/3/2024			
CONFIG.	Default			
COMMENTS:	DWG: DT 4410168 EXTENDABLE TONGUE ASSEMBLY, LESS BRAKE ACTUATOR SIZE SHEET TITLE: BRAKE TONGUE REV A			
PROPRIETARY AND CONFIDENTIAL THE INFORMATION CONTAINED IN THIS DRAWING IS THE SOLE PROPERTY OF DALTON AG. ANY REPRODUCTION IN PART OR AS A WHOLE WITHOUT THE WRITTEN PERMISSION OF DALTON AG IS PROHIBITED.				SCALE: 1:12 SHEET 1 OF 2
FOR PARTS, CALL 1.800.342.7498				1 2 3 4 5

#	PART NUMBER	QTY.
1	DT 4420260 BRAKE TONGUE FRAME	1
2	DT 4420264 BRAKE TONGUE INNER SLIDE	1
3	DT 4420265 BRAKE TONGUE KEEPER BLOCK	1
4	DT 4420263 BRAKE TONGUE, LATCH	1
5	150223 FLAT WASHER, .625 STD PLN	2
6	150222 LOCK WASHER, .625, PLTD	2
7	150220 FLAT WASHER, .5 PLTD	2
8	150022 NUT, .375, LOCKING, PLTD	4
9	4440848 COTTER PIN, .3125 x 3	1
10	4420261 LOCK-OUT PIN WELDMENT	1
11	610500 SAFETY CHAIN, PAIR	1
12	4410188 TONGUE SPRING ASSEMBLY	1
13	4420262 PIN, 1 X 7.25, HEADED	1
14	152409 BOLT, .625 x 2.5 NC, G8	1
15	152206 BOLT, .5 x 1.5 NC, G5, PLTD	2
16	152429 BOLT, 1 x 5 NC, G5, PLTD	2
17	152407 BOLT, .625 x 2.5 NF, G8	2
18	150060 LOCKNUT, .5 NC, PLTD	2
19	150061 NUT, 1 NC, CENTERLOCK, PLTD	2
20	140148 SPRING	1

NOT INCLUDED IN ASSEMBLY

640684 HOSE, BRAKE, 2-1/2" x 20"
07686 BRAKE ACTUATOR

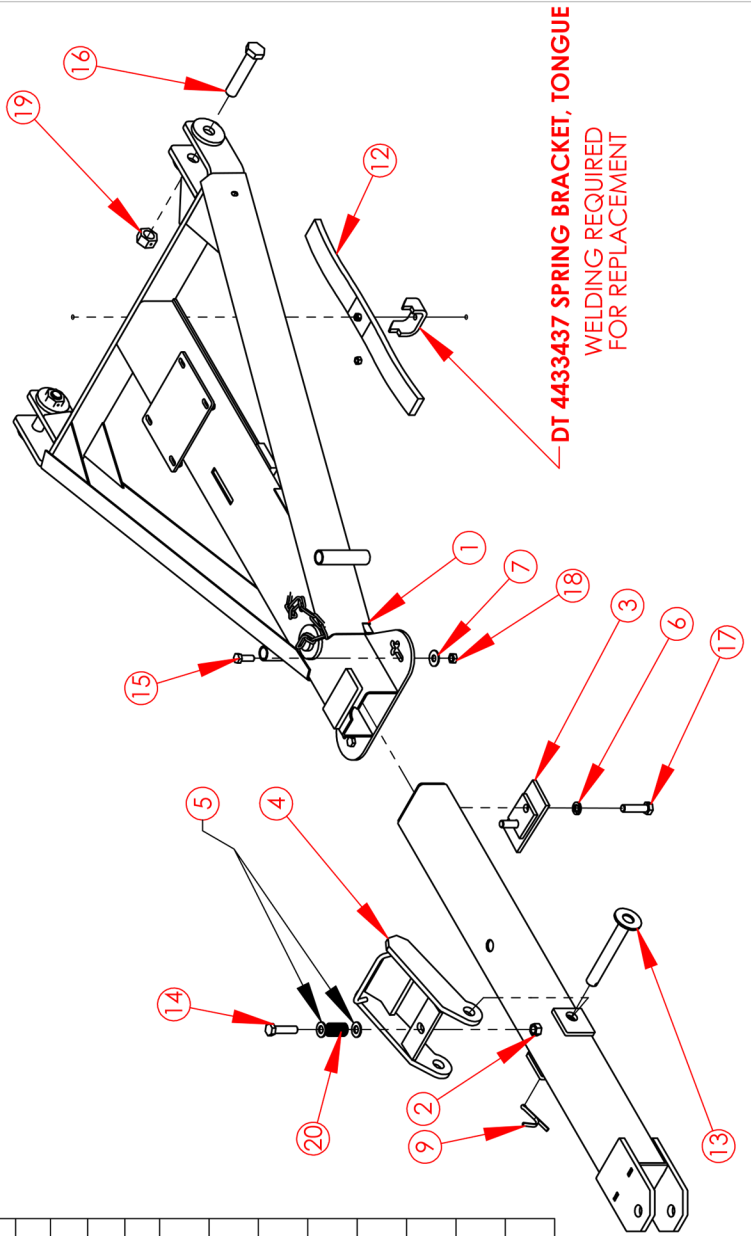
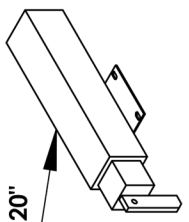

DT 4433437 SPRING BRACKET, TONGUE
WELDING REQUIRED FOR REPLACEMENT

DRAWN BY	DAVID BUCHANAN	8/25/2010
CHECKED BY		
PRINT DATE	6/3/2024	
CONFIG.	W HARDWARE	



DWG: DT 4410168 EXTENDABLE TONGUE ASSEMBLY, LESS BRAKE ACTUATOR

SIZE	A	SHEET TITLE:	EXPLODED	REV	A
SCALE:	1:15			SHEET 2 OF 2	

PROPRIETARY AND CONFIDENTIAL
THE INFORMATION CONTAINED IN THIS DRAWING IS THE SOLE PROPERTY OF DALTON AG. ANY REPRODUCTION IN PART OR AS A WHOLE WITHOUT THE WRITTEN PERMISSION OF DALTON AG IS PROHIBITED.

FOR PARTS, CALL 1.800.342.7498

DA12 ACTUATOR INSTRUCTIONS & BLEEDING

1. When installing the DA12 Actuator, make sure the shock (#4) and slider tube (#1) are fully extended or that there is 1-1/4" movement. Bolt to mounting plate, using slots for adjustment. It is important that the blocks on the end of slider tube (#1) are tight against the blocks welded to tongue of running gear and have 1-1/4" of movement from outer diameter of pin (#2) to front of outer case (#6).
2. Fill the master cylinder with DOT 3 or 4 brake fluid. A pressure type brake bleeder may be used. If one is not available, you can bleed the system manually as follows.
3. After the master cylinder has been filled, remove the flat spring (#9) behind the emergency lever (#15). Pull forward on the lever to pump the master cylinder. Use short strokes until bubbling stops in the master cylinder.

Install bleeder hose on the bleeder valve on the first wheel with other end of the hose in a glass container partially filled with the brake fluid. Loosen the bleeder valve one turn and pump the master cylinder until the air bubbles stop coming out of the hose in the glass container, then close the bleeder valve and repeat the process with the other wheel. *Watch the fluid level in the master cylinder and refill so level does not fall below 1/2 full.*

4. After bleeding is completed, refill the master cylinder and put the filler cap on securely. Replace the flat spring behind the emergency lever.

To test the brakes, use a wrench or vise grip and clamp onto the top of the emergency lever to lengthen it. Take hold one foot above the lever pivot point and pull forward with about 100 to 150 lbs pull. Have another person try to rotate the wheels in forward rotation. You should not be able to move them. If you can, set each wheels brake adjustment up 2 to 3 notches.

5. If the emergency brake lever is applied, release the lever by pulling it forward and, with a screwdriver, lift up the front of the flat spring until it releases the lever. Many times these parts are damaged when this happens. An inspection of the lever, flat spring, and chain with S-hooks is required and any damaged parts must be replaced.

Step one: In order to replace the emergency lever, you must remove the master cylinder and the push rod. **(Be careful - Do not get dirt into the master cylinder).**

Step two: Remove the flat spring. Take the S-hook off the lever. Take the lever out from the inside.

Step three: Install the new lever from the inside and up through the slot. Replace the new flat spring. Replace the push rod, master cylinder and new gasket.

Step four: Take the new chain and fasten the S-hook to the lever by squeezing the hook shut with pliers. Check the master cylinder to make sure it is full and if needed, fill with DOT 3 or 4 brake fluid. Rebleed system following steps 2 thru 4.

DA12 ACTUATOR

REV.	ECN #	DATE	DTM
A	3808	5/20/2008	BVDP
B	3905	9/22/2008	BVDP

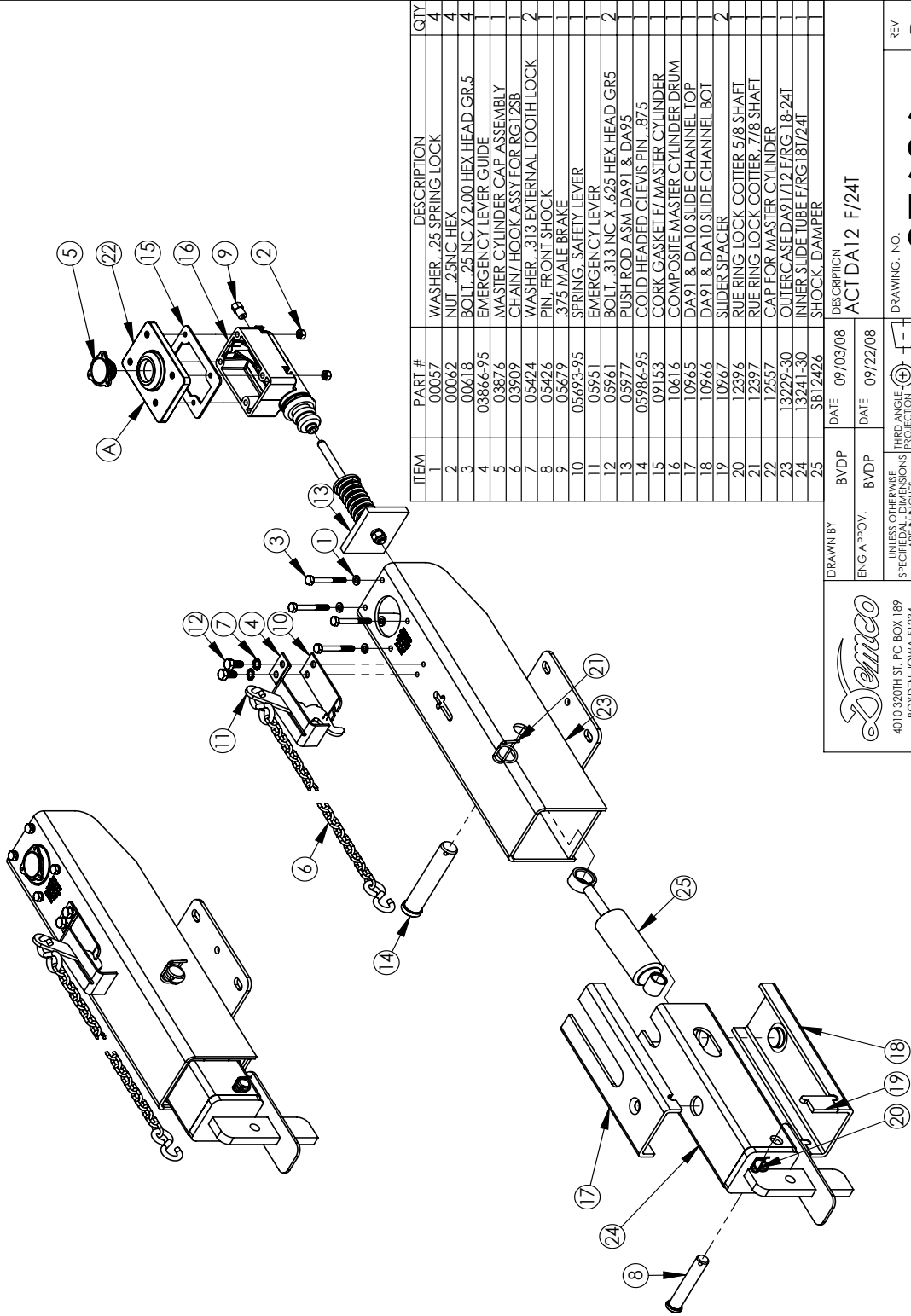

ITEM	PART #	DESCRIPTION	QTY
1	00057	WASHER, .25 SPRING LOCK	4
2	00062	NUT, .25NC HEX	4
3	00618	BOLT, .25 NC X 2.00 HEX HEAD GR5	4
4	03866-95	EMERGENCY LEVER GUIDE	1
5	03876	MASTER CYLINDER CAP ASSEMBLY	1
6	03909	CHAIN/HOOK ASSY FOR RG12SB	1
7	05424	WASHER, 3/13 EXTERNAL TOOTH LOCK	2
8	05426	PIN, FRONT SHOCK	1
9	05679	.375 MALE BRAKE	1
10	05693-95	SPRING, SAFETY LEVER	1
11	05951	EMERGENCY LEVER	1
12	05961	BOLT, .313 NC X .625 HEX HEAD GR5	2
13	05977	PUSH ROD ASM DA91 & DA95	1
14	05986-95	COLD HEADED CLEVIS PIN, .875	1
15	09153	CORK GASKET FZ MASTER CYLINDER	1
16	10616	COMPOSITE MASTER CYLINDER DRUM	1
17	10965	DA91 & DA10 SLIDE CHANNEL TOP	1
18	10966	DA91 & DA10 SLIDE CHANNEL BOT	1
19	10967	SLIDER SPACER	2
20	12396	RUE RING LOCK COITER, 5/8 SHAFT	1
21	12397	RUE RING LOCK COITER, 7/8 SHAFT	1
22	12557	CAP FOR MASTER CYLINDER	1
23	13229-30	OUTER CASE DA91/12 F/RG 18-24T	1
24	13241-30	INNER SLIDE TUBE F/RG 18/24T	1
25	SB12426	SHOCK DAMPER	1

DRAWN BY		BVDP	DATE	09/03/08
ENG APPROV.		BVDP	DATE	09/22/08
UNLESS OTHERWISE SPECIFIED DIMENSIONS ARE IN INCHES		THIRD ANGLE PROJECTION		
TOLERANCES		MIN. MACHINE SURFACE 250		
.X = ±.060		BREAK ALL SHARP EDGES		
.XX = ±.030		BEND AND DRAFT $\frac{1}{4}$ °		
.XXX = ±.010				
 4010 320TH ST. PO BOX 189 BOYDEN, IOWA 51234 THE DRAWING AND ALL INFORMATION THEREON ARE THE PROPERTY OF DEMCO		DESCRIPTION ACT DA12 F/24T		
		DRAWING NO.		07686
		REV		B
		SCALE: 1:7		SHEET 1 OF 1

5TH WHEEL ASSEMBLY

#	PART NUMBER	QTY.
1	4410170 FRONT BOLSTER ASSEMBLY w 8 BOLT HUBS	1
2	4420267 5TH WHEEL WELDMENT W KING PIN	1
3	DT 4420268-1.125 BOLSTER BRACE, WELDMENT	1
4	4420269 PIN WELD, BOLSTER BRACE	1
5	152220 BOLT .5 NC x 4, G8	1
6	150008 NUT, .5 NC, PLTD	1
7	DT 4431077 ROCKER PIN, 2.5 INCH ROUND	1
8	4431071 LOCK COLLAR, BOLSTER BRACE	1
9	640038 ROLL PIN	1
10	DT 4440864 5TH WHEEL PIN	1

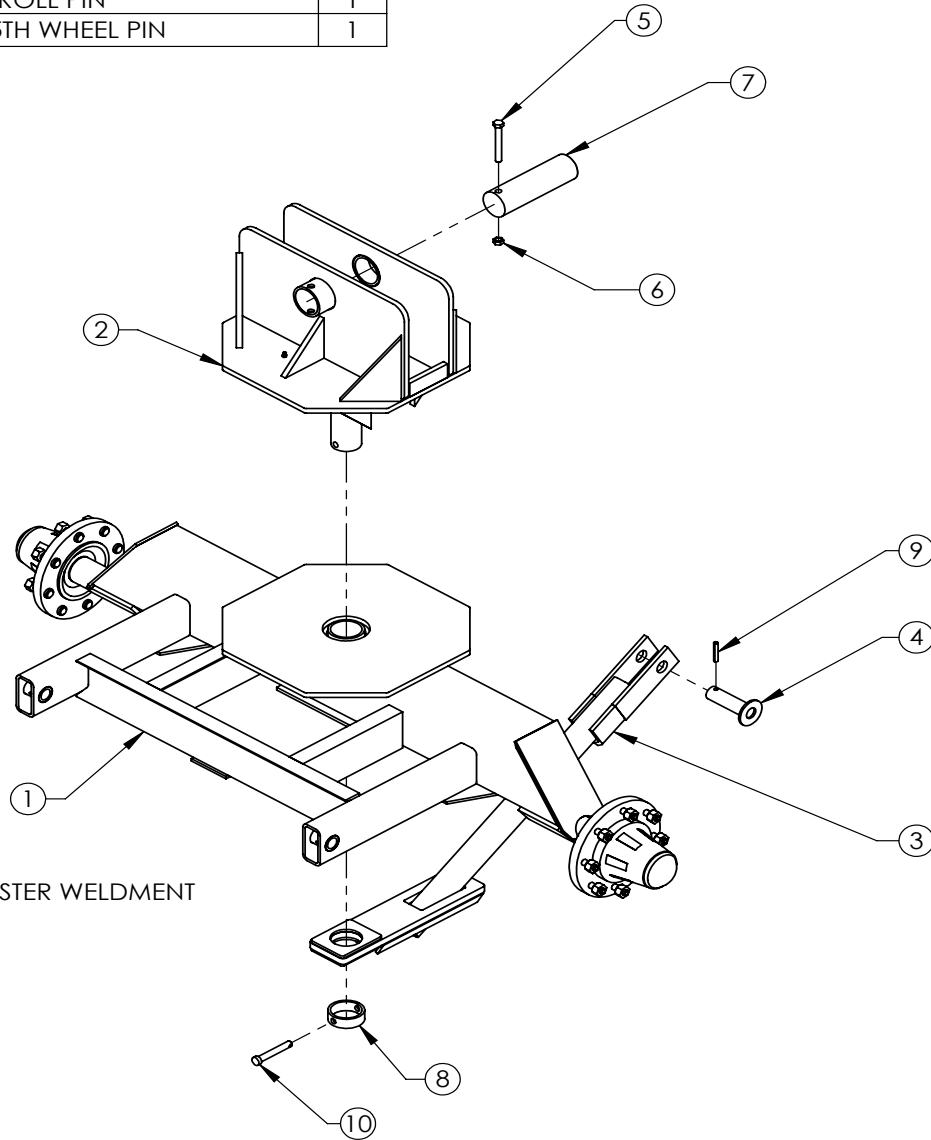

DT 4420266 FRONT BOLSTER WELDMENT
(LESS HUBS)

DRAWN BY	RICH SMOTHERS	12/3/2013
CHECKED BY		
PRINT DATE	6/16/2016	
CONFIG.	Default	



PROPRIETARY AND CONFIDENTIAL
THE INFORMATION CONTAINED IN THIS DRAWING IS THE SOLE PROPERTY OF DALTON AG. ANY REPRODUCTION IN PART OR AS A WHOLE WITHOUT THE WRITTEN PERMISSION OF DALTON AG IS PROHIBITED.

COMMENTS:

DWG: 5TH WHEEL ASSEMBLY

SIZE	SHEET TITLE:	B.O.M.	REV
A			A

FOR PARTS, CALL 1.800.342.7498

SCALE: 1:15 SHEET 1 OF 1

FRONT BOLSTER ASSEMBLY WITH 8-BOLT HUBS

FRONT BOLSTER ASSEMBLY w 8 BOLT HUBS

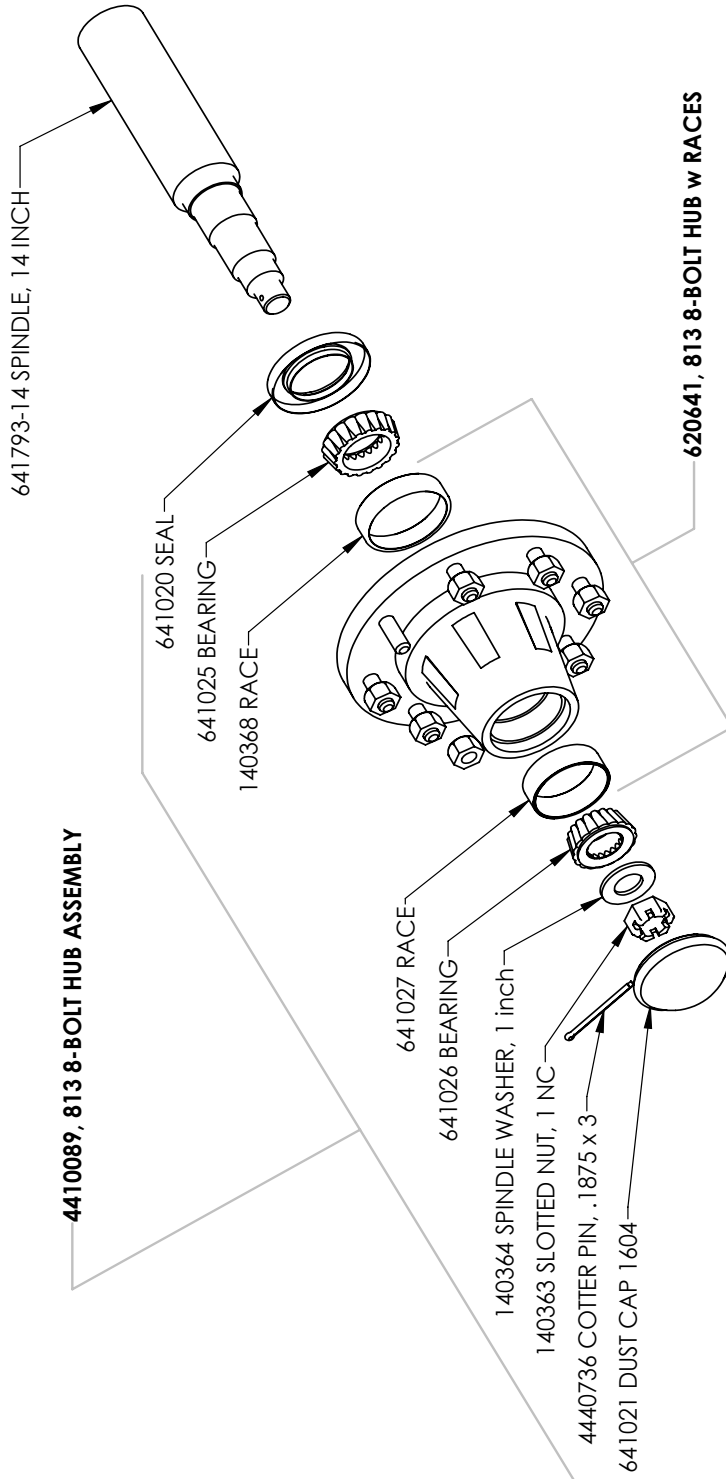

DRAWN BY RICH SMOTHERS	11/26/2013	DALTON 602 E. VAN BUREN ST., LENOX, IA 50851	DWG: FRONT BOLSTER ASSEMBLY w 8 BOLT HUBS
CHECKED BY	5/7/2015	SIZE A	SHEET TITLE: Sheet1
PRINT DATE	EXPLODED VIEW	REV A	SCALE: 1:6
COMMENTS: PROPRIETARY AND CONFIDENTIAL THE INFORMATION CONTAINED IN THIS DRAWING IS THE SOLE PROPERTY OF DALTON A.G. ANY REPRODUCTION IN PART OR AS A WHOLE WITHOUT THE WRITTEN PERMISSION OF DALTON A.G IS PROHIBITED.		SHEET 1 OF 1	1
FOR PARTS, CALL 1.800.342.7498		3	2
5	4	1	1

1002194, 819 8-BOLT HUB ASSEMBLY

1002194, 819 8-BOLT HUB ASSEMBLY, COMPLETE

4450041 HUB REBUILD KIT
-INCLUDES BEARINGS, RACES, AND SEALS

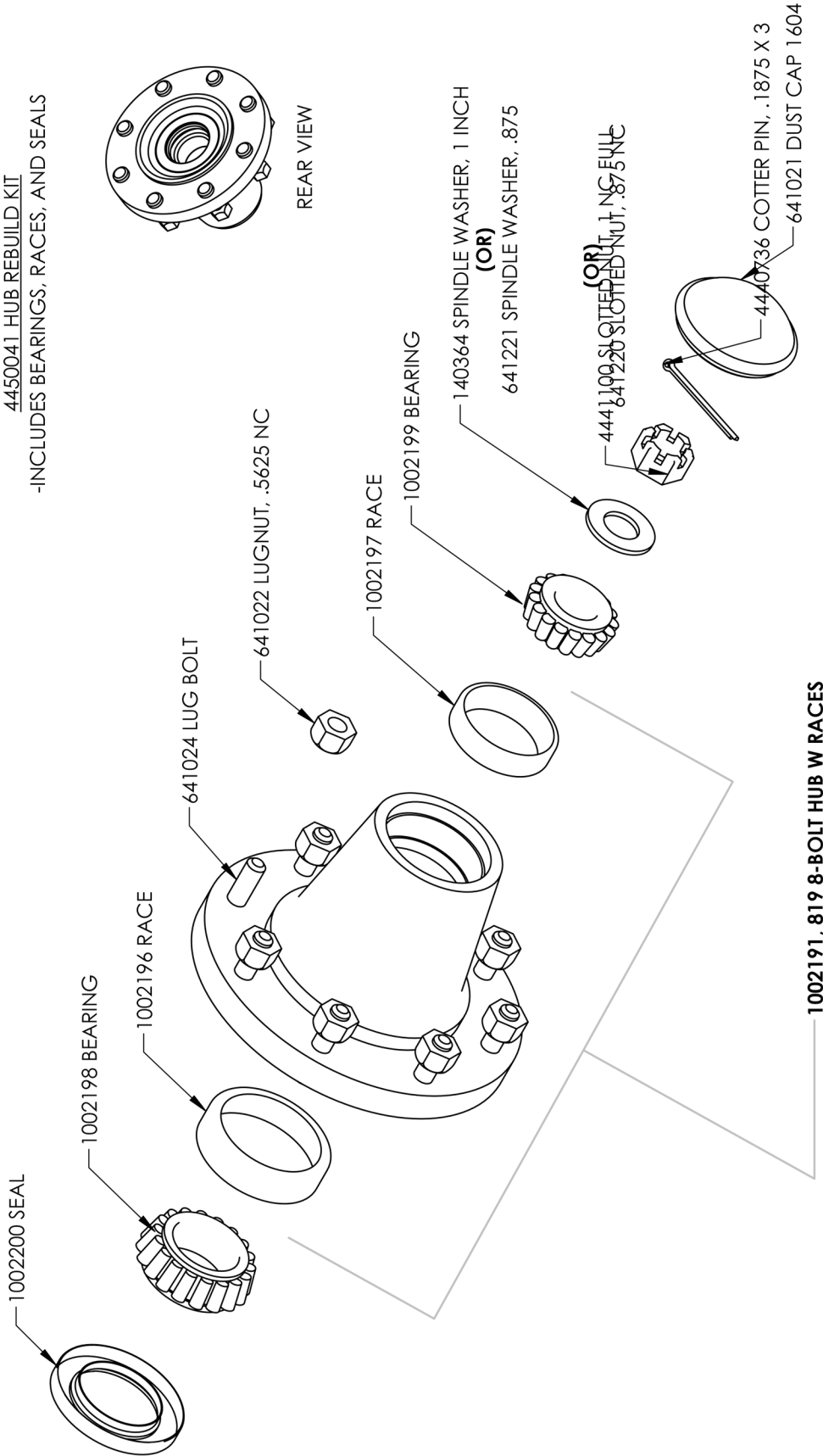

1002194, 819 8-BOLT HUB ASSEMBLY, COMPLETE		DRAWN BY	RICH SMOTHERS	5/4/2009
<p>PROPRIETARY AND CONFIDENTIAL THE INFORMATION CONTAINED IN THIS DRAWING IS THE SOLE PROPERTY OF DALTON AG. ANY REPRODUCTION IN PART OR AS A WHOLE WITHOUT THE WRITTEN PERMISSION OF DALTON AG IS PROHIBITED.</p>		CHECKED BY		
		PRINT DATE	2/10/2023	
		CONFIG.	Default	
DWG:		1002194, 819 8-BOLT HUB ASSEMBLY, COMPLETE		
SIZE	A	SHEET TITLE:	Sheet1	REV
SCALE:	1:4			SHEET 1 OF 1

2001113, 758 8-BOLT HUB ASSEMBLY

2001113, 758 8-BOLT HUB ASSEMBLY

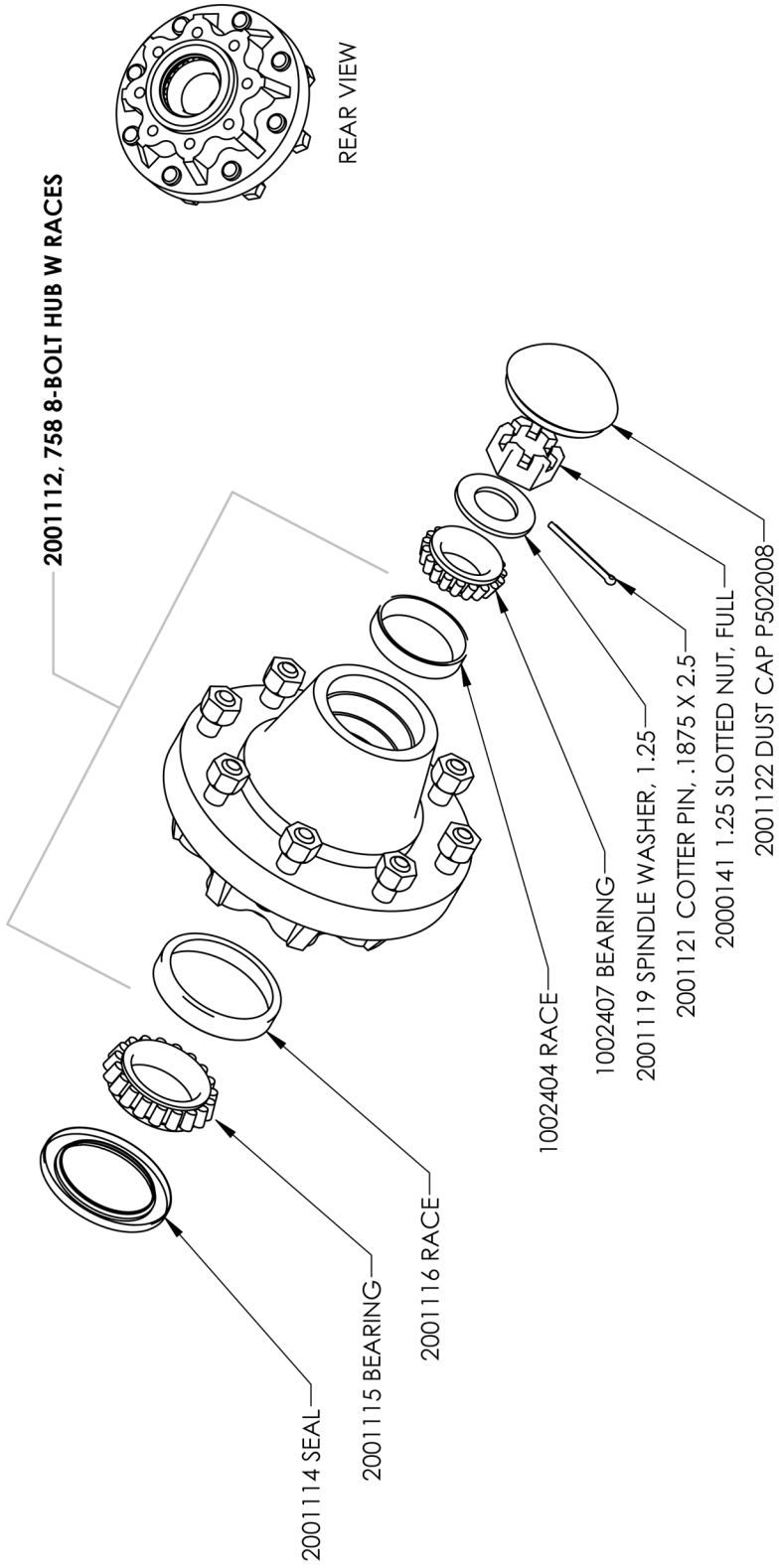

2001118 LUG NUT, .625 NC - Quantity - 8
 2001117 LUG BOLT, .625 NC - Quantity - 8

2001113, 758 8-BOLT HUB ASSEMBLY

DRAWN BY	RICH SMOTHERS	3/2/2012
CHECKED BY		
PRINT DATE	2/10/2023	
CONFIG.	Default	



DWG: 2001113, 758 8-BOLT HUB ASSEMBLY

PROPRIETARY AND CONFIDENTIAL
 THE INFORMATION CONTAINED IN THIS DRAWING IS THE SOLE PROPERTY OF DALTON AG. ANY REPRODUCTION IN PART OR AS A WHOLE WITHOUT THE WRITTEN PERMISSION OF DALTON AG IS PROHIBITED.

SIZE	A	SHEET TITLE:	Sheet1	REV	A
SCALE:	1:5			SHEET 1 OF 1	

5 4 3 2 1

DT SAFETY HOOP ASSEMBLY

DT SAFETY HOOP ASSEMBLY

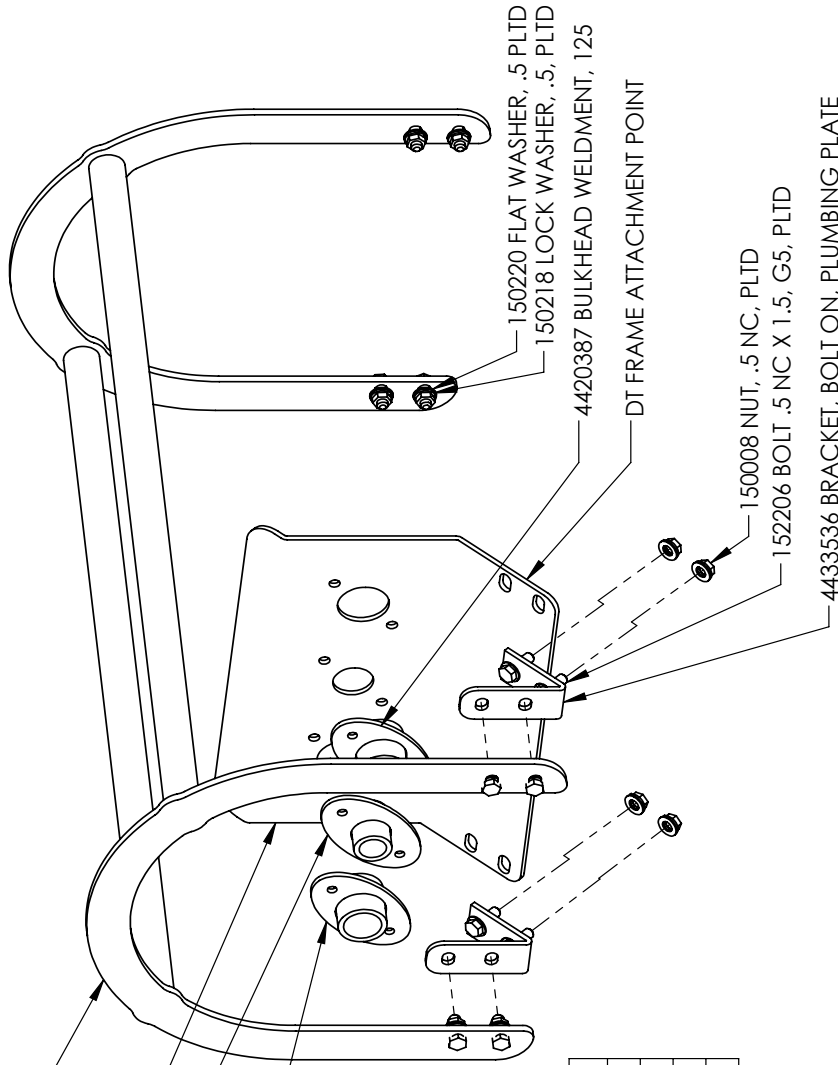

4420638 SAFETY HOOP, WNDT

DT 4433539 PLUMBING PLATE, WNDT

4420386 BULKHEAD WELDMENT, 100

4420387 BULKHEAD WELDMENT, 125

BULKHEAD WELDMENTS TAKE THE FOLLOWING HARDWARE

ITEM	QTY.
151806 BOLT, .375 NC x 1.5, G5, PLTD	6
150212 FLAT WASHER, .375 PLTD	12
150210 LOCK WASHER, .375	6
150005 NUT, .375 NC, PLTD	6

ATTACHMENT POINTS TAKE THE FOLLOWING HARDWARE

ITEM	QTY.
152206 .5 NC X 1.5 BOLT	12
150220 .5 FLAT WASHER	24
150218 .5 LOCK WASHER	12
150008 .5 NC NUT	12

PROPRIETARY AND CONFIDENTIAL
 THE INFORMATION CONTAINED IN THIS DRAWING IS THE SOLE PROPERTY OF DALTON A.G. ANY REPRODUCTION IN PART OR AS A WHOLE WITHOUT THE WRITTEN PERMISSION OF DALTON A.G IS PROHIBITED.

DRAWN BY RICH SMOTHERS 6/14/2013
 CHECKED BY
 PRINT DATE 5/21/2015
 CONFIG. Default
 COMMENTS:



DWG: DT SAFETY HOOP ASSEMBLY

SIZE SHEET TITLE: Sheet1 REV
A **A**

SCALE: 1:8 SHEET 1 OF 1

FOR PARTS, CALL 1.800.342.7498

5

4

3

2

1

WNDT1000 AND 1500 TANK CHANNEL ASSEMBLY

WNDT 1000 AND 1500 TANK CHANNEL ASSEMBLY

TANK CHANNEL	DIM A	DIM B	DIM C
WNDT 1000	67"	21"	21"
WNDT 1500	73"	27"	21"

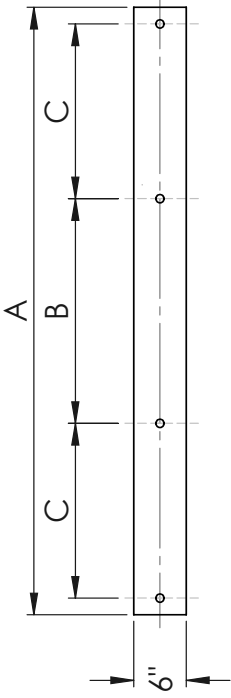

REFERENCE DIMENSIONS TO CONFIRM MODEL

CHANNEL INSTALLATION FASTENERS		QTY.
150010 NUT, .625 NC, PLTD		16
150222 LOCK WASHER, .625, PLTD		16
152416 BOLT, .625 NC x 4.5 G5		16

DT 4420384 TANK MOUNT, CHANNEL 1000
DT 4420388 TANK MOUNT, CHANNEL 1500

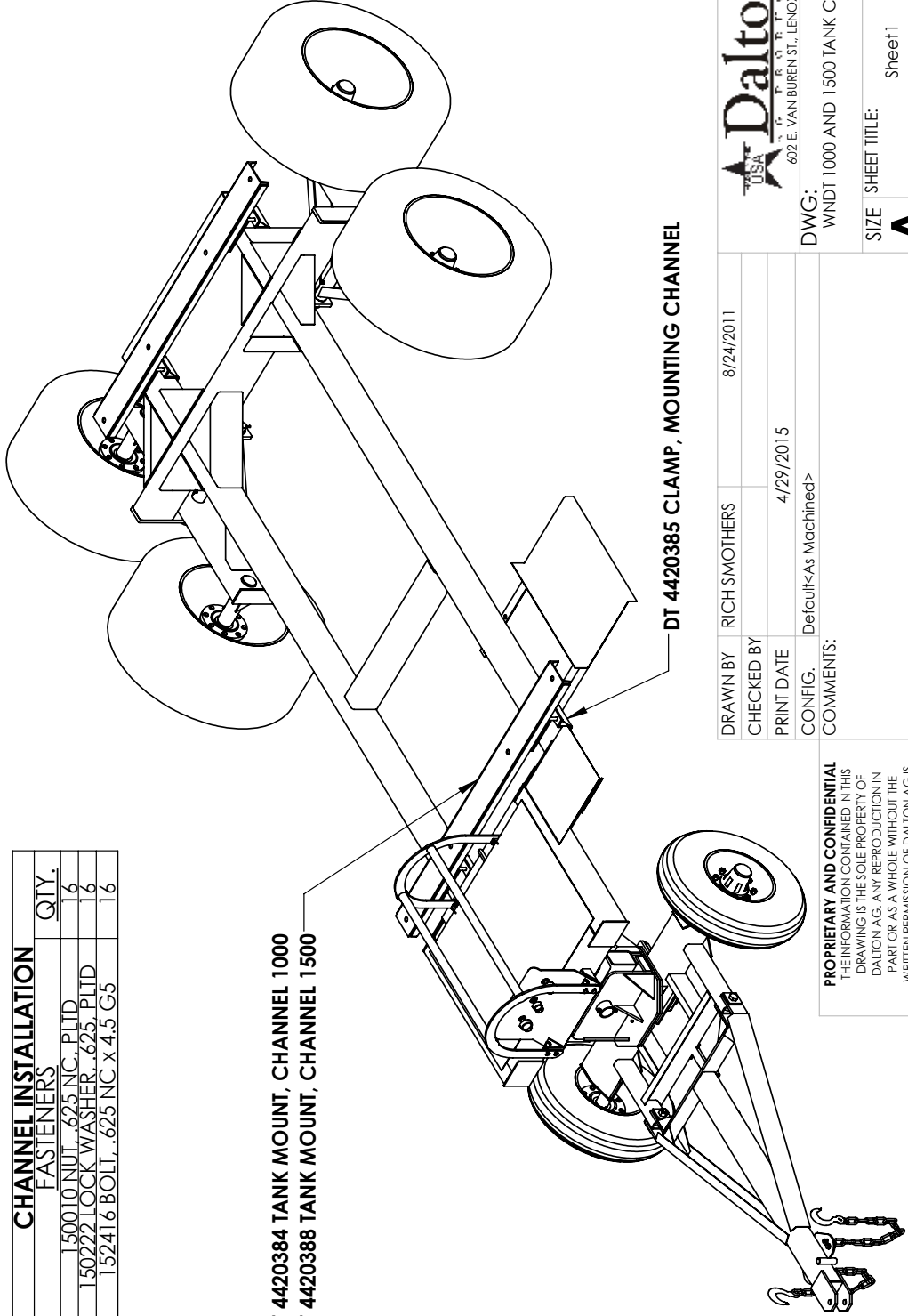

DRAWN BY	RICH SMOTHERS	8/24/2011
CHECKED BY		
PRINT DATE	4/29/2015	
CONFIG.	Default<As Machined>	

Dalton
USA
602 E. VAN BUREN ST., LENOX, IA 50851

DWG: WNDT 1000 AND 1500 TANK CHANNEL ASSEMBLY

SIZE	A	SHEET TITLE:	Sheet1	REV	A
SCALE:	1:30			SHEET 1 OF 1	

PROPRIETARY AND CONFIDENTIAL
THE INFORMATION CONTAINED IN THIS DRAWING IS THE SOLE PROPERTY OF DALTON A.G. ANY REPRODUCTION IN PART OR AS A WHOLE WITHOUT THE WRITTEN PERMISSION OF DALTON A.G IS PROHIBITED.

FOR PARTS, CALL 1.800.342.7498

5	4	3	2	1
---	---	---	---	---

BOLT-ON STEP AND HOSE HOLDER WELDMENTS

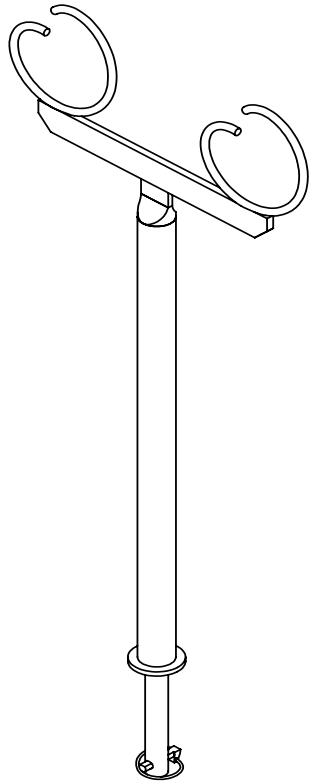

4410237 HOSE HOLDER STAND FOR WNDT

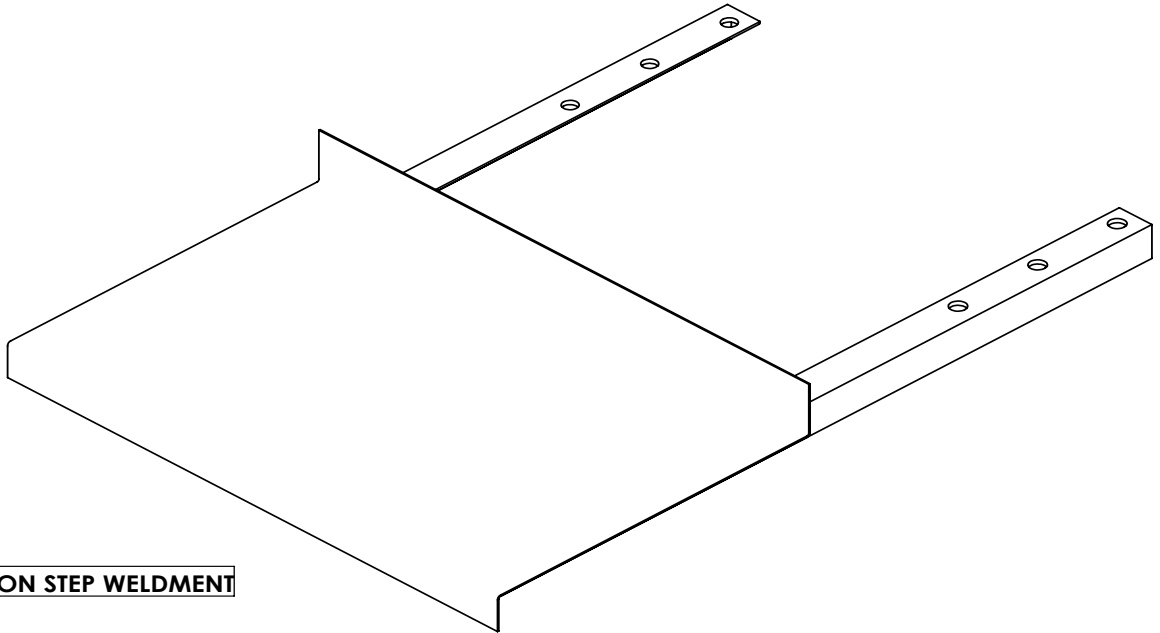

4420524 BOLT ON STEP WELDMENT

DRAWN BY	RICH SMOTHERS	8/13/2013
CHECKED BY		
PRINT DATE	4/23/2015	
CONFIG.	Default	
COMMENTS:		



PROPRIETARY AND CONFIDENTIAL
 THE INFORMATION CONTAINED IN THIS DRAWING IS THE SOLE PROPERTY OF DALTON AG. ANY REPRODUCTION IN PART OR AS A WHOLE WITHOUT THE WRITTEN PERMISSION OF DALTON AG IS PROHIBITED.

DWG: BOLT ON STEP AND HOSE HOLDER WELDMENTS

SIZE	SHEET TITLE:	REV
A	Sheet1	A
SCALE: 1:8	SHEET 1 OF 1	

FOR PARTS, CALL 1.800.342.7498

TANK MOUNTING HARDWARE

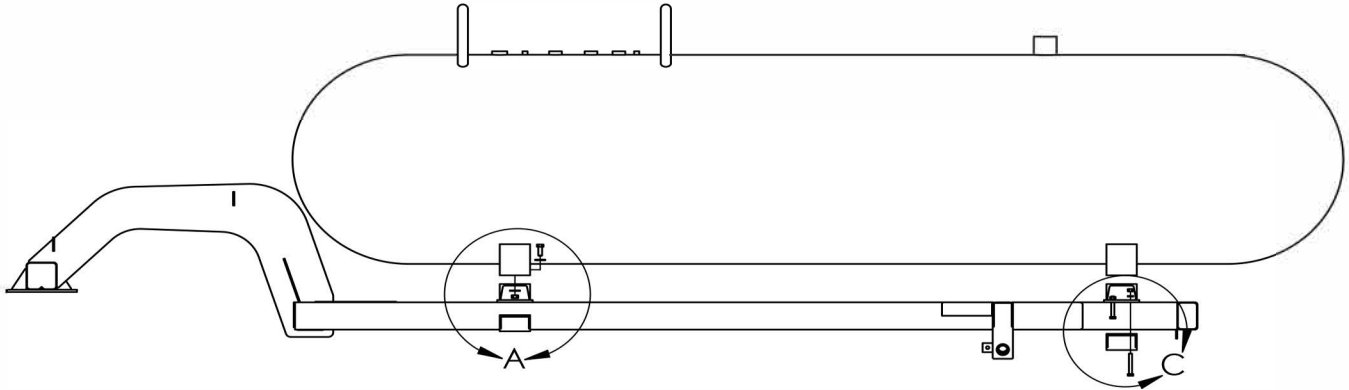

TANK MOUNTING CHANNEL INFORMATION

PART NUMBER	DESCRIPTION	DIM A	DIM B	DIM C
4420384	WNDT GN 1000	67"	21"	21"
4420388	WNDT GN 1500	73"	27"	21"
4420389	WNDT GN 2000	53 1/2"	21"	XX
4420390	WNDT GN 3000	53 1/2"	30 1/4"	XX

MOUNTING: TANK TO TANK MOUNTING CHANNEL

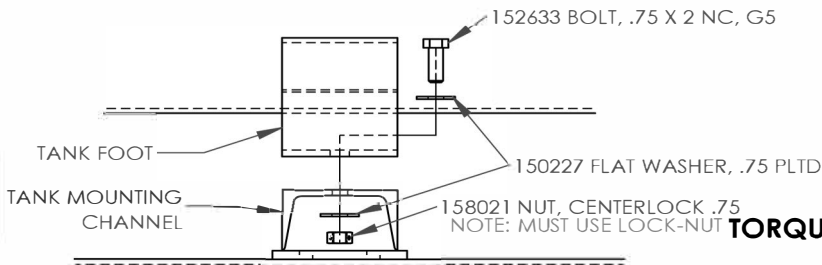

DETAIL A
SCALE 1 : 10

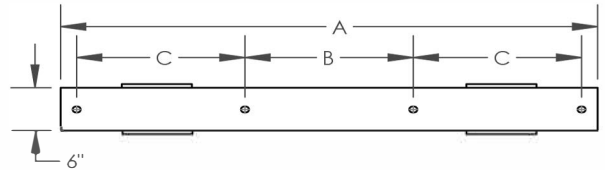

TORQUE TO 250 FT-LBS

MOUNTING: TANK MOUNTING CHANNEL TO WAGON FRAME

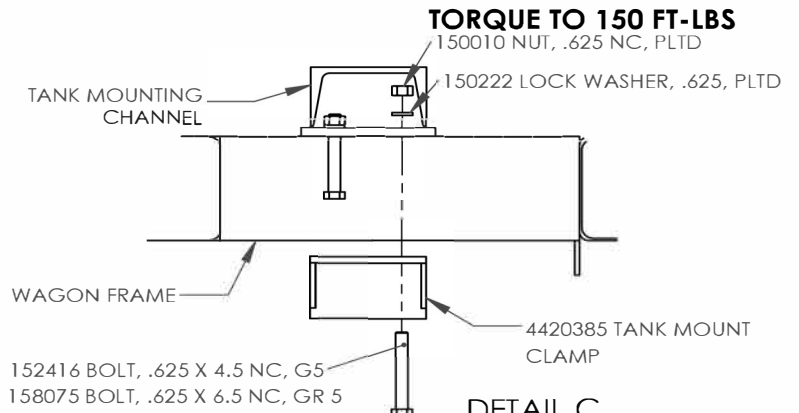

DETAIL C
SCALE 1 : 10

DRAWN BY	--	11/21/2023
CHECKED BY		
PRINT DATE	10/14/2025	
CONFIG.	Default	
COMMENTS:		



PROPRIETARY AND CONFIDENTIAL
THE INFORMATION CONTAINED IN THIS DRAWING IS THE SOLE PROPERTY OF DALTON AG. ANY REPRODUCTION IN PART OR AS A WHOLE WITHOUT THE WRITTEN PERMISSION OF DALTON AG IS PROHIBITED.

DWG: TANK MOUNTING HARDWARE

SIZE	SHEET TITLE:	REV
A	Sheet1	C
SCALE: 1:96	SHEET 1 OF 1	

FOR PARTS, CALL 1.800.342.7498

WNDT1000SA AXLE WELDMENT AND HUB

WNDT 1000SA AXLE WELDMENT AND HUB

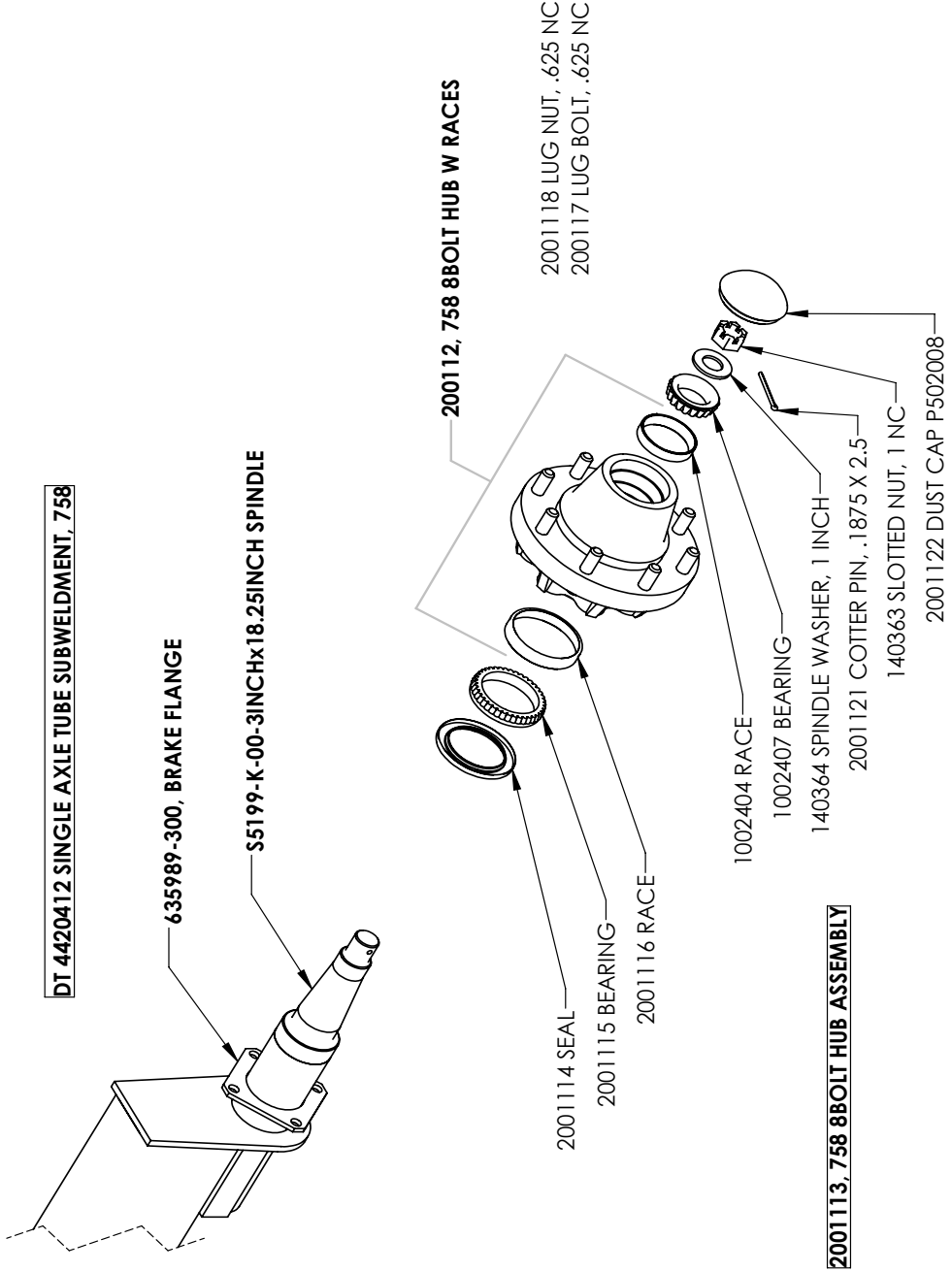

Dalton
USA
602 E. VAN BUREN ST., LENOX, IA 50851

DWG: WNDT 1000SA AXLE WELDMENT AND HUB

SIZE: **A** SHEET TITLE: Sheet1 REV: **A**

SCALE: 1:8 SHEET 1 OF 1

DRAWN BY	RICH SMOTHERS	3/2/2012
CHECKED BY		
PRINT DATE	5/7/2015	
CONFIG.	Default	
COMMENTS:		

PROPRIETARY AND CONFIDENTIAL
THE INFORMATION CONTAINED IN THIS DRAWING IS THE SOLE PROPERTY OF DALTON A.G. ANY REPRODUCTION IN PART OR AS A WHOLE WITHOUT THE WRITTEN PERMISSION OF DALTON A.G IS PROHIBITED.

FOR PARTS, CALL 1.800.342.7498

4410868 WALKER ASSEMBLY, NO BRAKES, 819 HUBS

4410868 WALKER ASSY, NO BRAKES, 819 HUBS

ITEM	PART #	DESCRIPTION	QTY.
1	158300	BOLT .625 X 5.5 NC GR8 PLTD	2
2	188082	NUT .625 NC, CENTERLOCK, PLTD	2
3	152915	GREASE ZERK .125 MPT, 45°	2
4	4431293	BRASS BUSHING, MACHINED	2
5	HUB 819	8 BOLT HUB	1
6	1002196	RACE	1
7	1002197	RACE	1
8	1002198	BEARING	1
9	1002200	SEAL	1
10	1002199	BEARING	1
11	140364	SPINDLE WASHER	1
12	4441100	SLOTTED NUT, 1 NC-FULL	1
13	4440736	COTTER PIN, .1875 X 3	1
14	641021	DUST CAP	1
15	641022	LUG NUT .5625-18	8

NOTES:

1002194- COMPLETE 8 BOLT HUB ASSEMBLY
 1002191-HUB WITH RACES

OLD REFERENCED PART NUMBERS
 4410242-A-BK
 4410243-A-BK

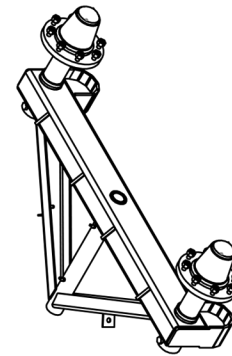
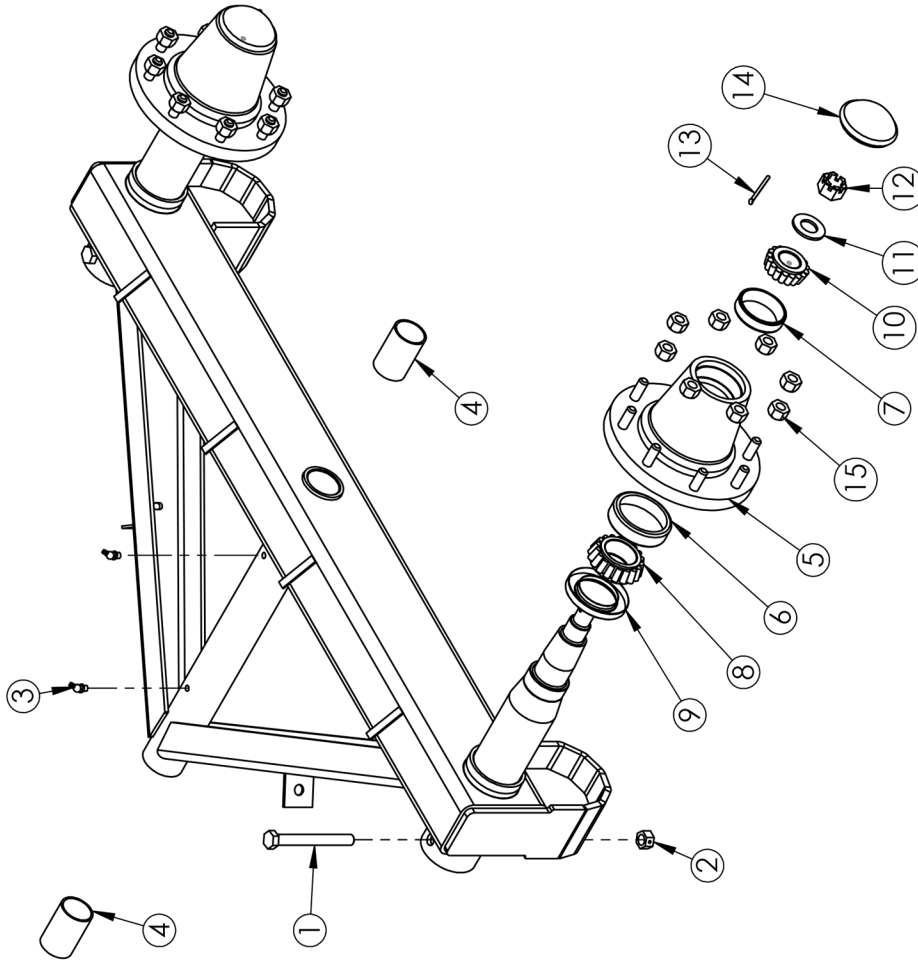

UNLESS OTHERWISE SPECIFIED
 TOLERANCES TO BE:
 ANGLES: ± 1.0°
 FRACTIONS <6": ±1/32, >6": 1/16
 X.X: ±0.06
 X.XX: ±0.03
 X.XXX: ±0.005

DRAWN BY: Tyler Jackson
 CHECKED BY:
 PRINT DATE: 6/3/2024
 CONFIG: Default
 COMMENTS:

Dalton
 USA
 602 E. VAN BUREN ST., LENOX, IA 50851
 DWG: 4410868

WALKER ASSY 819 NO BRAKES EXPLODED

SIZE SHEET TITLE: MANUAL Sheet
 REV

SCALE: 1:32 SHEET 1 OF 1

PROPRIETARY AND CONFIDENTIAL
 THE INFORMATION CONTAINED IN THIS DRAWING IS THE SOLE PROPERTY OF DALTON AG. ANY REPRODUCTION IN PART OR AS A WHOLE WITHOUT THE WRITTEN PERMISSION OF DALTON AG IS PROHIBITED.

C:\SOLIDWORKS Data\LEPDM_Vault\Wagons\WIND\DT ASSEMBLES\

4410869 WALKER ASSEMBLY, 819 HUBS, 1 BRAKE LH

4410869 WALKER ASSY, 819 HUBS, 1 BRAKE LH

ITEM NO.	PART NUMBER	DESCRIPTION	QTY.
1	4421765	WALKER, BOLT IN SPINDLE	1
2	4431422	SPINDLE, BOLT ON, 3.00X20.00 819 HUB	2
3	635989-300	BRAKE FLANGE, 300	1
4	158300	BOLT .625 X 5.5 NC GR8 PLTD	2
5	188082	NUT, .625 NC, CENTERLOCK, PLTD	2
6	152915	GREASE ZERK .125 MPT, 45°	2
7	4431293	BRASS BUSHING, MACHINED	2
8	HUB 819		2
9	1002196	BEARING CUP, INNER 8B	2
10	1002197	BEARING CUP, OUTER 8B S, HD WALKER, 3" OD	2
11	1002198	BEARING CONE, INNER 8B S, 2" BORE	2
12	1002200	SEAL, 819 (8B S), 2.5" X 3.75" X .438 SA STYLE LIP	2
13	1002199	BEARING CONE, OUTER 8B S	2
14	140364	WASHER, 1", 1" SAE FLAT WASHER	2
15	4441100	SLOTTED NUT, 1 NC FULL	2
16	4440736	COTTER PIN, .1875 X 3	2
17	641021	DUST CAP, 8-BOLT SMOOTH OR RIBBED HUB (1000885)	2
18	641022	LUG NUT .5625-18	16
19	641030	BRAKE CLUSTER, 13" LH	1
20	641028	BRAKE DRUM, 13 INCH	1
21	152201	BOLT .5 X 1 NC PLTD	4
22	150218	LOCK WASHER, .5 PLTD	4
23	150008	NUT, .5 NC, GR 5, PLTD	4

**NOTES:
LH IS SHOWN**

RH IS 4410870 WITH THE FOLLOWING CHANGES

*ITEM 1 IS 4410862

*ITEM 19 IS 631029

*SWAPPED SPINDLE ORIENTATION

OLD REFERENCED PART NUMBERS

4410242-1A-BK(LH)

4410243-1A-BK(RH)

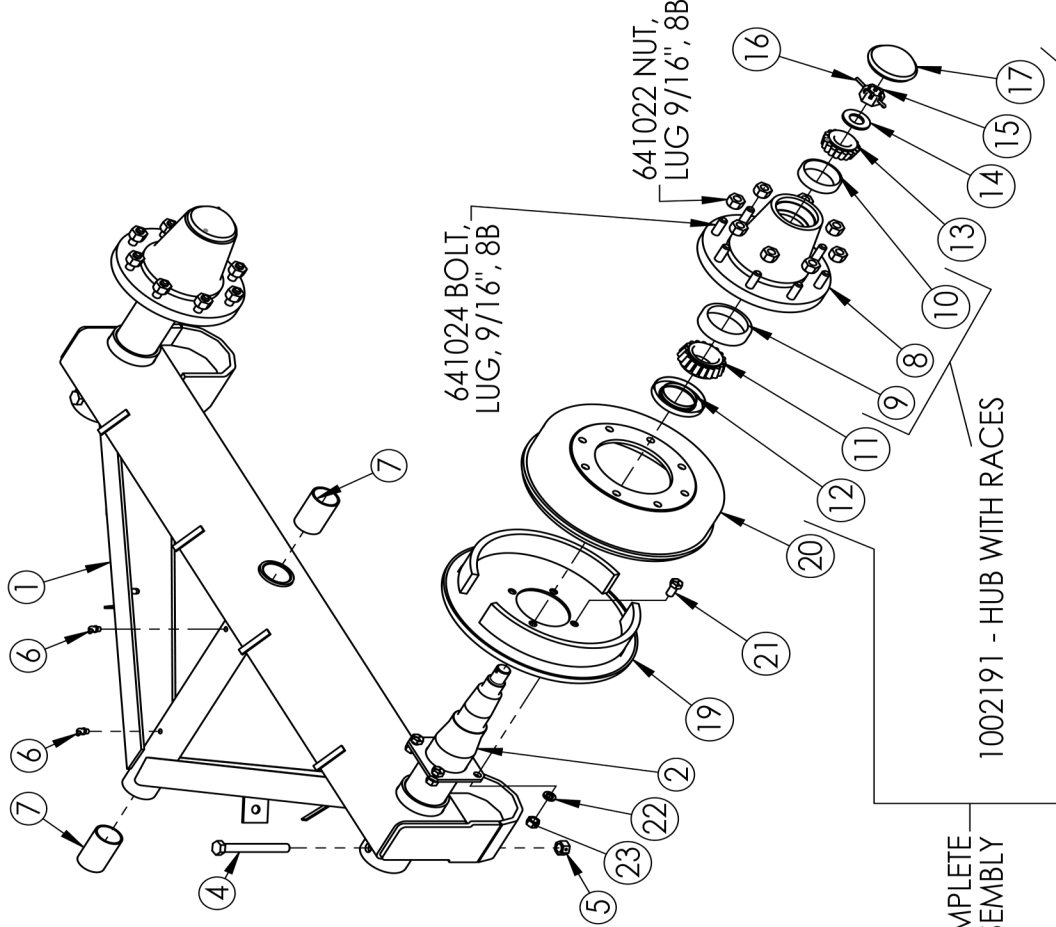

1002194 - COMPLETE
HUB ASSEMBLY

1002191 - HUB WITH RACES

UNLESS OTHERWISE SPECIFIED
TOLERANCES TO BE:
ANGLES: ±1.0°
FRACTIONS <6\"/>

DRAWN BY Tyler Jackson 4/29/2024
CHECKED BY
PRINT DATE 4/30/2026
CONFIG. Default
COMMENTS:



DWG: 4410869

WALKER ASSY 819 HUBS 1 BRAKE FLANGE LH

SIZE **A** SHEET TITLE: Sheet1 REV **A**

SCALE: 1:32 SHEET 1 OF 1

PROPRIETARY AND CONFIDENTIAL

THE INFORMATION CONTAINED IN THIS DRAWING IS THE SOLE PROPERTY OF DALTON AG. ANY REPRODUCTION IN PART OR AS A WHOLE WITHOUT THE WRITTEN PERMISSION OF DALTON AG IS PROHIBITED.

C:_EPDM_Vault\Wagons\WINDT\DT ASSEMBLIES\

4420871 WALKER ASSY, 819 HUBS, 4 WHEEL BRAKES

ITEM NO.	PART NUMBER	DESCRIPTION	QTY.
1	4421765	WALKER, BOLT IN SPINDLE	1
2	4431422	SPINDLE, BOLT ON, 3.00X20.00 819 HUB	2
3	635989-300	BRAKE FLANGE, 300	2
4	152416	BOLT, .625 X 4.5 NC, G5 PL	2
5	188082	NUT, .625 NC, CENTERLOCK, PLTD	2
6	152915	GREASE ZERK, .125 MPT, 45°	2
7	4431293	BRASS BUSHING, MACHINED	2
8	4441270	93929 TEE, BRAKE LINE	1
9	HUB 819		2
10	1002196	BEARING CUP, INNER 8B	2
11	1002197	BEARING CUP, OUTER 8B S, HD WALKER, 3" OD	2
12	1002198	BEARING CONE, INNER 8B S, 2" BORE	2
13	1002200	SEAL, 819 (8B S), 2.5" X 3.75" X .438 SA STYLE LIP	2
14	1002199	BEARING CONE, OUTER 8B S	2
15	140364	WASHER, 1", 1" SAE FLAT WASHER	2
16	4441100	SLOTTED NUT, 1 NC FULL	2
17	4440736	COITER PIN, .1875 X 3	2
18	641021	DUST CAP, 8-BOLT SMOOTH OR RIBBED HUB (1000885)	2
19	641022	LUG NUT, .5625-18	16
20	641030	BRAKE CLUSTER, 13" LH	2
21	641028	BRAKE DRUM, 13 INCH	2
22	152243	BOLT, .5 X 1.5 NF PLN	4
23	150009	NUT, .5 NF PLTD	4
24	152201	BOLT, .5 X 1 NC PLTD	4
25	150218	LOCK WASHER, .5 PLTD	4
26	150008	NUT, .5 NC, GR 5, PLTD	4

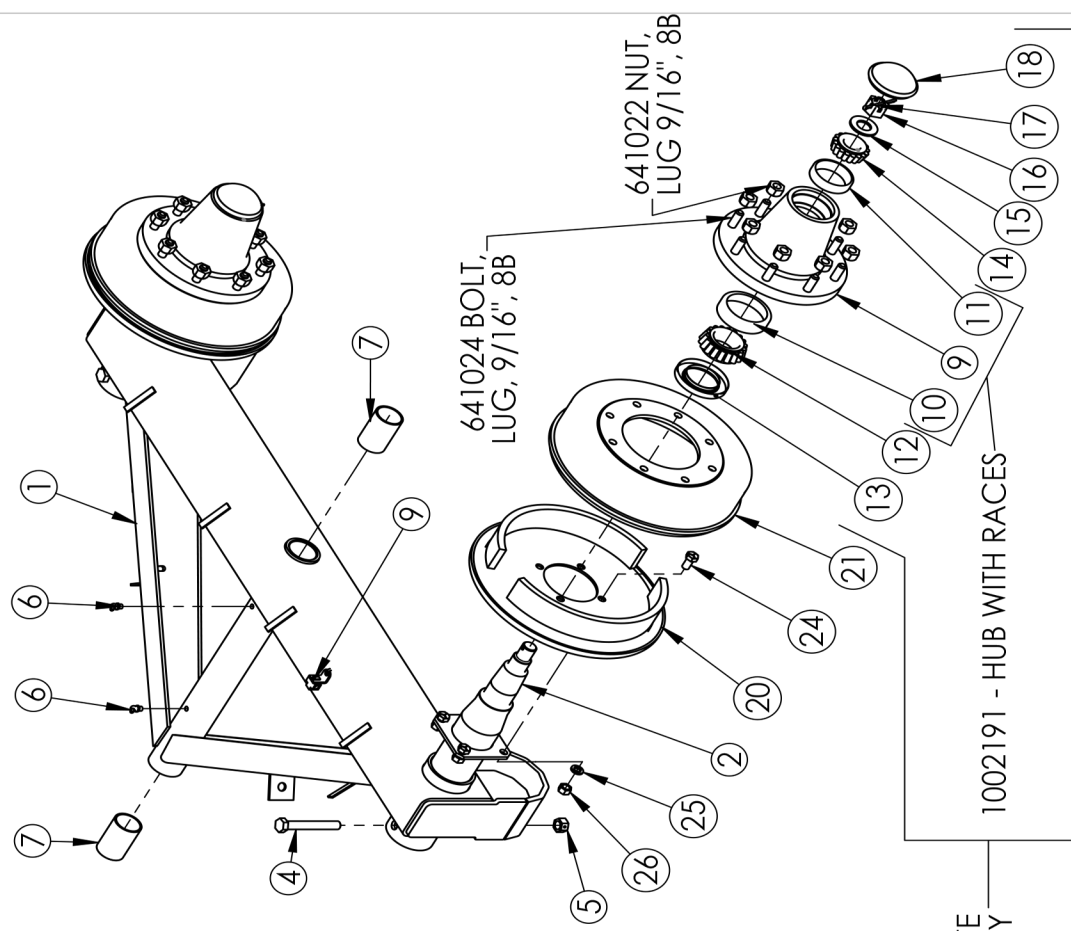

**NOTES:
LH IS SHOWN**

RH IS 4410872 WITH THE FOLLOWING CHANGES
 *ITEM 1 IS 4410863-R
 *ITEM 21 IS 641029
 *SWAPPED SPINDLE ORIENTATION

OLD REFERENCED PART NUMBERS
 4410242-2A-BK (LH)
 4410243-2A-BK (RH)

DRAWN BY	Tyler Jackson	6/13/2024
CHECKED BY		
PRINT DATE	4/30/2026	
CONFIG.	Default	
COMMENTS:		



DWG: 4410871

WALKER ASSY 819 HUBS 2 BRAKE FLANGE LH

SIZE	A	SHEET TITLE:	Sheet1	REV	A
------	---	--------------	--------	-----	---

SCALE: 1:32 SHEET 1 OF 1

PROPRIETARY AND CONFIDENTIAL
 THE INFORMATION CONTAINED IN THIS DRAWING IS THE SOLE PROPERTY OF DALTON AG. ANY REPRODUCTION IN PART OR AS A WHOLE WITHOUT THE WRITTEN PERMISSION OF DALTON AG IS PROHIBITED.

C:\EPDM_Vault\Wagons\WINDT\DT ASSEMBLIES\ 3 2 1

4410873 WALKER ASSEMBLY, NO BRAKES, 758 HUBS

4410873 WALKER ASSY, NO BRAKES, 758 HUBS

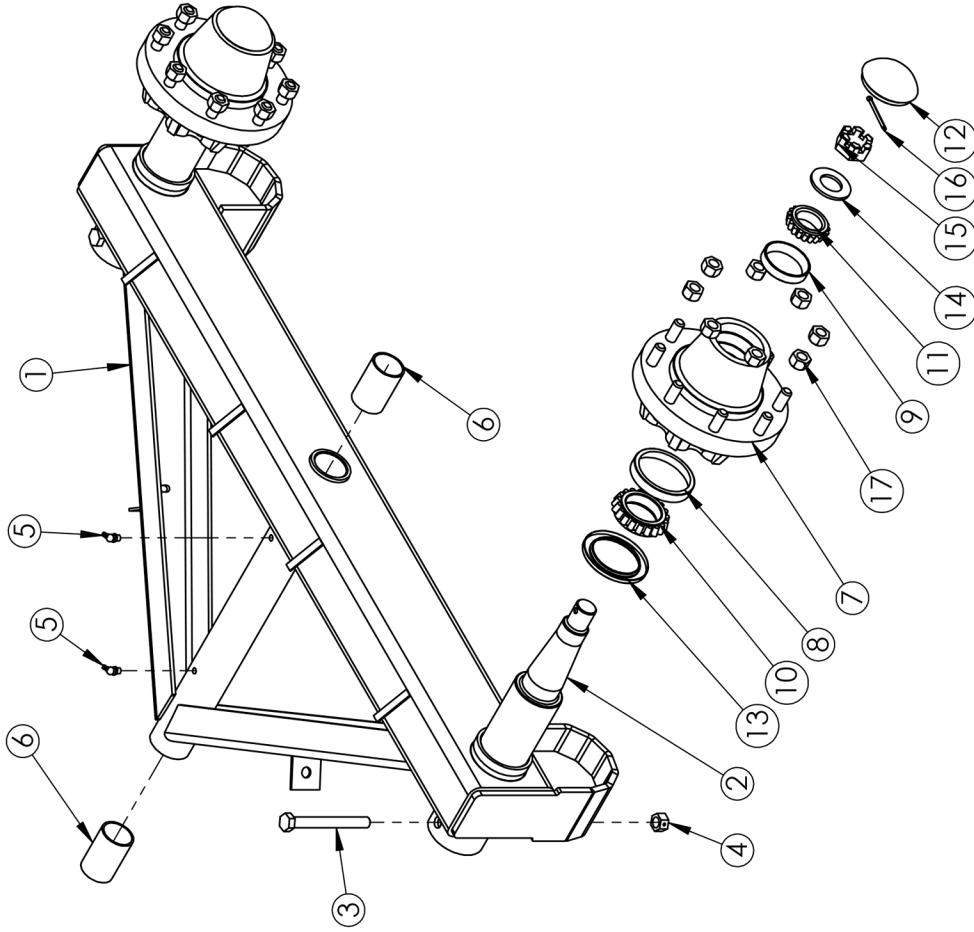

ITEM NO.	PART NUMBER	DESCRIPTION	QTY.
1	4421765	WALKER, BOLT IN SPINDLE	1
2	4431419	SPINDLE, BOLT IN, 758 HUB	2
3	158300	BOLT .625 X 5.5 NC GR8 PLTD	2
4	188082	NUT, .625 NC, CENTERLOCK, PLTD	2
5	152915	GREASE ZERK .125 MPT, 45°	2
6	4431293	BRASS BUSHING, MACHINED	2
7	HUB 758	8 BOLT HUB	1
8	2001116	RACE, 3.8125 OD X .625	1
9	1002404	BEARING CUP, 2.891 OD X .580 W	1
10	2001115	BEARING CONE, 2.25 ID X .8640	1
11	1002407	BEARING CONE, 1.625 ID X .780	1
12	2001122	DUST CAP, 88 H 758	1
13	2001114	SEAL, 758 (88 H), 3" X 4" X .25" GREASE SEAL	1
14	2001119	WASHER, SAE FLAT, 1.25 PLATED	1
15	2000141	NUT, 1-1/4 - 12 SLOTTED HEX SAE	1
16	2001121	COTTER PIN, 3/16" X 2-1/2"	1
17	2001118	NUT, 5/8" FLANGE, 88 H	8

NOTES:

2001112- HUB WITH RACES
 2001113-COMPLETE HUB ASSEMBLY

OLD REFERENCED PART NUMBERS
 4410244-A-BK
 4410245-A-BK

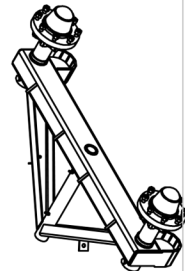

UNLESS OTHERWISE SPECIFIED
 TOLERANCES TO BE:
 ANGLES: ± 1.0°
 FRACTIONS <6": ±1/32, >6": 1/16
 X.X: ± 0.06
 X.XX: ± 0.03
 X.XXX: ± 0.005

PROPRIETARY AND CONFIDENTIAL
 THE INFORMATION CONTAINED IN THIS DRAWING IS THE SOLE PROPERTY OF DALTON AG. ANY REPRODUCTION IN
 PART OR AS A WHOLE WITHOUT THE WRITTEN PERMISSION OF DALTON AG IS PROHIBITED.

DRAWN BY: Tyler Jackson
 CHECKED BY:
 PRINT DATE: 6/3/2024
 CONFIG: Default
 COMMENTS:



DWG: 4410873

WALKER ASSY 758 NO BRAKES EXPLODED

SIZE SHEET TITLE: A Sheet1
 REV

SCALE: 1:32 SHEET 1 OF 1

4410874 WALKER ASSY, 758 HUBS, 1 BRAKE LH

ITEM NO.	PART NUMBER	DESCRIPTION	QTY
1	4431419	SPINDLE, BOLT IN, 758 HUB	1
2	4421767	SPINDLE, BOLT IN, 758 HUB, WITH BRAKE FLANGE	1
3	158300	BOLT .625 X 5.5 NC GR8 PLTD	2
4	188082	NUT, .625 NC, CENTERLOCK, PLTD	2
5	152915	GREASE ZERK .125 MPT, 45°	2
6	4431293	BRASS BUSHING, MACHINED	2
7	9643	WALKER SHAFT	1
8	2001113	HUB, COMPLETE, 8 BOLT, 758	2
9	2001116	RACE, 3.8125 OD X .625	2
10	1002404	BEARING CUP, 2.891 OD X .580 W	2
11	2001115	BEARING CONE, 2.25 ID X .8640	2
12	1002407	BEARING CONE, 1.625 ID X .780	2
13	2001122	DUST CAP, 8B H 758	2
14	2001114	SEAL, 758 (8B H), 3" X 4" X .25" GREASE SEAL	2
15	2001119	WASHER, SAE FLAT, 1.25 PLATED	2
16	2000141	NUT, 1-1/4 - 12 SLOTTED HEX SAE	2
17	2001121	COTTER PIN, 3/16" X 2-1/2"	2
18	2001118	NUT, 5/8" LUG, 8B H	16
20	4440856	BRAKE DRUM 13" X 5.5" BC	1
21	152239	BOLT .5 X 1 NF PLTD	8
22	641030	BRAKE CLUSTER, 13" LH	1
23	150218	LOCK WASHER, .5 PLTD	12
24	152201	BOLT .5 X 1 NC PLTD	4
25	150008	NUT, .5 NC, GR 5, PLTD	4
26	4421765	WALKER, BOLT IN SPINDLE	1

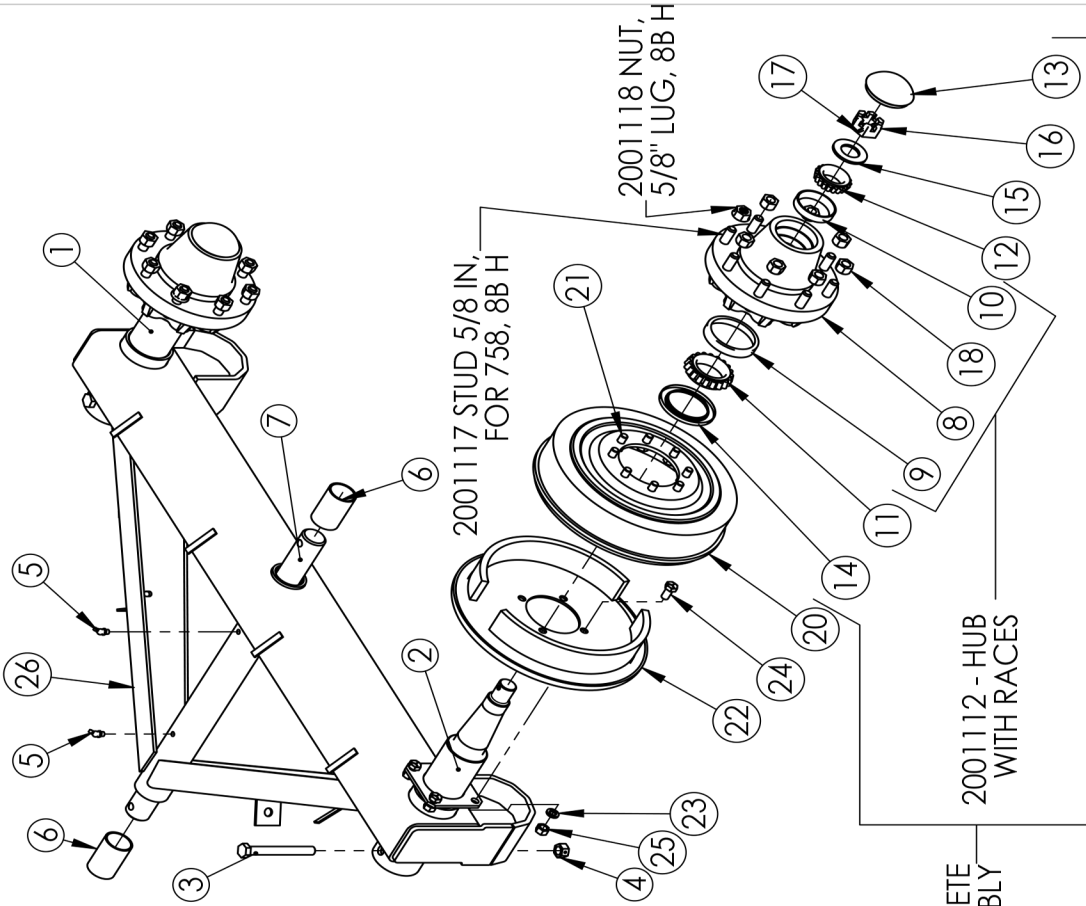

**NOTES:
LH IS SHOWN**

RH IS 4410875 WITH THE FOLLOWING CHANGES
 * ITEM 1 IS 4410866
 * ITEM 20 IS 631029
 * SWAPPED SPINDLE ORIENTATION

OLD REFERENCED PART NUMBERS:
 4410244-1A-BK(LH)
 4410245-1A-BK(RH)

2001113 - COMPLETE
 HUB ASSEMBLY

2001112 - HUB
 WITH RACES



DRAWN BY	Tyler Jackson	4/29/2024
CHECKED BY		
PRINT DATE	4/30/2026	
CONFIG.	Default	
COMMENTS:		

UNLESS OTHERWISE SPECIFIED
 TOLERANCES TO BE:
 ANGLES: ± 1.0°
 FRACTIONS <6": ±1/32, >6": 1/16
 X.X: ± 0.06
 X.XX: ± 0.03
 X.XXX: ± 0.005

DWG: 4410874

WALKER ASSY 758 HUBS 1 BRAKE FLANGE LH

SIZE	A	SHEET TITLE:	Sheet1	REV	A
------	---	--------------	--------	-----	---

SCALE: 1:32 SHEET 1 OF 1

PROPRIETARY AND CONFIDENTIAL
 THE INFORMATION CONTAINED IN THIS DRAWING IS THE SOLE PROPERTY OF DALTON AG. ANY REPRODUCTION IN PART OR AS A WHOLE WITHOUT THE WRITTEN PERMISSION OF DALTON AG IS PROHIBITED.

4410876 WALKER ASSY, 758 HUBS, 4 WHEEL BRAKES

ITEM NO.	PART NUMBER	DESCRIPTION	QTY.
1	4421765	WALKER, BOLT IN SPINDLE	1
2	4421767	SPINDLE, BOLT IN, 758 HUB, WITH BRAKE FLANGE	2
3	152416	BOLT, .625 X 4.5 NC, G5 PL	2
4	188082	NUT, .625 NC, CENTERLOCK, PLTD	2
5	152915	GREASE ZERK, .125 MPT, 45°	2
6	4431293	BRASS BUSHING, MACHINED	2
7	2001113	HUB, COMPLETE, 8 BOLT, 758	2
8	2001116	RACE, 3.8125 OD X .625	2
9	1002404	BEARING CUP, 2.891 OD X .580 W	2
10	2001115	BEARING CONE, 2.25 ID X .8640	2
11	1002407	BEARING CONE, 1.625 ID X .780	2
12	2001122	DUST CAP, 8B H 758	2
13	2001114	SEAL, 758 (8B H), 3" X 4" X .25" GREASE SEAL	2
14	2001119	WASHER, SAE FLAT, 1.25 PLATED	2
15	2000141	NUT, 1-1/4 - 12 SLOTTED HEX SAE	2
16	2001121	COTTER PIN, 3/16" X 2-1/2"	2
19	4440856	BRAKE DRUM 13" X 8 X 5.5" BC	2
20	152239	BOLT .5 X 1 NF PLTD	16
21	641030	BRAKE CLUSTER, 13" LH	2
22	150218	LOCK WASHER, .5 PLTD	24
23	152201	BOLT .5 X 1 NC PLTD	8
24	150008	NUT, .5 NC, GR 5, PLTD	8
25	4441270	93929 TEE, BRAKE LINE	1

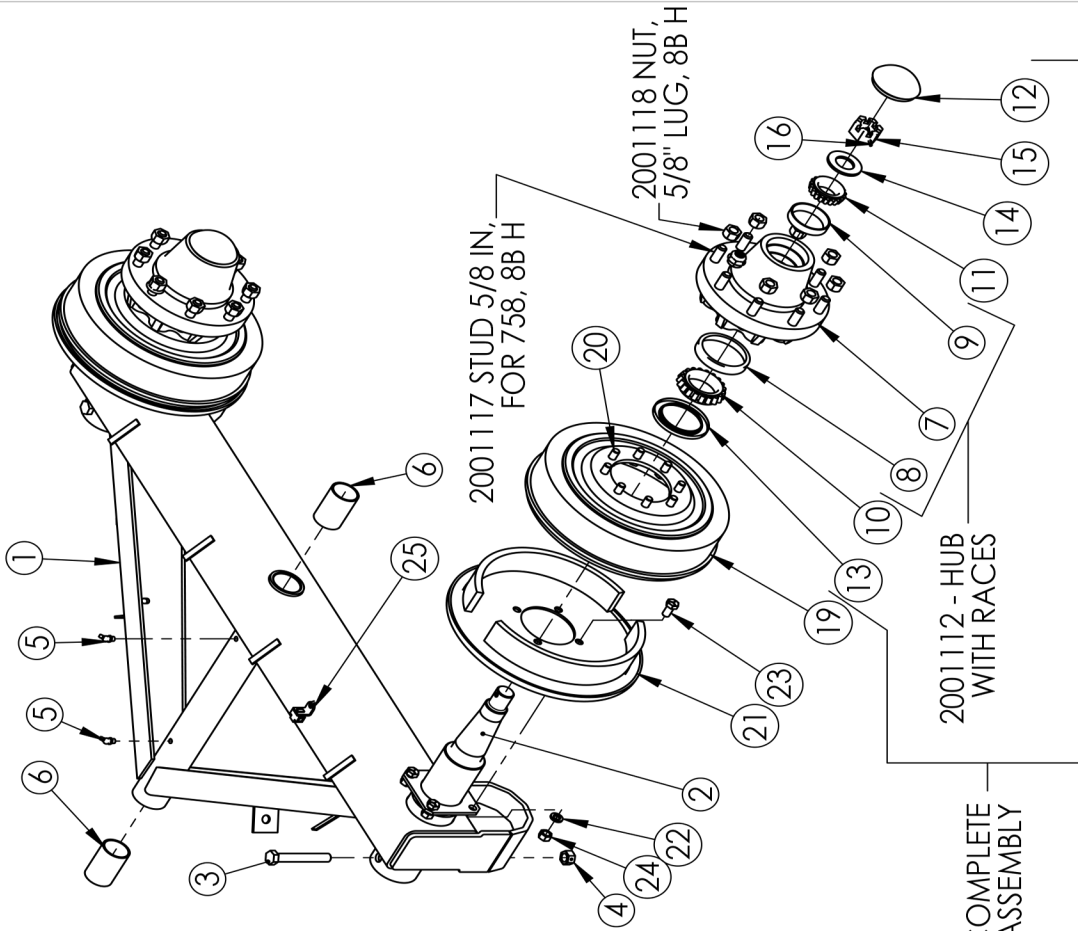

NOTES:
LH IS SHOWN

RH IS 4410877 WITH THE FOLLOWING CHANGES
 *ITEM 1 IS 4410867-R
 *ITEM 21 IS 641029
 *ITEM 8 ORIENTATION OFFSET FLIPPED

OLD REFERENCED PART NUMBERS
 4410244-2A-BK(LH)
 4410245-2A-BK(RH)

2001113 - COMPLETE HUB ASSEMBLY

2001112 - HUB WITH RACES



DRAWN BY	Tyler Jackson	4/29/2024
CHECKED BY		
PRINT DATE	4/30/2026	
CONFIG.	Default	
COMMENTS:		

DWG: 4410876
 WALKER ASSY 758 HUBS 4 WHEEL BRAKES
 SIZE SHEET TITLE: A Sheet
 REV A
 SCALE: 1:32 SHEET 1 OF 1

PROPRIETARY AND CONFIDENTIAL
 THE INFORMATION CONTAINED IN THIS DRAWING IS THE SOLE PROPERTY OF DALTON AG. ANY REPRODUCTION IN PART OR AS A WHOLE WITHOUT THE WRITTEN PERMISSION OF DALTON AG IS PROHIBITED.

BRAKE INSTRUCTIONS AND MAINTENANCE

WARNING: To Prevent Serious Injury or Death

FAILURE TO FOLLOW THESE INSTRUCTIONS, OR FAILURE TO PROPERLY MAINTAIN BRAKES AFTER INSTALLATION, CAN RESULT IN LOSS OF BRAKING ACTION. THIS CAN CAUSE PERSONAL INJURY, DEATH OR PROPERTY DAMAGE. ONLY PROFESSIONAL MECHANICS SHOULD INSTALL BRAKE CLUSTERS. HAVE YOUR BRAKES INSPECTED BY A PROFESSIONAL MECHANIC AT LEAST ANNUALLY AFTER INSTALLATION.

WARNING: To Prevent Serious Injury or Death

- Review following instructions before installation and use of hydraulic brakes.
- Dealers or distributors must review these instructions with ultimate user.
- Failure to follow these instructions, or failure to properly maintain braking system after installation, can result in loss of braking action.

Table of Contents

General information.....	2
Safety, Signal Words	3
Bolt Torque	4
Installation and Maintenance	5-6
13" Brake Cluster Breakdown and Parts List	7
13" Brake Drum Comparison Chart.....	8

SAFETY

TAKE NOTE! THIS SAFETY ALERT SYMBOL FOUND THROUGHOUT THIS MANUAL IS USED TO CALL YOUR ATTENTION TO INSTRUCTIONS INVOLVING YOUR PERSONAL SAFETY AND SAFETY OF OTHERS. FAILURE TO FOLLOW THESE INSTRUCTIONS CAN RESULT IN INJURY OR DEATH.



THIS SYMBOL MEANS

ATTENTION

BECOME ALERT

YOUR SAFETY IS INVOLVED!

SIGNAL WORDS

Note use following signal words **DANGER**, **WARNING**, and **CAUTION** with safety messages. Appropriate signal word for each has been selected using following guidelines:

DANGER:

Indicates an imminently hazardous situation that, if not avoided, will result in death or serious injury. This signal word is to be limited to most extreme situations typically for machine components which, for functional purposes, cannot be guarded.

WARNING:

Indicates a potentially hazardous situation that, if not avoided, could result in death or serious injury, and includes hazards that are exposed when guards are removed. It may also be used to alert against unsafe practices.

CAUTION:

Indicates a potentially hazardous situation that, if not avoided, may result in minor or moderate injury. It may also be used to alert against unsafe practices.

If you have questions not answered in this manual, require additional copies, or if your manual is damaged, please contact your dealer or Demco, P.O. Box 189, 4010 320th Street, Boyden, IA 51234
ph: (712) 725-2311 or (712) 725-2302 Toll Free: 1-800-543-3626 Fax: (712) 725-2380
<http://www.demco-products.com>

BOLT TORQUE

TORQUE DATA FOR STANDARD NUTS, BOLTS, AND CAPSCREWS.

Tighten all bolts to torques specified in chart unless otherwise noted. Check tightness of bolts periodically, using bolt chart as guide. Replace hardware with same grade bolt.

NOTE: Unless otherwise specified, high-strength Grade 5 hex bolts are used throughout assembly of equipment.

Bolt Torque for Standard bolts *



Torque Specifications

"A"	GRADE 2		GRADE 5		GRADE 8	
	lb-ft	(N.m)	lb-ft	(N.m)	lb-ft	(N.m)
1/4"	6	(8)	9	(12)	12	(16)
5/16"	10	(13)	18	(25)	25	(35)
3/8"	20	(27)	30	(40)	45	(60)
7/16"	30	(40)	50	(70)	80	(110)
1/2"	45	(60)	75	(100)	115	(155)
9/16"	70	(95)	115	(155)	165	(220)
5/8"	95	(130)	150	(200)	225	(300)
3/4"	165	(225)	290	(390)	400	(540)
7/8"	170	(230)	420	(570)	650	(880)
1"	225	(300)	630	(850)	970	(1310)

Bolt Torque for Metric bolts *

"A"	CLASS 8.8		CLASS 9.8		CLASS 10.9	
	lb-ft	(N.m)	lb-ft	(N.m)	lb-ft	(N.m)
6	9	(13)	10	(14)	13	(17)
7	15	(21)	18	(24)	21	(29)
8	23	(31)	25	(34)	31	(42)
10	45	(61)	50	(68)	61	(83)
12	78	(106)	88	(118)	106	(144)
14	125	(169)	140	(189)	170	(230)
16	194	(263)	216	(293)	263	(357)
18	268	(363)	--	--	364	(493)
20	378	(513)	--	--	515	(689)
22	516	(699)	--	--	702	(952)
24	654	(886)	--	--	890	(1206)

Torque figures indicated are valid for non-greased or non-oiled threads and heads unless otherwise specified. Therefore, do not grease or oil bolts or capscrews unless otherwise specified in this manual. When using locking elements, increase torque values by 5%.

* GRADE or CLASS value for bolts and capscrews are identified by their head markings.

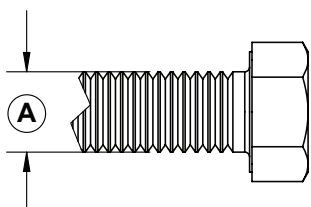

GRADE-2

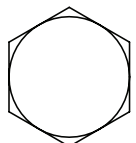

GRADE-5

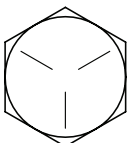

GRADE-8

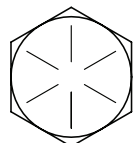

CLASS 8.8

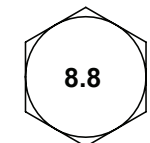

CLASS 9.8

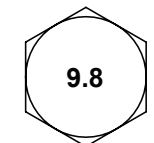

CLASS 10.9



INSTRUCTIONS FOR 13” BRAKES

BRAKE INSTALLATION

1. Brake Mounting Flange

To assure correct brake action, the mounting flange must be square and concentric with the axle spindle. A flange that is not properly installed will contribute to rapid lining wear and improper brake action.

The 13” DEMCO brake is designed to interchange with existing equipment mounting on flanges with (4) holes on 4-13/16” B.C. and a 3-7/8” register diameter. Several manufacturers offer complete axles with flanges attached, or you may choose to install flanges yourself.

Use a flange welding fixture to properly position the flange for welding. Bolt the flange to the welding fixture securely with bolts.

Install the fixture (and flange) onto the spindle and tighten spindle nut. If flange is being installed on a round axle, rotate to secure “wheel cylinder up” location when the axle is installed.

Do not make a continuous weld around the flange. First, tack weld on all four sides between the bolts. Follow this with a full weld up each side of the axle. It is usually not advisable or necessary to weld across the top and bottom of the axle. The bottom of the axle is its most highly stressed area and a weld at this point will weaken the axle. Allow the axle, spindle, and flange to cool before removing welding fixture. See brake drum page for drum face to flange location

2. Installing Brakes

Place the brake against spindle flange. In mounting the brake, be sure the hydraulic wheel cylinder is at the top. Brakes are also marked as “RIGHTS” and “LEFTS”. The brake designated as “LEFT” travels on the driver’s side of the road.

3. Installing Brake Drum

When the brakes have been correctly assembled to the axle flanges, the hub and drum assemblies may be mounted on the axle spindle.

Pack the inside bearing with suitable wheel bearing grease. Force grease through and around the rollers. Place the bearing in the hub and install the grease seal flush with the end of the hub using an arbor press or soft mallet. Remove excess grease.

To avoid damage to bearing seal, lubricate seal seat prior to putting on the hub. Grease, pack and install the outer bearing on spindle. Place flatwasher and spindle nut on spindle. Tighten spindle nut per hub & bearing manufacturer specifications, then install new cotter pin to lock nut, and install dust cap.

Caution: Do not pack hub full of grease. Excessive grease may leak into brake drums causing brake failure.

Wheels may now be mounted on the hubs.

4. Adjusting Brakes

Before removing the jacks, adjust the brakes.

The brake adjustment nut is located through a slot at the bottom of the backing plate. Insert brake tool or screw driver into slotted hole with handle up and bit against the adjusting wheel, pull down on handle and rotate wheel while tightening. When you can no longer rotate wheel in the forward direction, then loosen the large nut on the back side of the brake cluster, located at the 12 o’clock position, one turn, do not take nut completely off, just loosen to allow anchor pin to realign. Take dead blow hammer and tap on brake drum several times around the perimeter, Now retighten the large anchor pin nut, and back off shoe adjuster 10-15 clicks. If there is one spot where the wheel drags just slightly this is acceptable. As soon as the brake linings are burnished (this requires several braking stops) the brakes will then be set right.

ALWAYS ROTATE DRUM IN DIRECTION OF FORWARD ROTATION ONLY.



WARNING: To Prevent Serious Injury or Death

Saltwater, granular fertilizers and other corrosive materials are destructive to metal. To prolong the life of a braking system used under corrosive conditions, we recommend that the actuator be flushed periodically with a high pressure water hose. Be sure to re-grease bearings and oil all moving parts after the unit has dried. At the end of the season, when unit is to be stored, remove the brake drums and clean inside the brakes. Pack wheel bearings before drum is installed.

5. Hydraulic Lines

Use care in forming tubing to avoid sharp bends or kinks. Use double flare steel tubing to assure tight leakproof connections. This must be done by a certified brake shop. Anchor all hydraulic lines at two foot intervals to prevent chafing and vibration. Use hydraulic rubber hose at points of flexing. Anchor hose ends to avoid stress on tubing.

6. Bleeding the System

The first requirement for safe, sure hydraulic braking is the use of quality brake fluid. Use only DOT-3 or DOT-4 brake fluid from a sealed container.

Elevate tongue on trailer 4-6 inches

If pressure bleeding equipment is available, follow the manufacturer's instruction in bleeding the system.

If system must be bled manually, proceed as follows: Fill master cylinder with fluid. Install bleeder hose on first wheel cylinder to

be bled (if tandem axle trailer, bleed rear axle first). Have loose end of hose submerged in brake fluid in glass container to observe bubbling.

By loosening the bleeder screw located in the wheel cylinder one turn, the system is open to the atmosphere through the passage drilled in the screw. Pump actuator with short strokes until fluid in master cylinder reservoir stops bubbling, then pump actuator with long steady strokes. The bleeding operation is completed when bubbles no longer rise to the surface of the fluid in glass container. **Be sure to close bleeder screw securely.**

Repeat bleeding operation at each wheel cylinder. During the bleeding process, replenish the brake fluid, so the level does not fall below the 1/2 full level in the master cylinder reservoir. After bleeding is complete, make sure master cylinder reservoir is filled and filler cap is securely in place.

After the bleeding operation has been completed, apply pressure to the system and check the whole brake system for leaks.

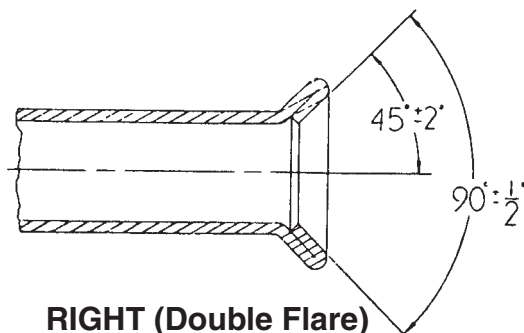
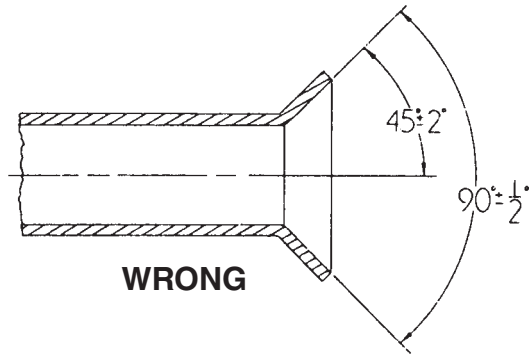

WARNING: To Prevent Serious Injury or Death

FAILURE TO FOLLOW THESE INSTRUCTIONS, OR FAILURE TO PROPERLY MAINTAIN BRAKES AFTER INSTALLATION, CAN RESULT IN LOSS OF BRAKING ACTION. THIS CAN CAUSE PERSONAL INJURY, DEATH OR PROPERTY DAMAGE. ONLY PROFESSIONAL MECHANICS SHOULD INSTALL BRAKE CLUSTERS. HAVE YOUR BRAKES INSPECTED BY A PROFESSIONAL MECHANIC AT LEAST ANNUALLY AFTER INSTALLATION.

WNDT DECAL LAYOUT

WNDT DECAL MAP

DECAL	BALLOON #
4440797-DO NOT EXCEED 25 MPH	1
4440798-INSERT PIN FOR FIELD USE	2
4440799-DO NOT TOW IN TANDEM	3
YELLOW REFLECTOR	4
ORANGE REFLECTOR	5
LIQUID	6
VAPOR	7

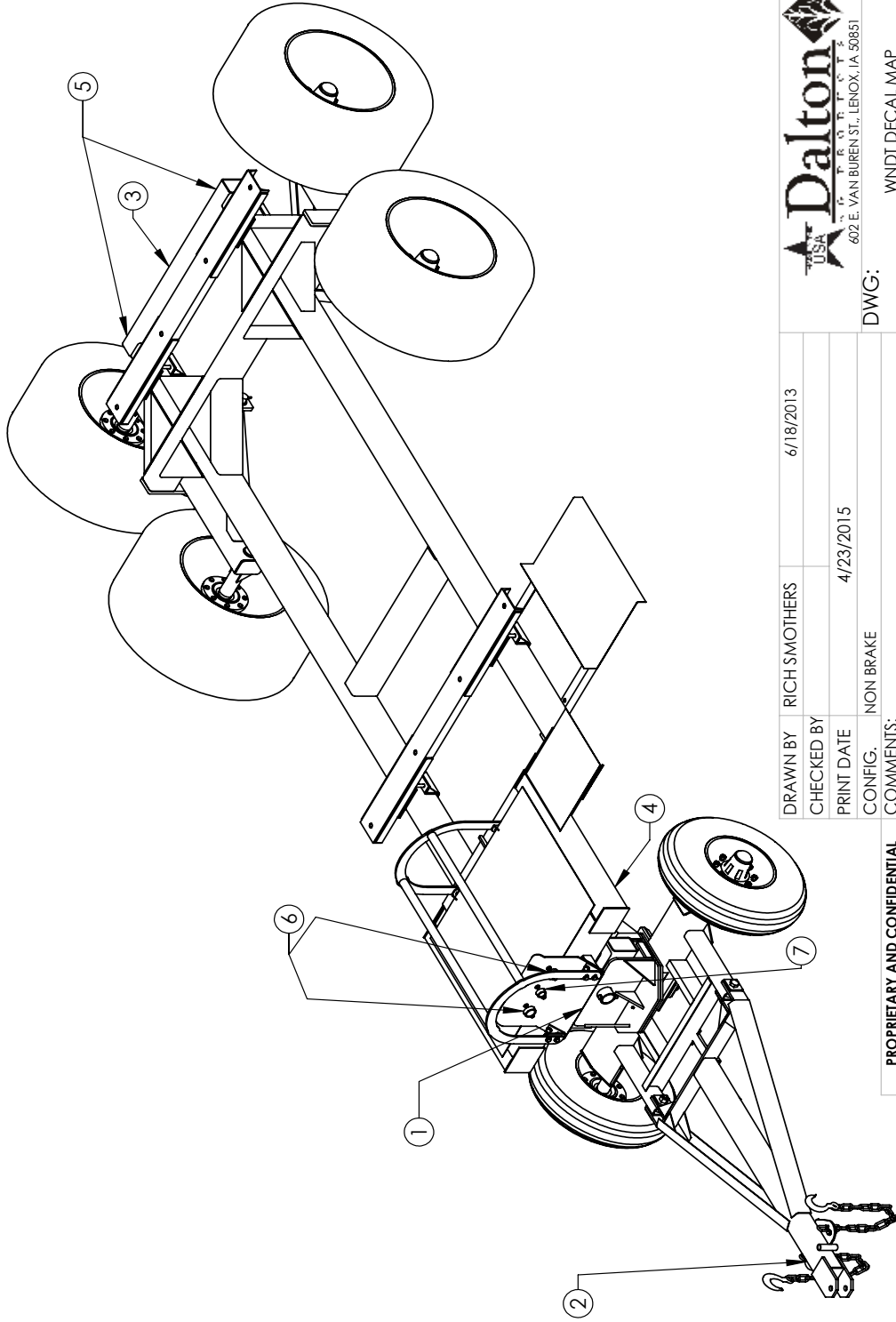

DRAWN BY: RICH SMOTHERS CHECKED BY: PRINT DATE: 4/23/2015 CONFIG: NON BRAKE COMMENTS:	6/18/2013 4/23/2015 NON BRAKE	602 E. VAN BUREN ST., LENOX, IA 50851 DWG:	WNDT DECAL MAP SIZE: A SHEET TITLE: Sheet1 REV: A
PROPRIETARY AND CONFIDENTIAL THE INFORMATION CONTAINED IN THIS DRAWING IS THE SOLE PROPERTY OF DALTON A.G. ANY REPRODUCTION IN PART OR AS A WHOLE WITHOUT THE WRITTEN PERMISSION OF DALTON A.G IS PROHIBITED.		SCALE: 1:30 SHEET 1 OF 1	

PARTS ORDERING PROCEDURE

Your Dalton Ag dealer is interested in your new fertilizer application equipment and has the desire to help you get the most value from it. Through the help of this manual, you will find you can do some of the regular maintenance yourself. For parts and service, contact the Dalton Ag Dealership from which you purchased your fertilizer application equipment or your local Dalton Ag dealer.

When replacement parts are required, consult the applicable illustration and parts list to obtain the correct part name and number. When requesting a replacement part, always include the following information:

1. Complete Part Number
2. Description
3. Quantity Required
4. Machine and Model Number
5. Machine Serial Number - located on the topside of the frame near hitch
6. Provide complete name and address for where and how parts are to be shipped.

NOTE: Right and left hand parts and sides of the units are determined by standing at the rear and facing in the direction of forward travel.

EQUIPMENT MODEL: _____

EQUIPMENT SERIAL NO.: _____

DATE OF PURCHASE: _____

NAME OF DEALER: _____

DEALER'S PHONE NUMBER: _____

Thank you for your business!



www.daltonag.com

602 E. VAN BUREN | LENOX, IOWA 50851 | 800-342-7498